



ARTSCAPES. IKA, WINTER Semester 2018/2019

## **THE DUCKPIT**

**The duckpit project is a critical interface for a collaborative reaction on a borderline of virtual and „real“ – an architectural speculative device for re[dis]covering economical and social glitches in political propaganda.**



**The future artspace I envision, isn't a place to be for high society, collectors or art-scene hunters, it's a place of actuality, of contemporary becoming, a pit that is pointed into today's world. Where art is acting as an instrument for guerilla communication, where toospace rather fits than gallery, a data center as a weapon for society.**

**My project derives from a digital artefact of the so called spanish house in the Savamala district in Belgrade , which is currently getting transformed into a huge real estate development project called Belgrade Waterfront. Mohamed Alabbar, board member of the Abu Dhabi based Eagle Hills Company was willing to invest more than 3 billion dollars in Belgrade.**

**Those EUR 3.5 billion were the only reason the project was proclaimed of national significance and given the possibility to proceed on a fast lane, without a public offer, without a competition, and thus gained the ability to change the urban plans, install new laws, and expropriate. Not to mention that people got killed through the expropriation for this copy paste architecture. After two years of announcements those wishful EUR 3.5 billion were signed in the form of EUR 150 million and a loan. The Prime minister 'called in sick' and was absent during the signing.**

**What if information merely circles around in its own parallel world? What's to be done if the street demonstration becomes just a part of the spectacle? In the age of realtime global events we should make the metaphor to define art as an antenna of the human race which shows its passive and responsive nature. Giving a focus on digital art this project tries to tackle the myth of transparency, that a technology can disappear completely and put the viewer or user in touch with reality.**

**How software interfaces and alternative standards can be installed in society? My idea may take the shape of a triggered virus or a manipulative infrastructure, or just an immunization program such as repression and neglect. If I say digital art, I don't understand an interface or application as a series of static screens, but rather as a process of give and take between computer and user or art and architecture, so that a if-then scenario is created.**

**A digital artifact can be designed to unfold in multiple ways. It can help us see how to design for multiplicity, because such art adapts itself to the user rather than forcing the user to follow a rigid script. It oscillates between being transparent and reflective, it is ubiquitous.**

**All new media art objects placed in my gallery, play with the surreal edge between physical and virtual reality, between history and future related to the Belgrade Waterfront project. There is always a tension between the two worlds: the world depicted by any digital application and the physical world in which the user must function to survive.**

:

**Duck Pit is a creation of compelling experience, an interaction between art and the user (consumer) through the technology is what gives the experience its meaning. Its also contextual, in the sense that the design must both respond and shape the contexts (physical, political and cultural) in which they function.**











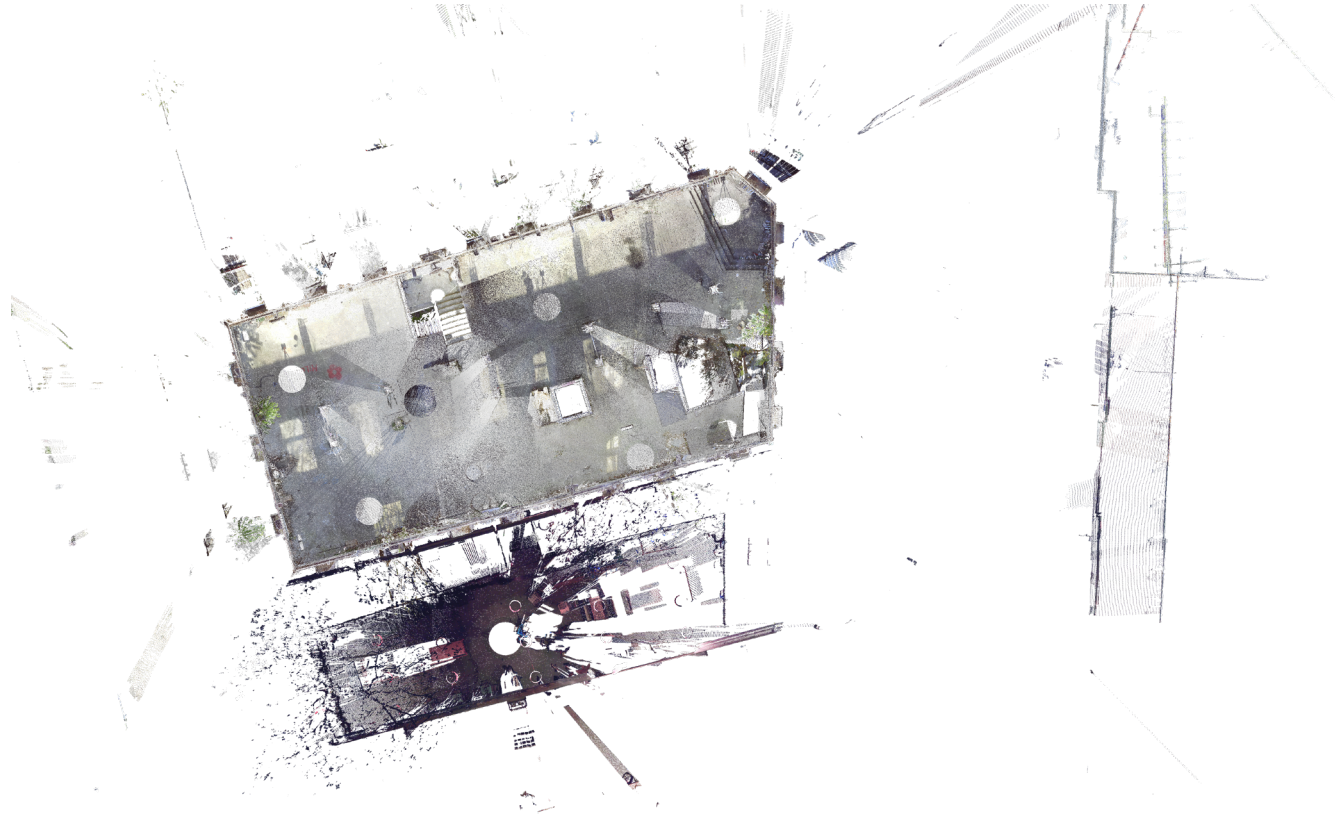



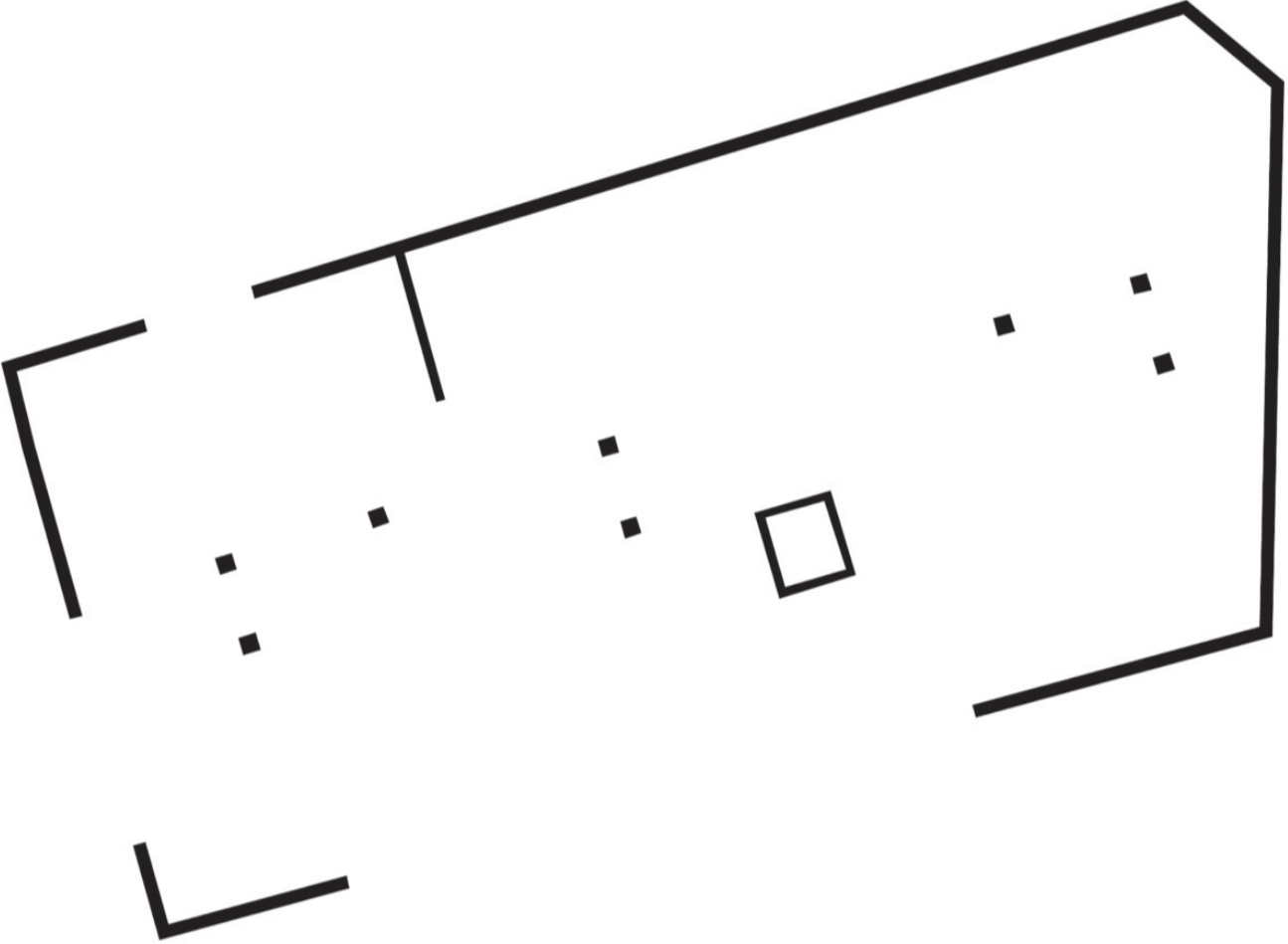

fig\_3



**The BW [Belgrade Waterfront] is a giant housing and commerce implant to the heart of the city, that is officially considered to be a revitalizing development and a promotion of Serbia to the world, while behind a „false facade“ brought up by highly ubiquitous social media promotion lies an ambiguous picture of the Belgrade future and a conflict of interests.**





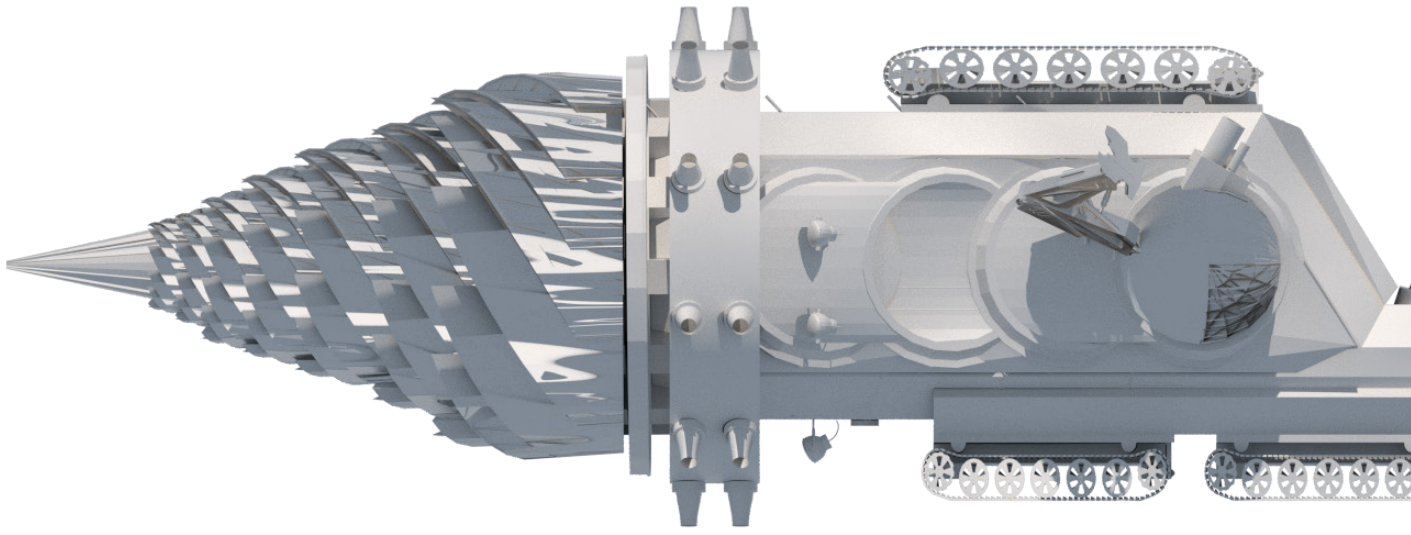

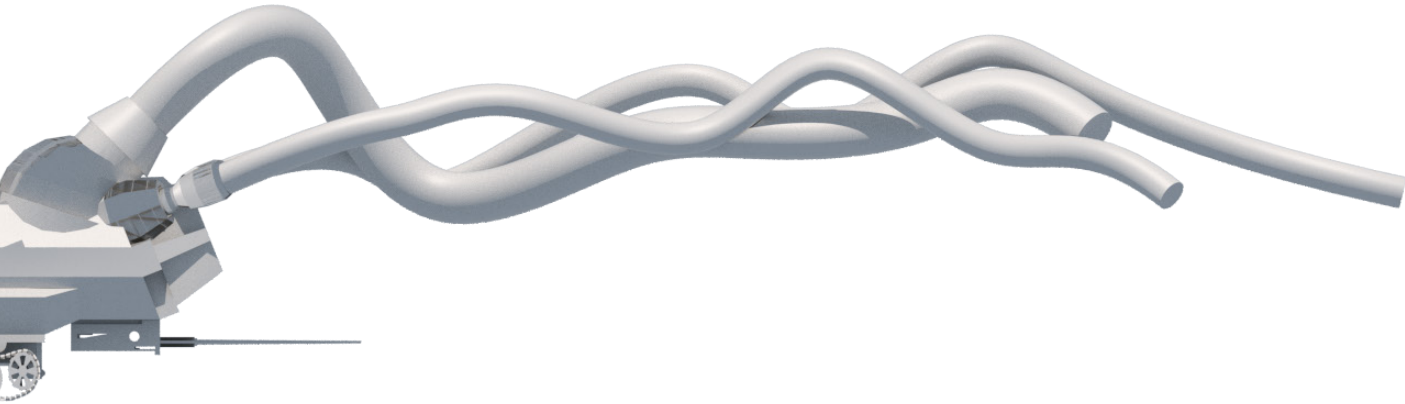



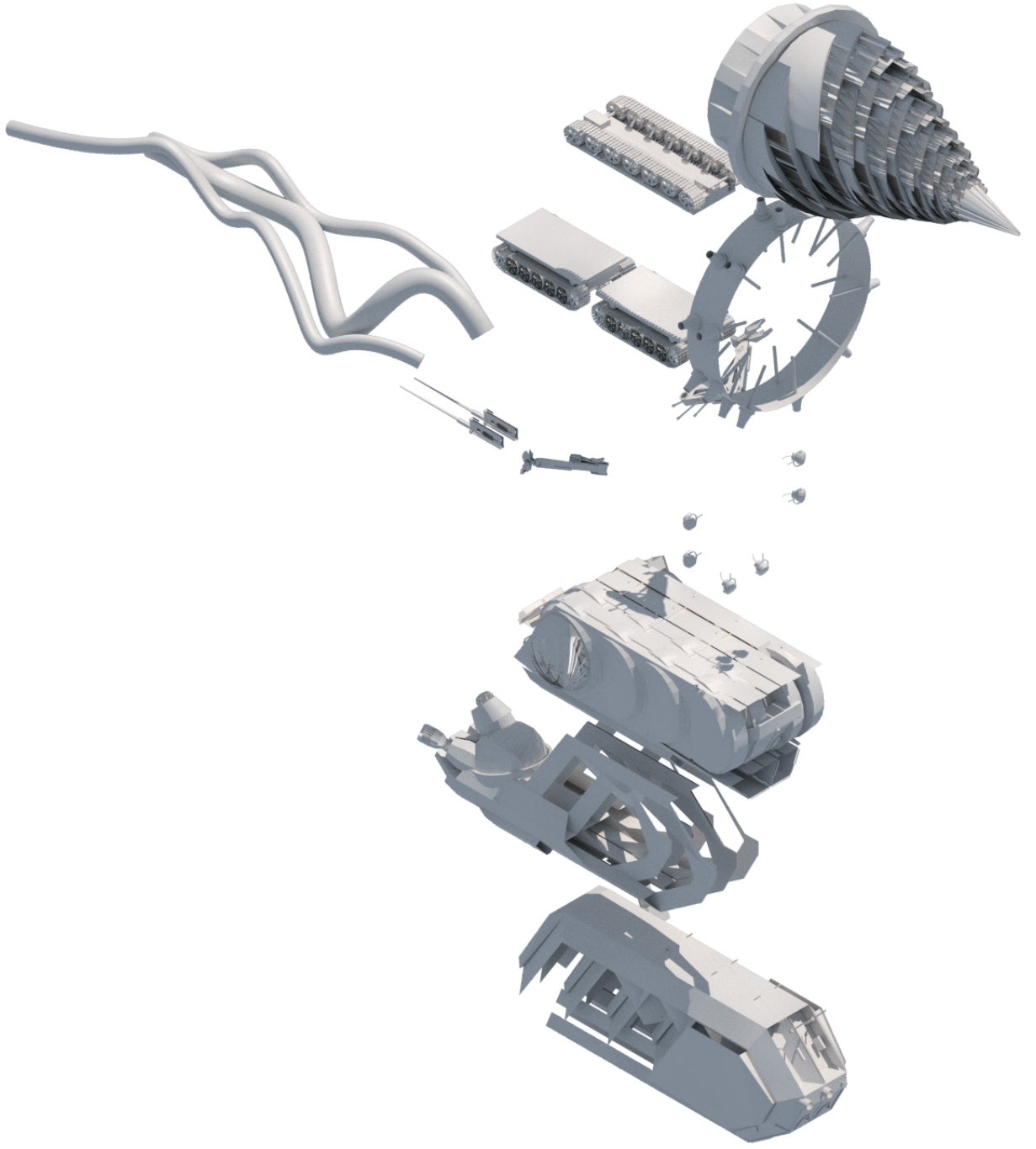

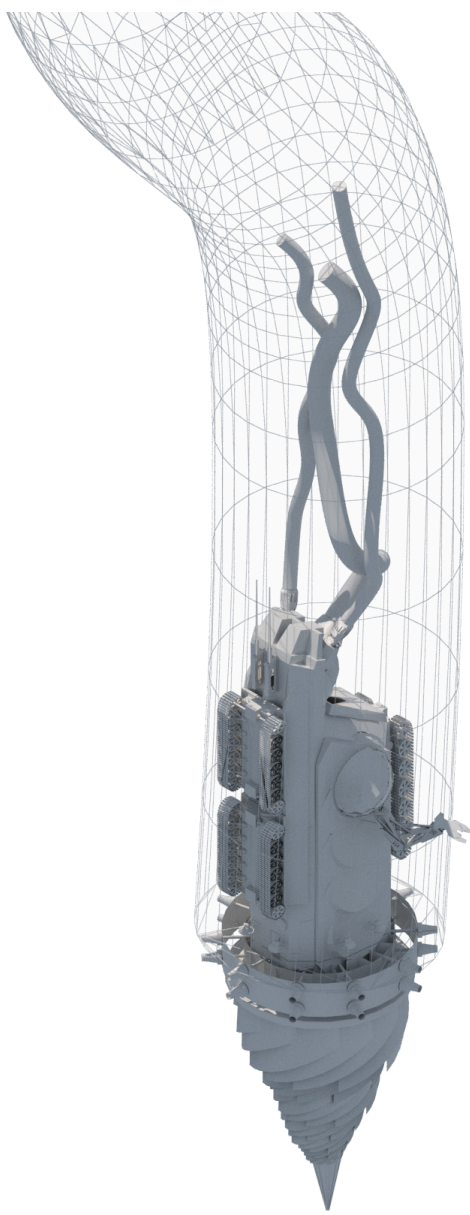

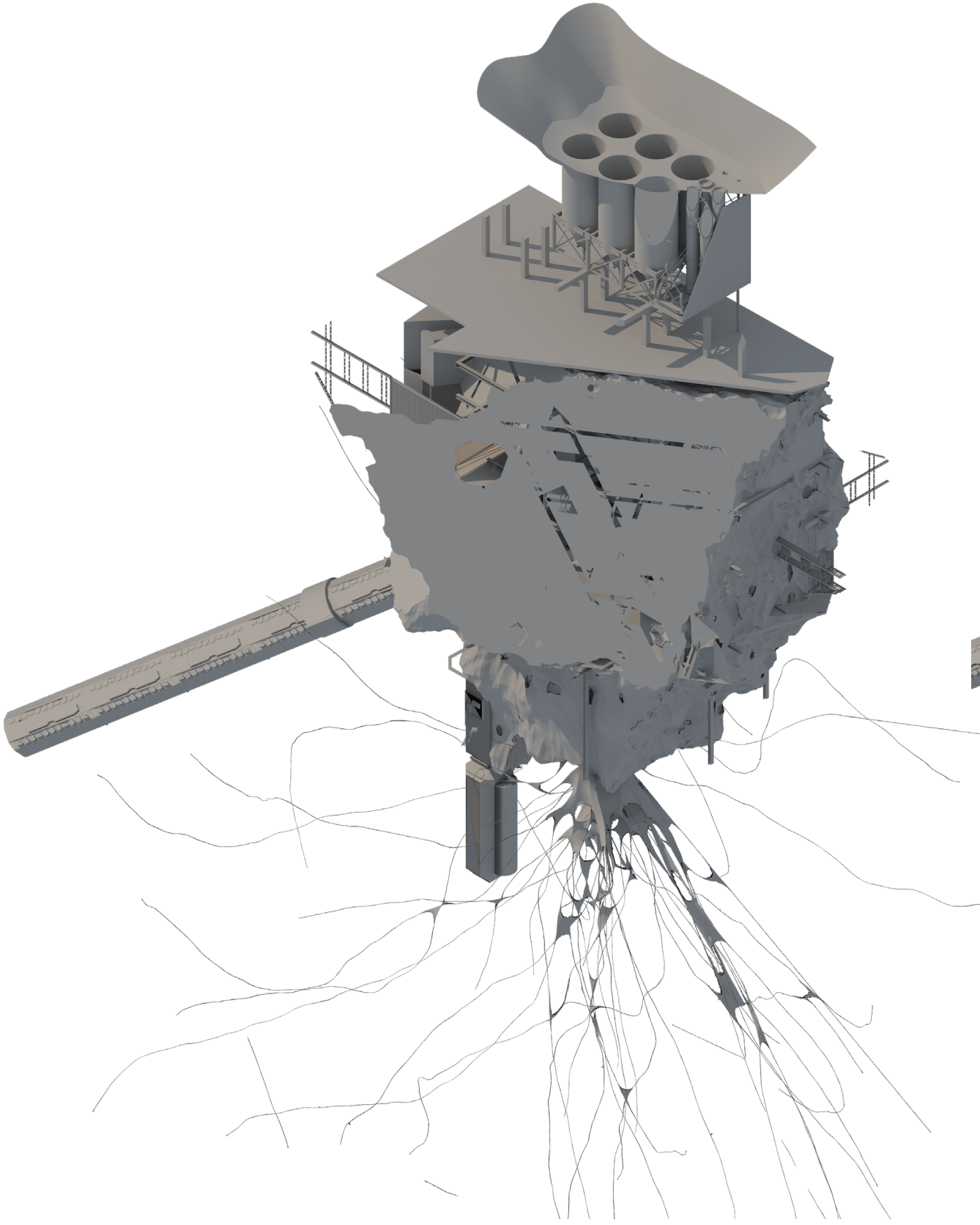



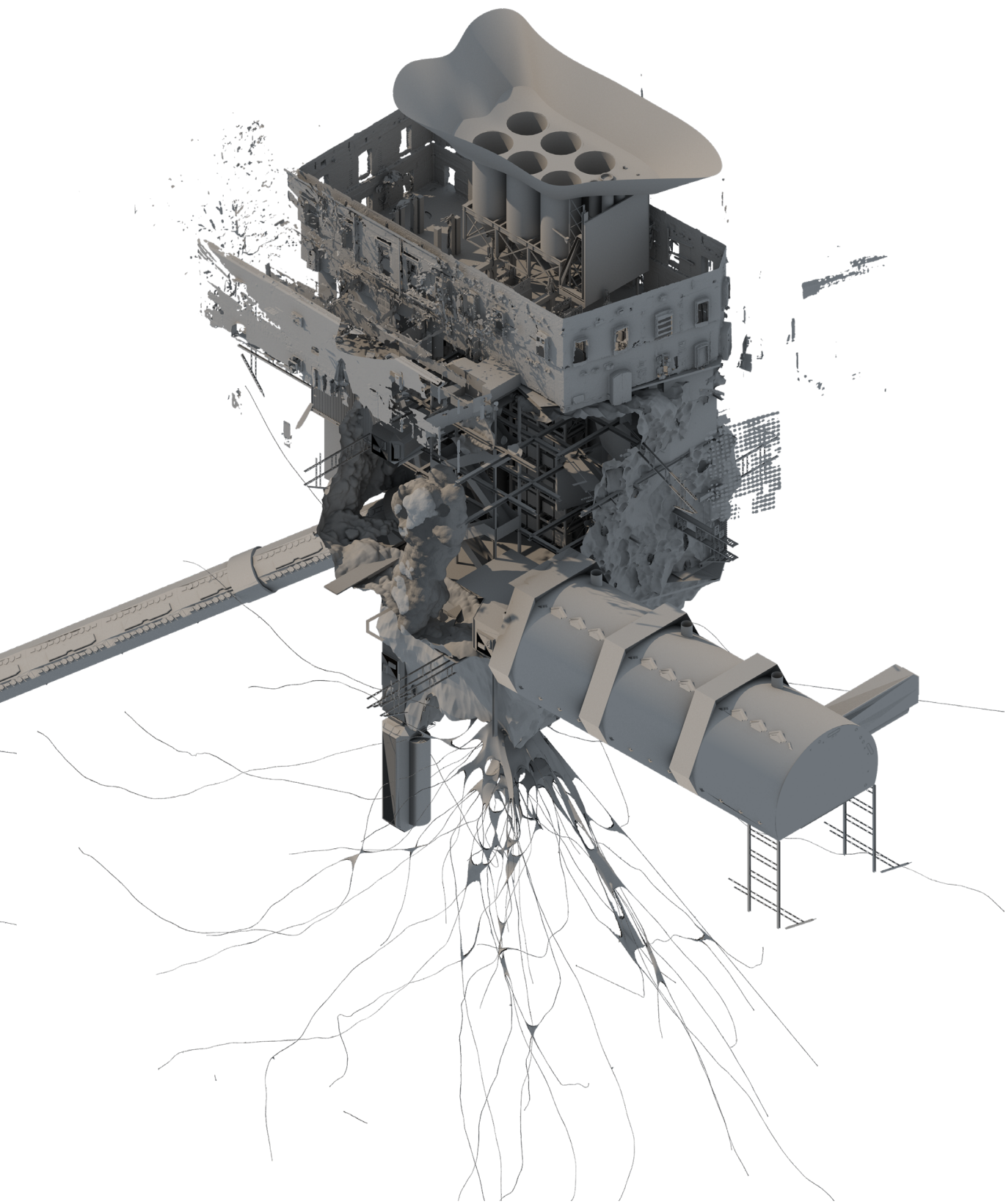

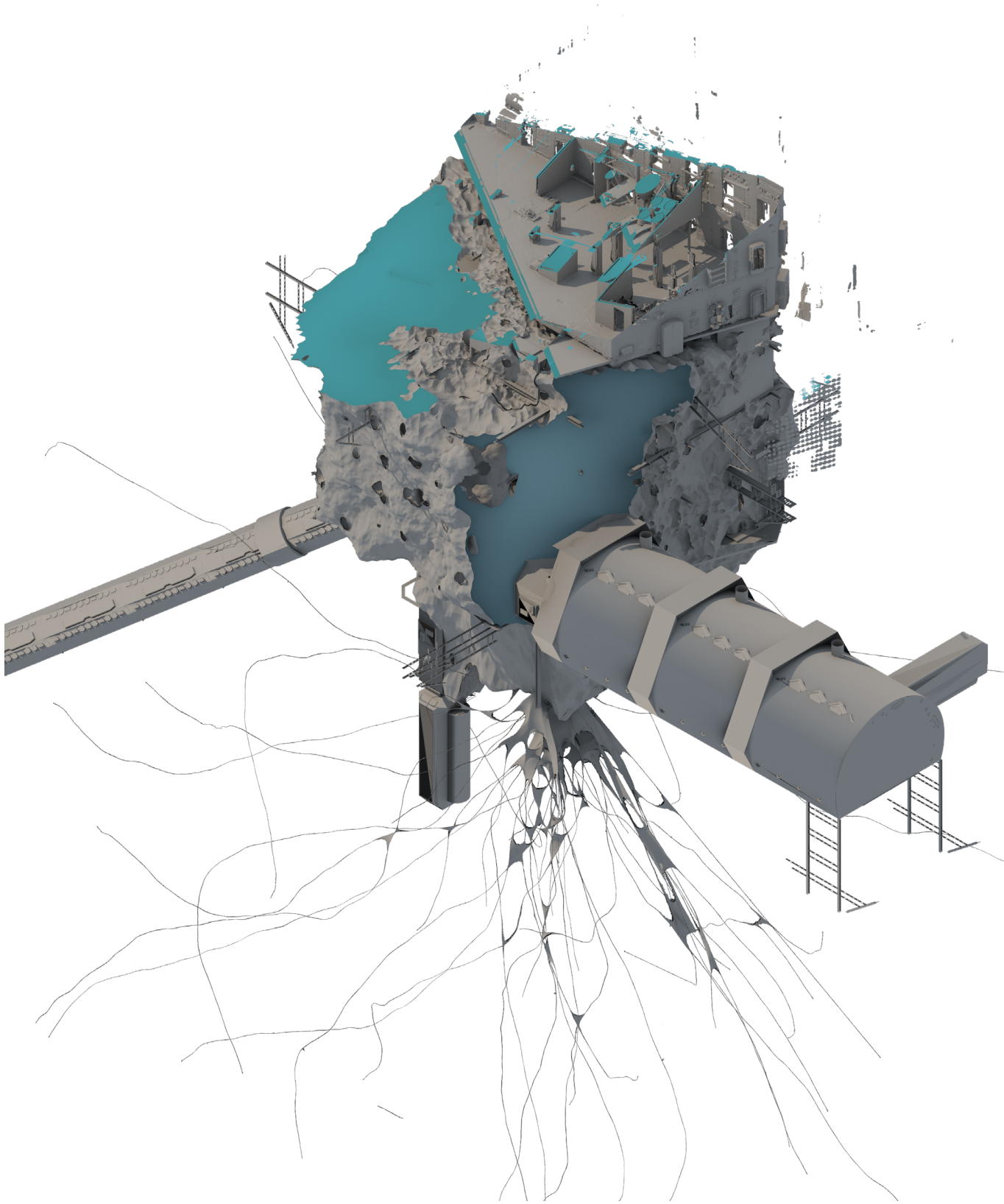

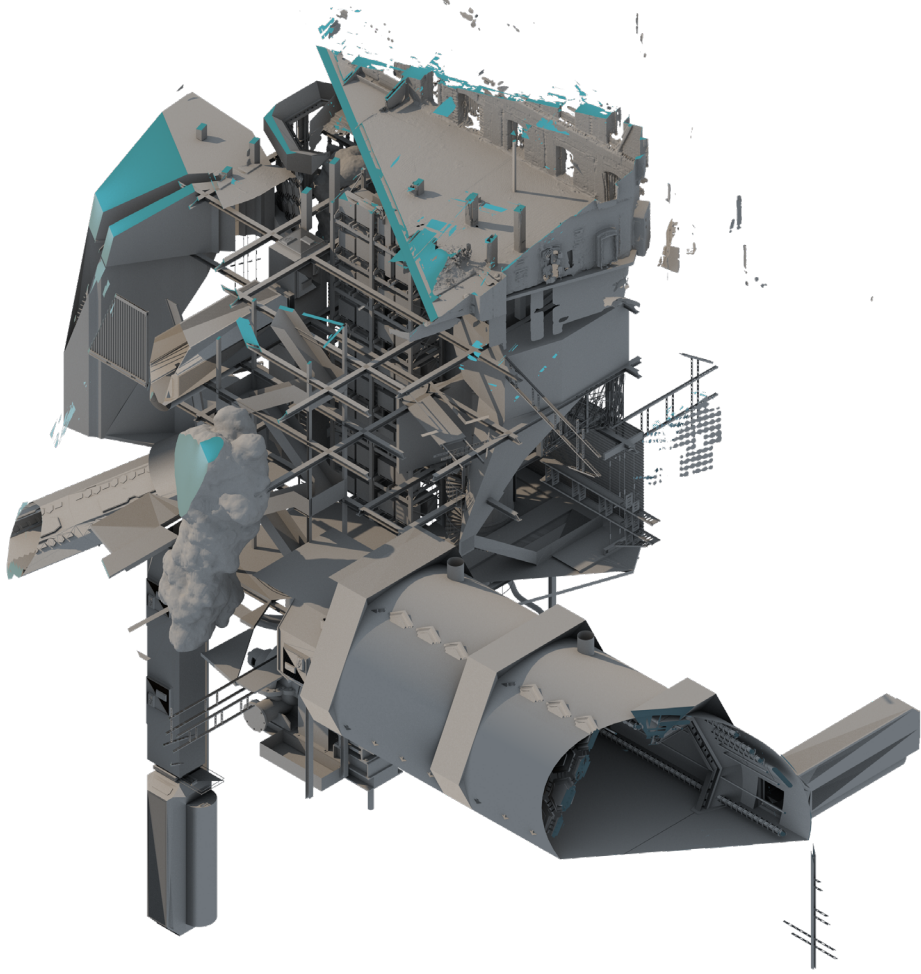

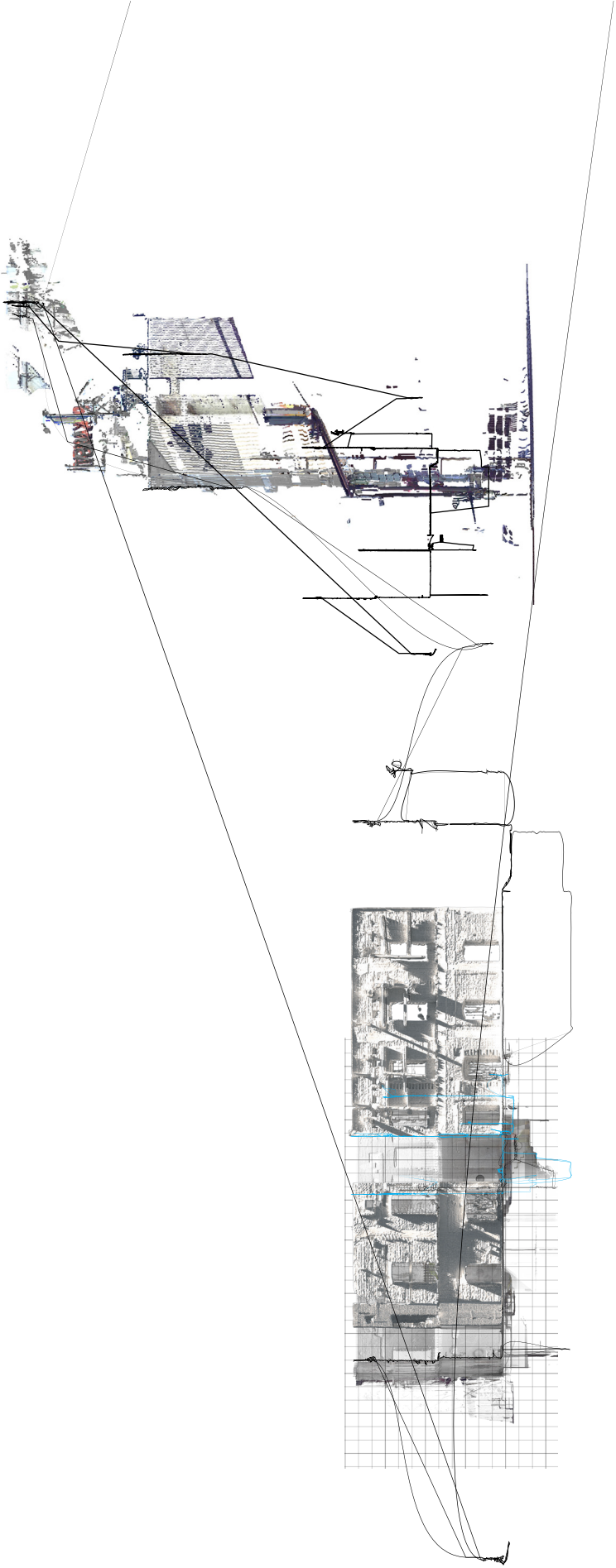





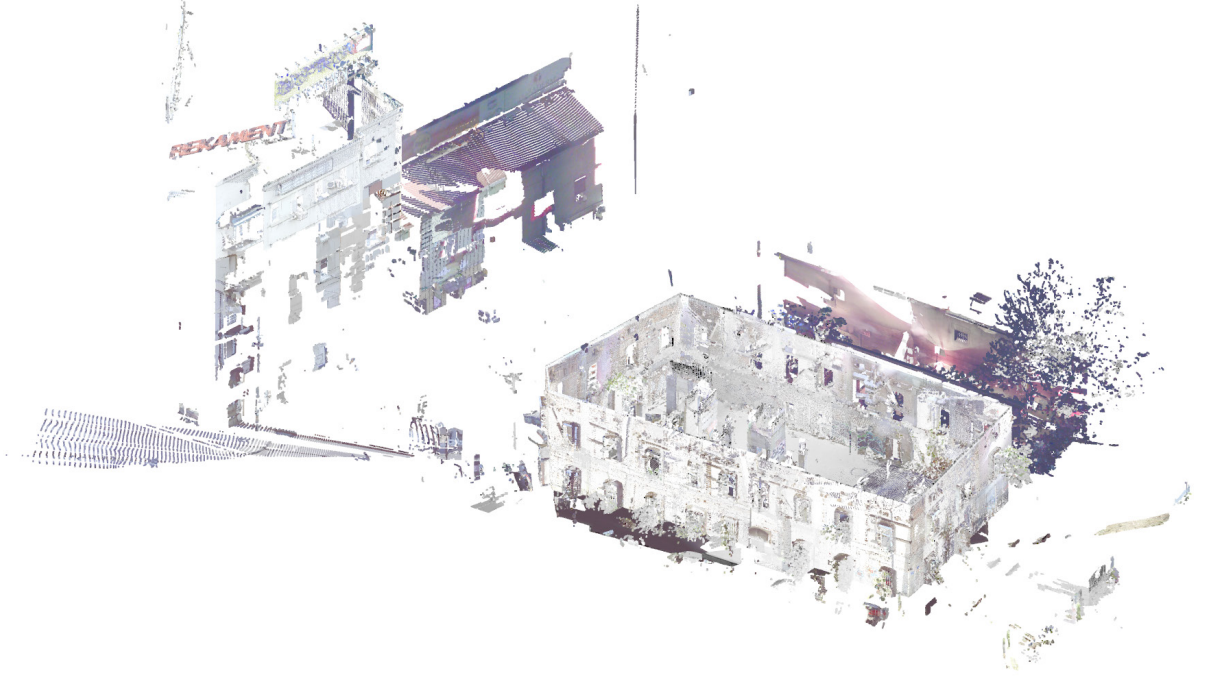

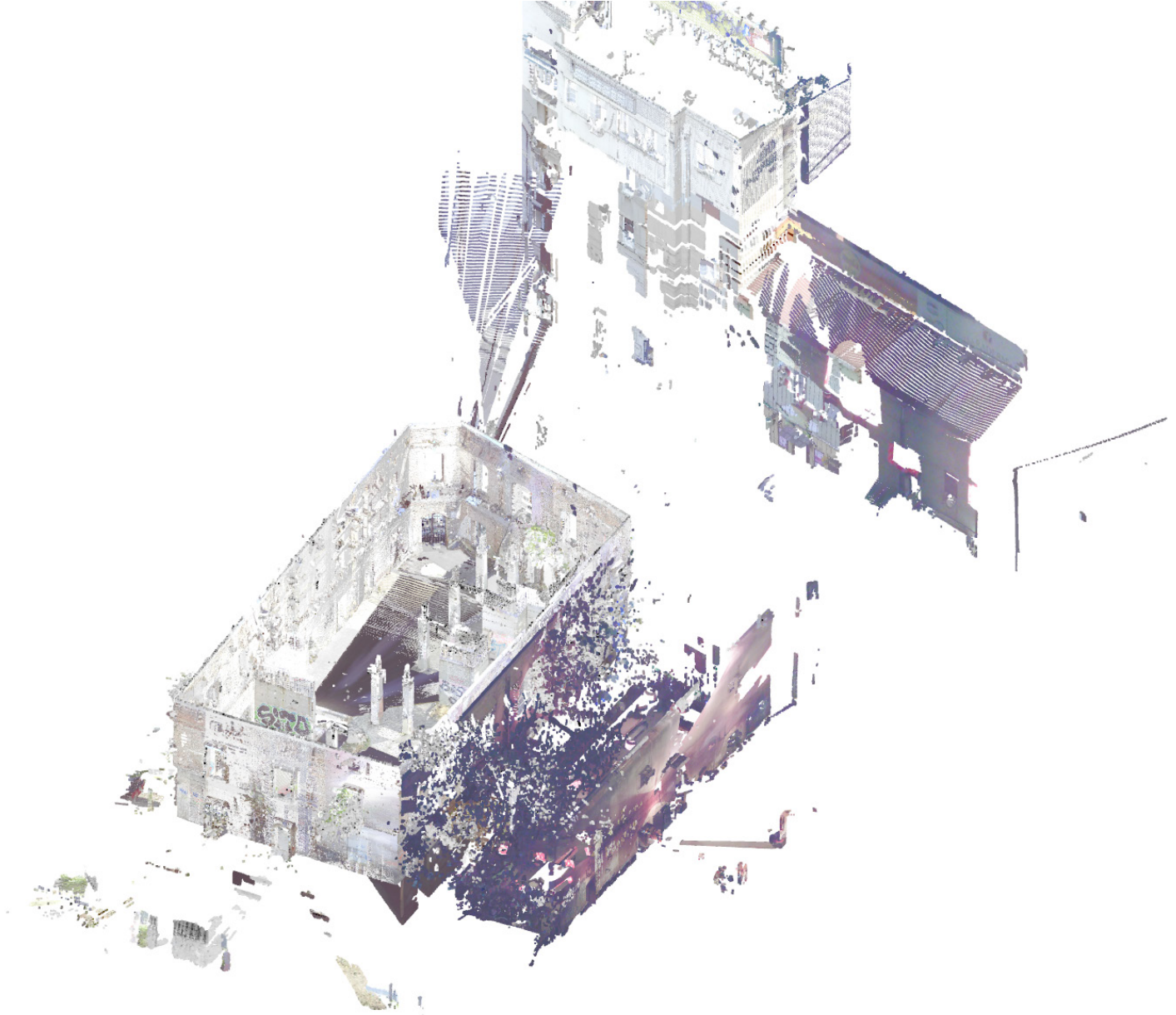

fig\_1

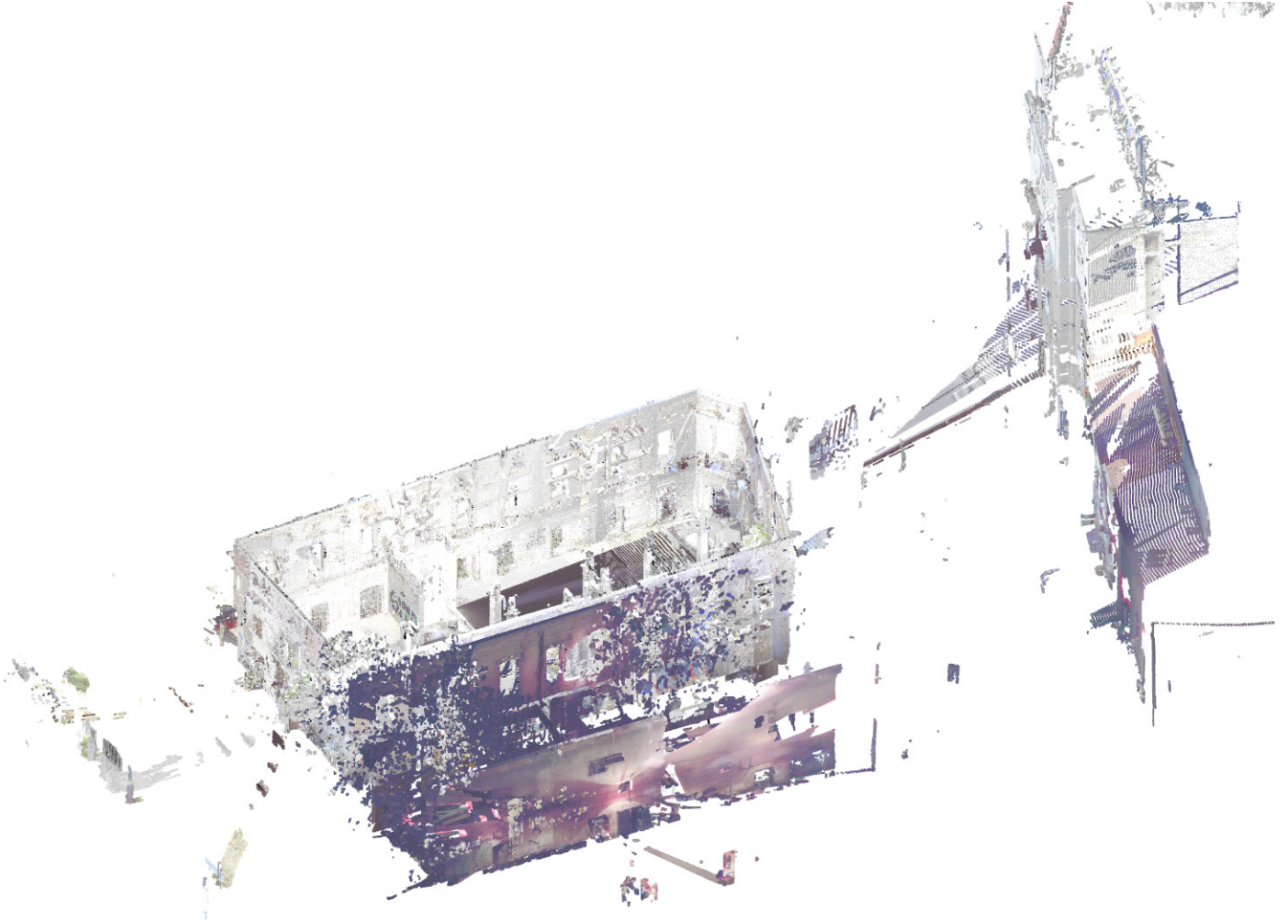





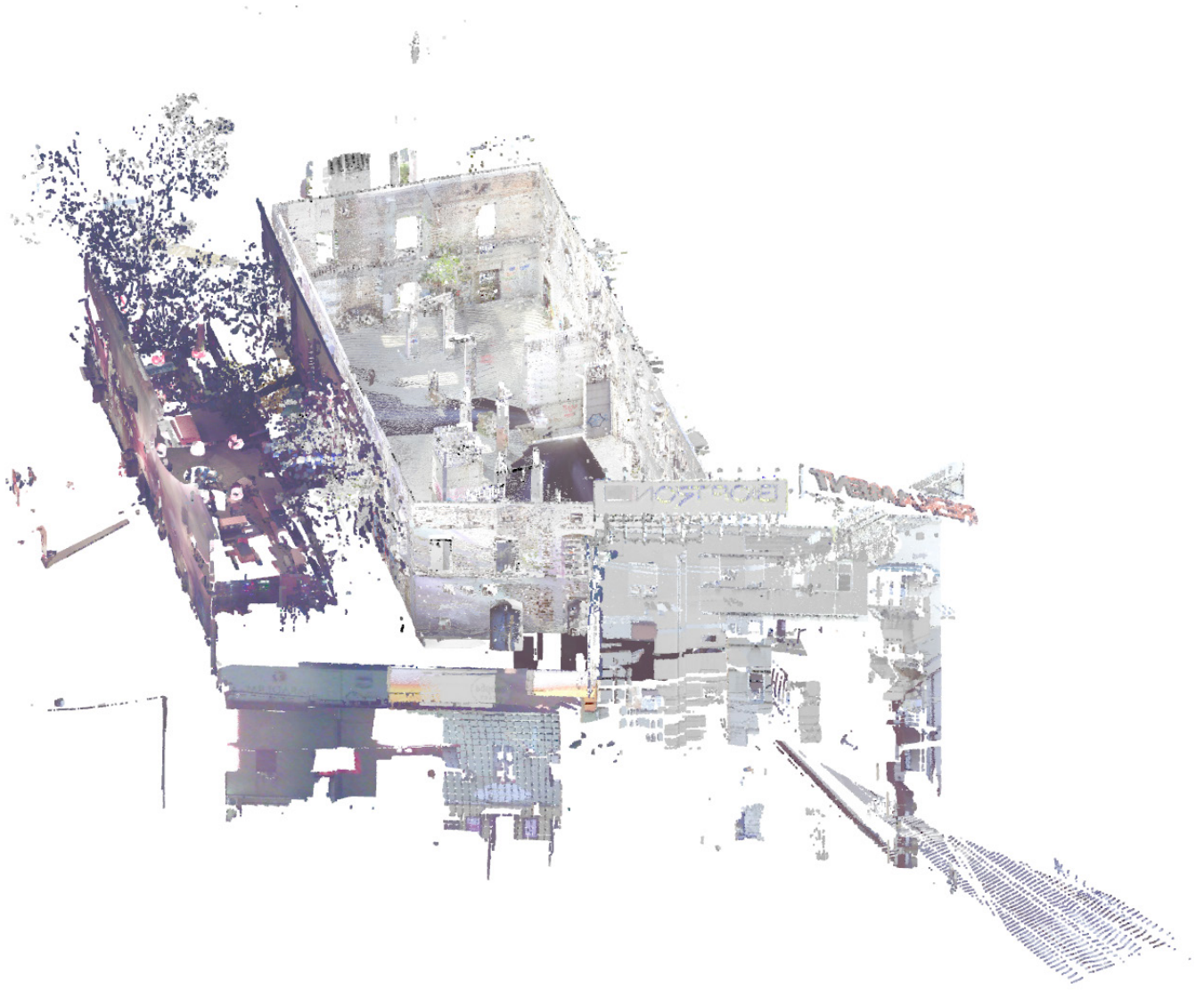

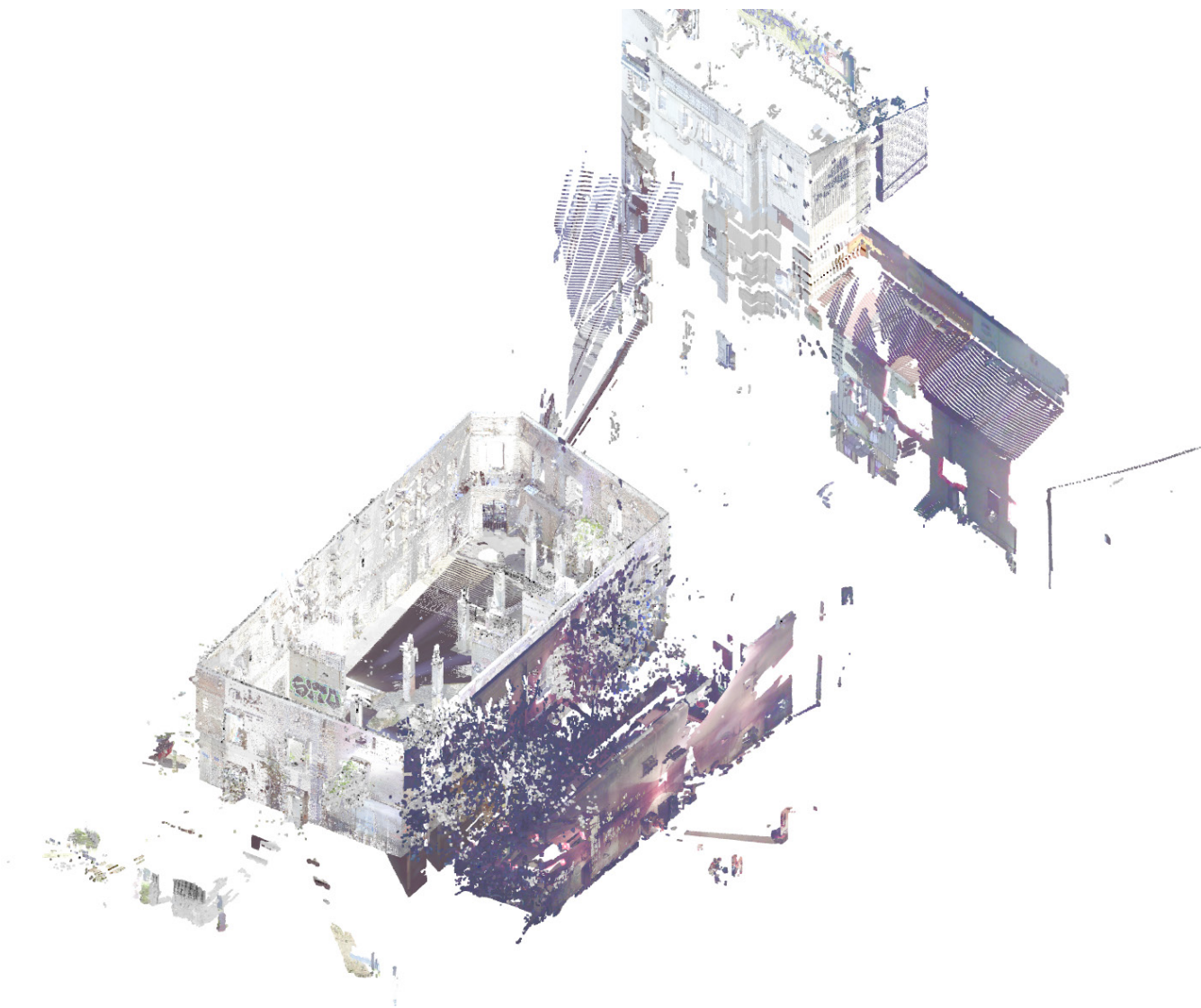





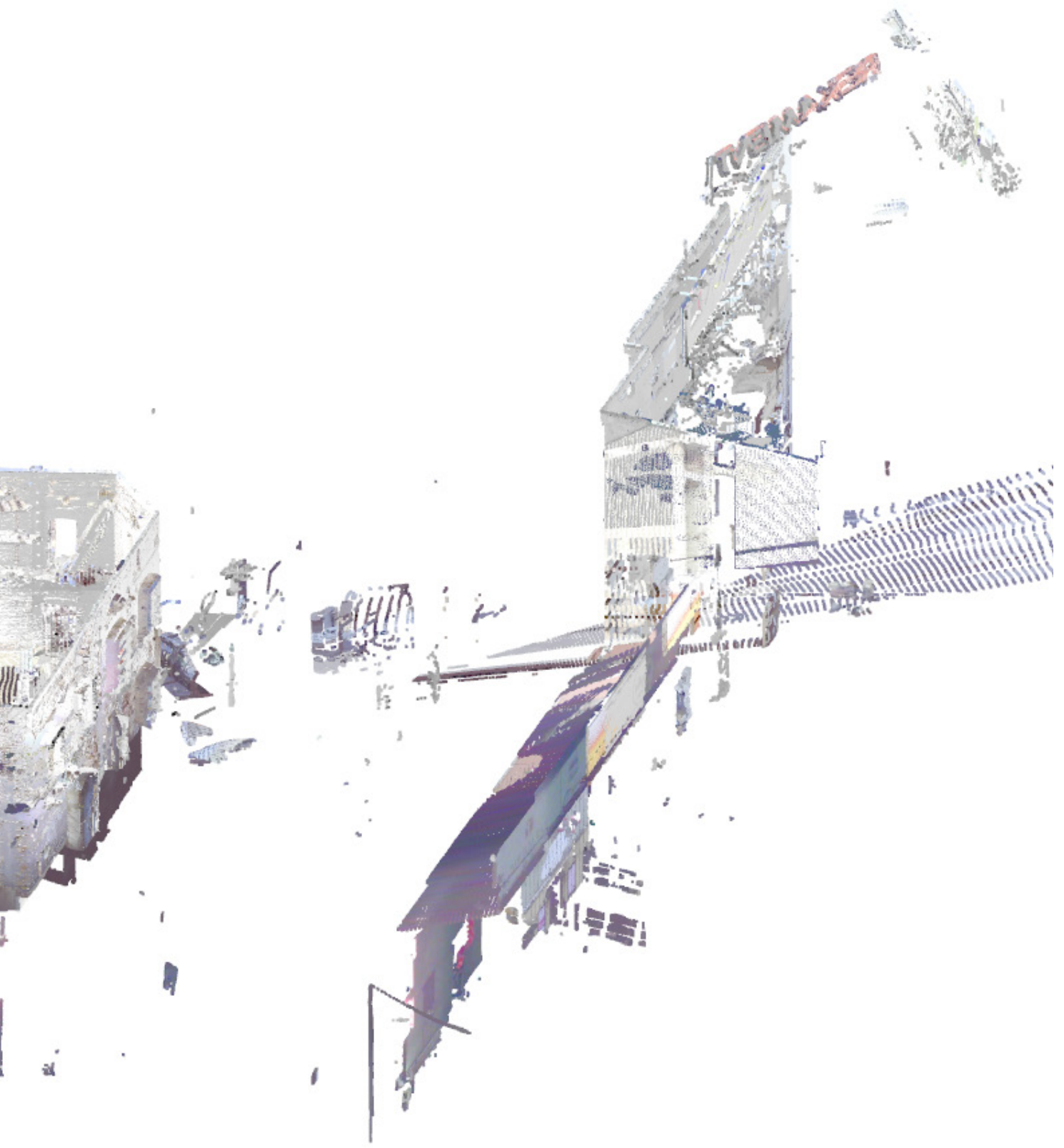





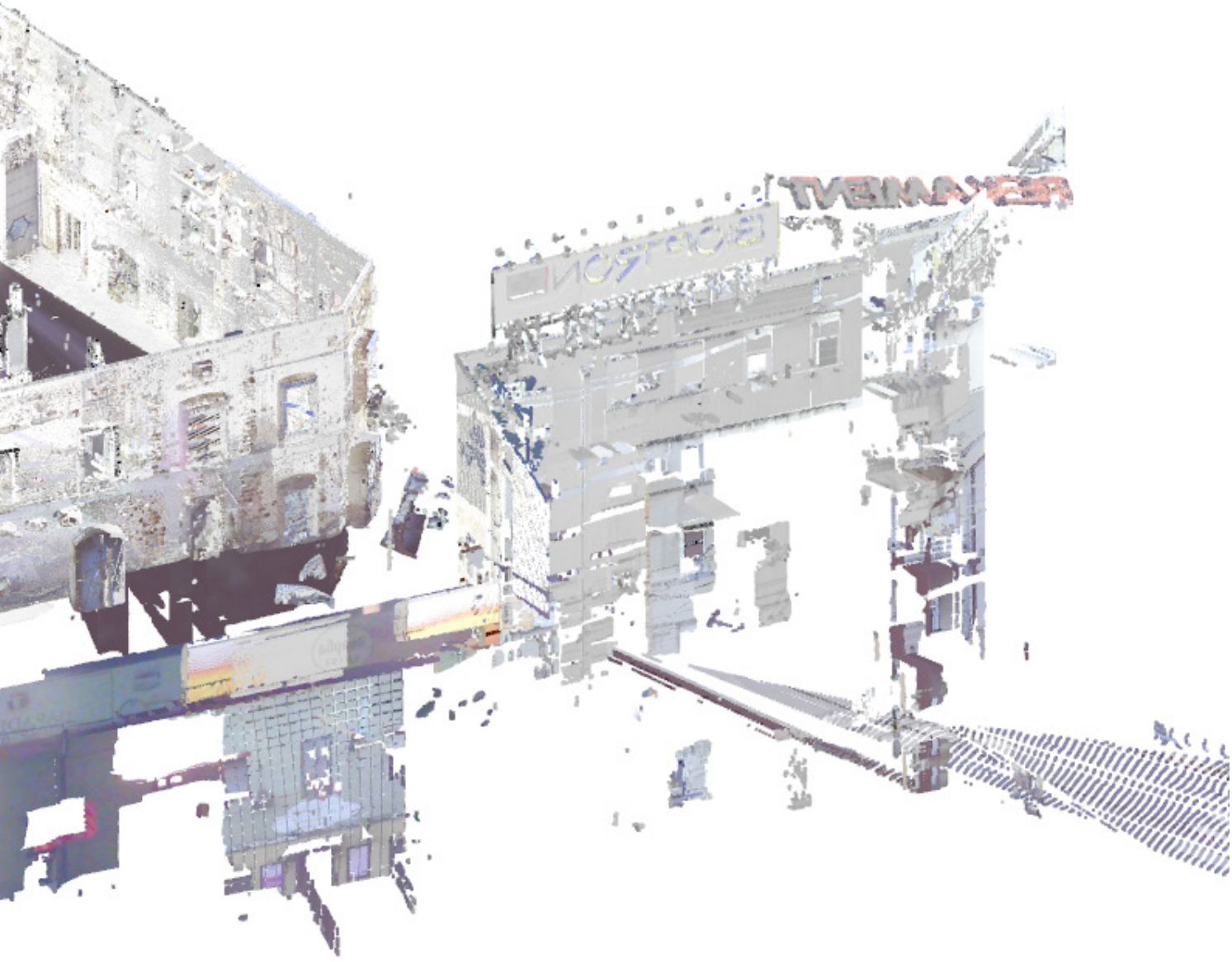

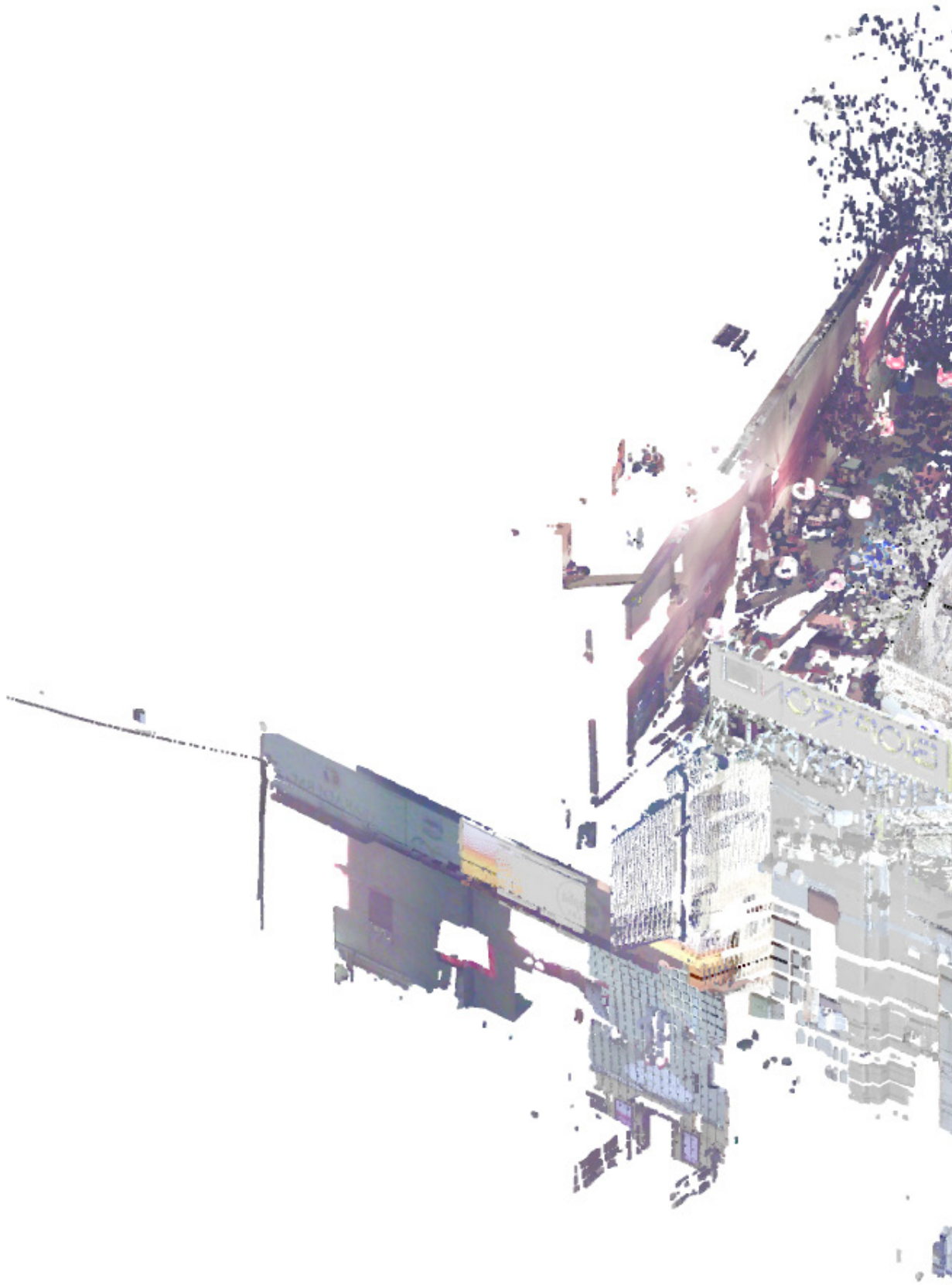



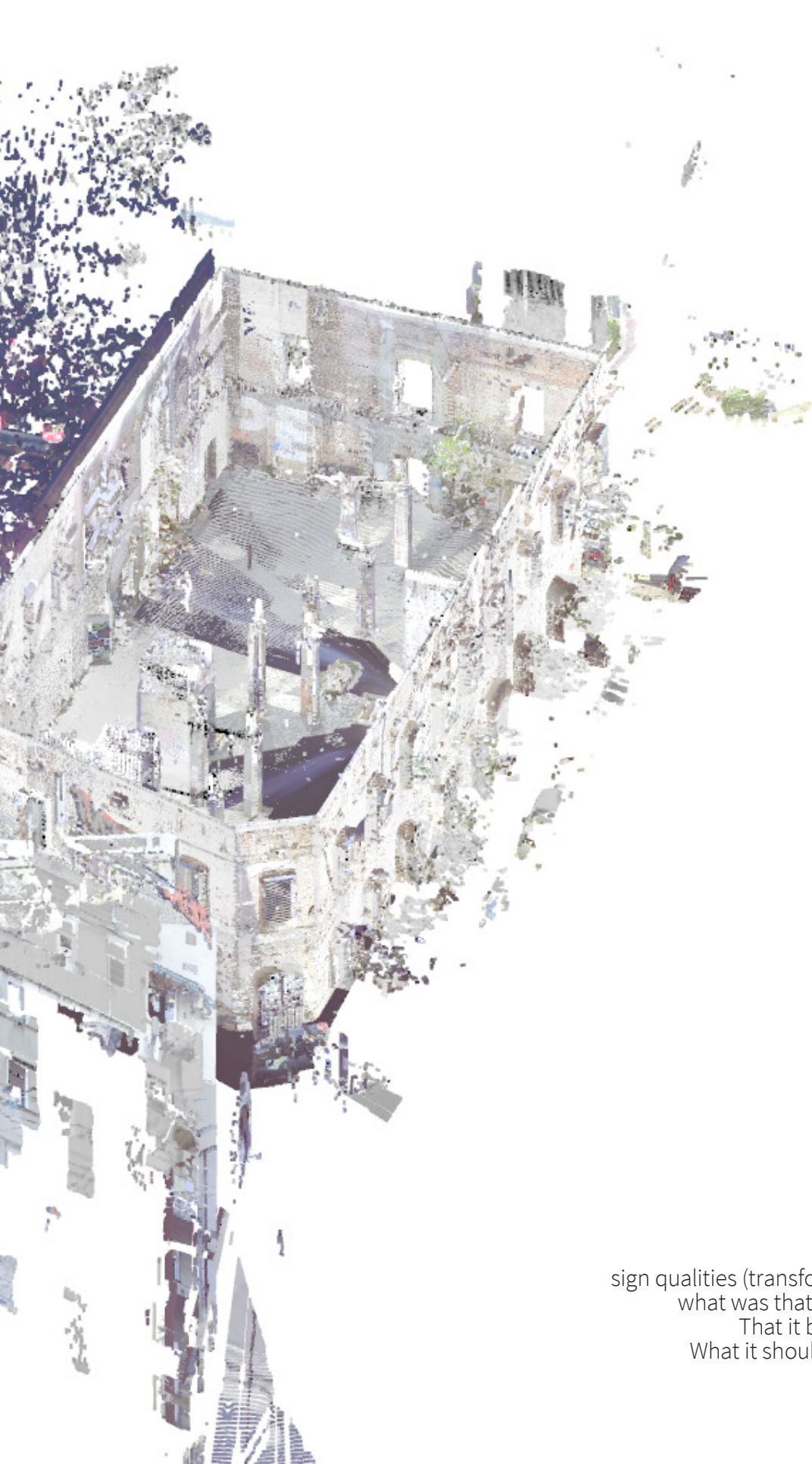

sign qualities (transformations) as physical  
what was that house before?  
That it became?  
What it should have been?

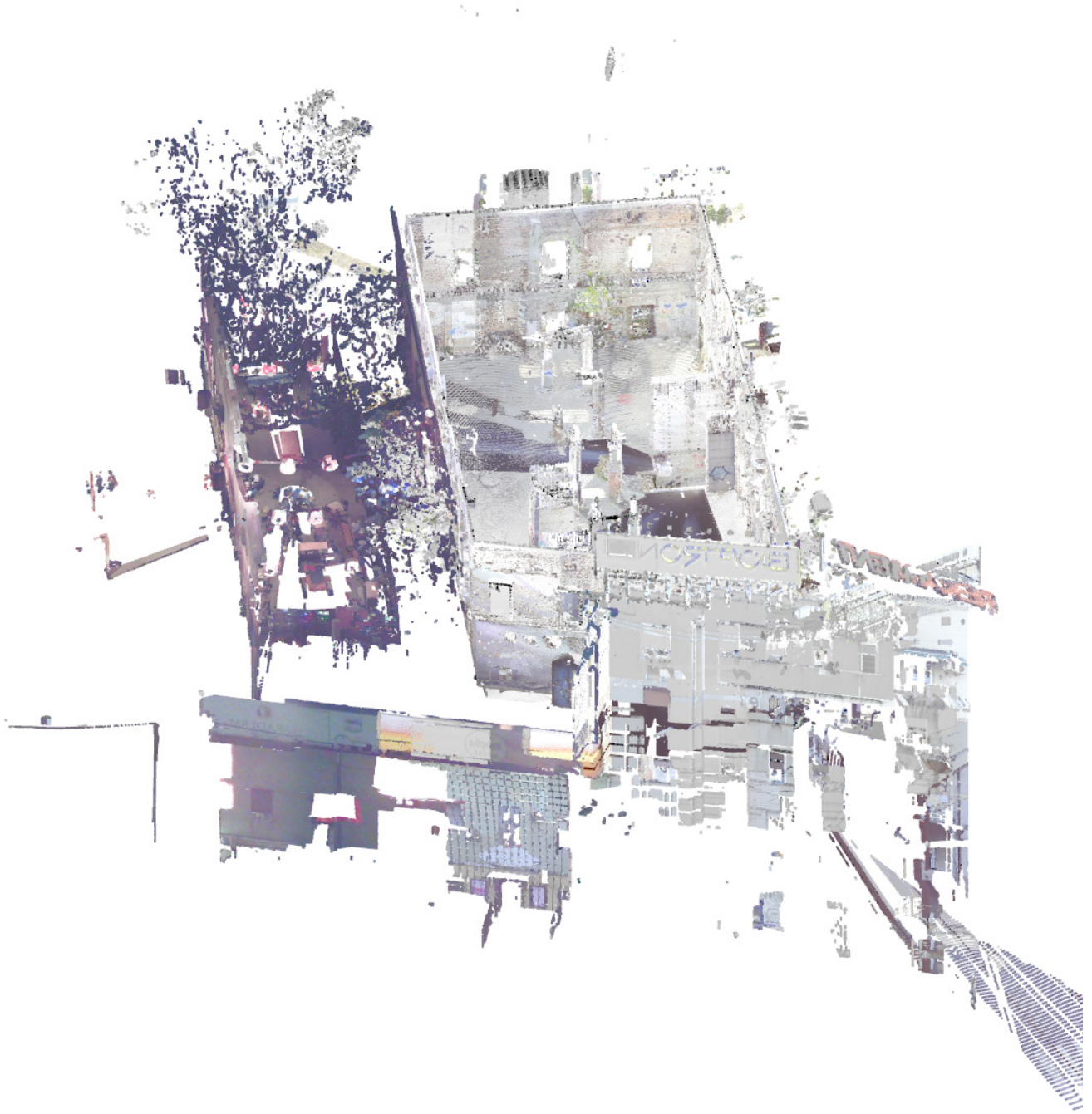







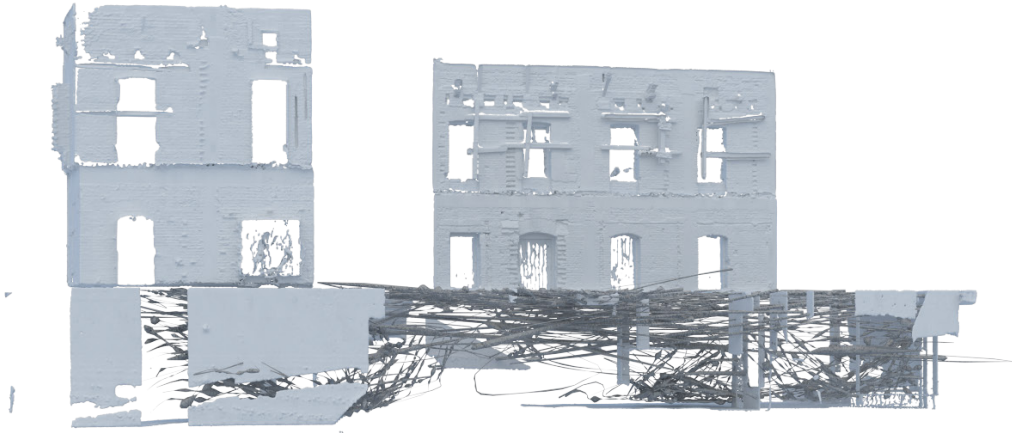



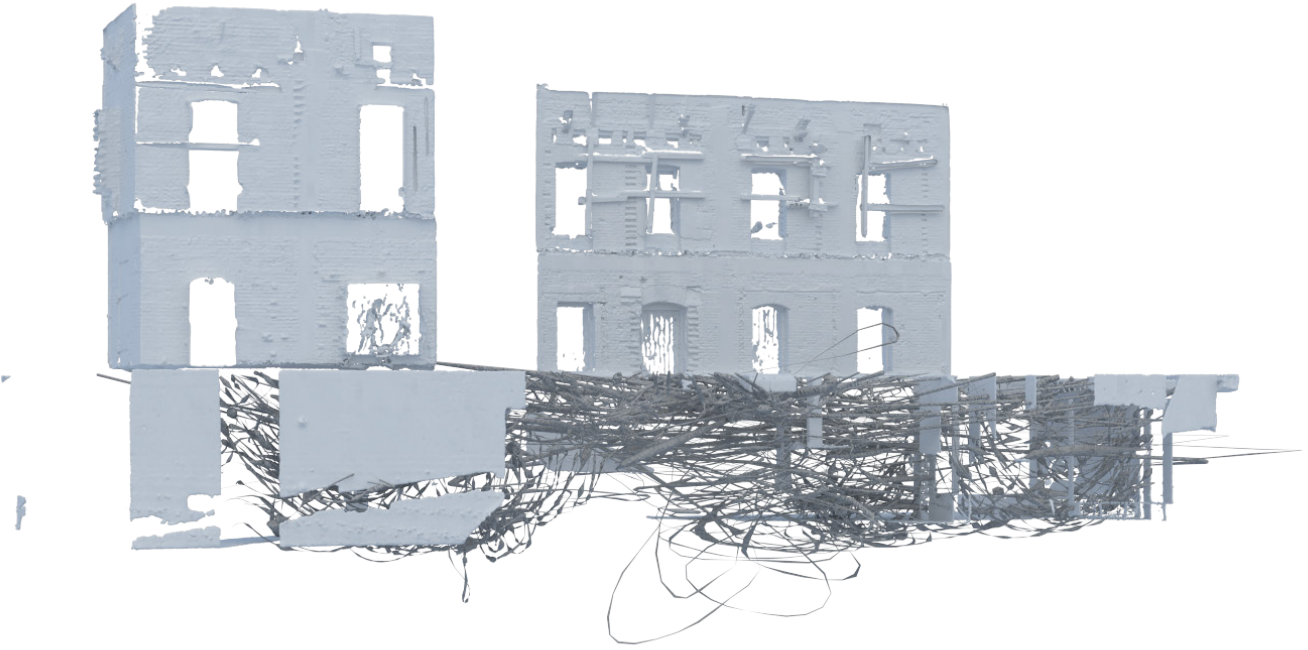

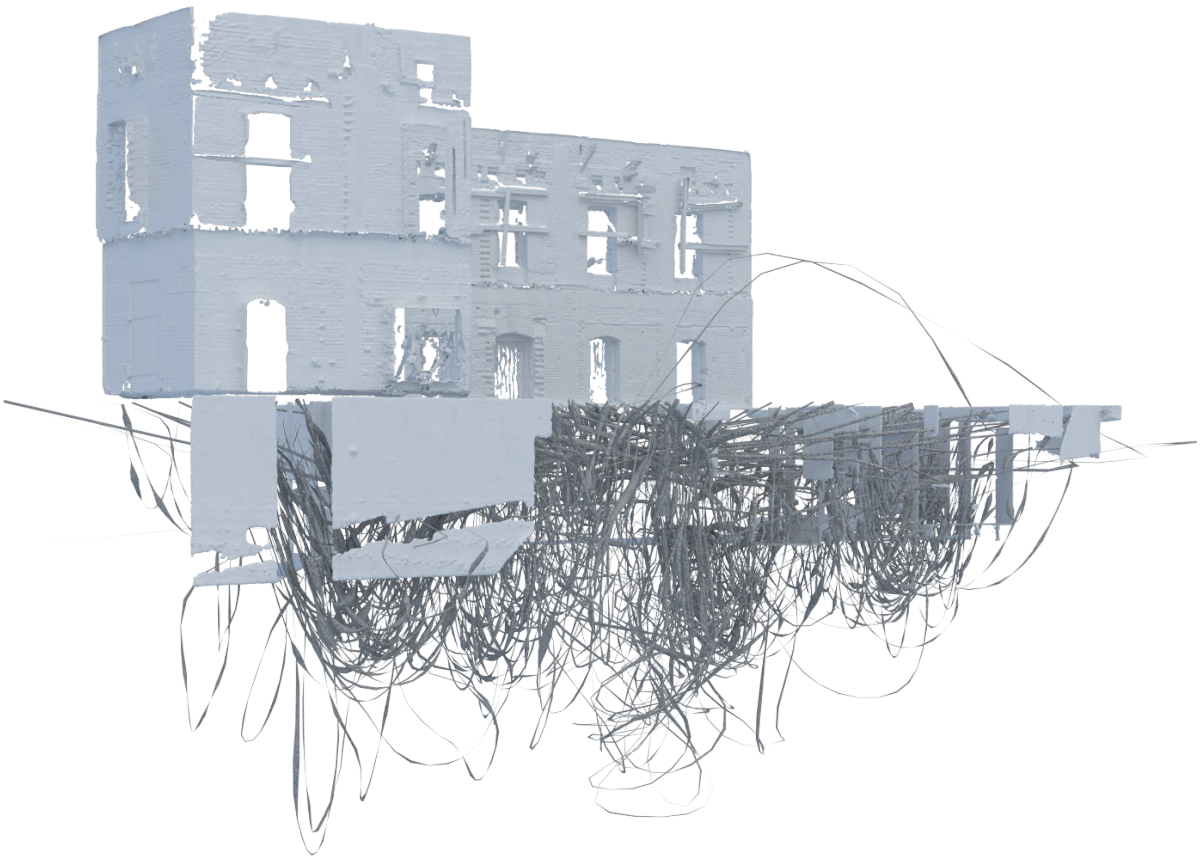

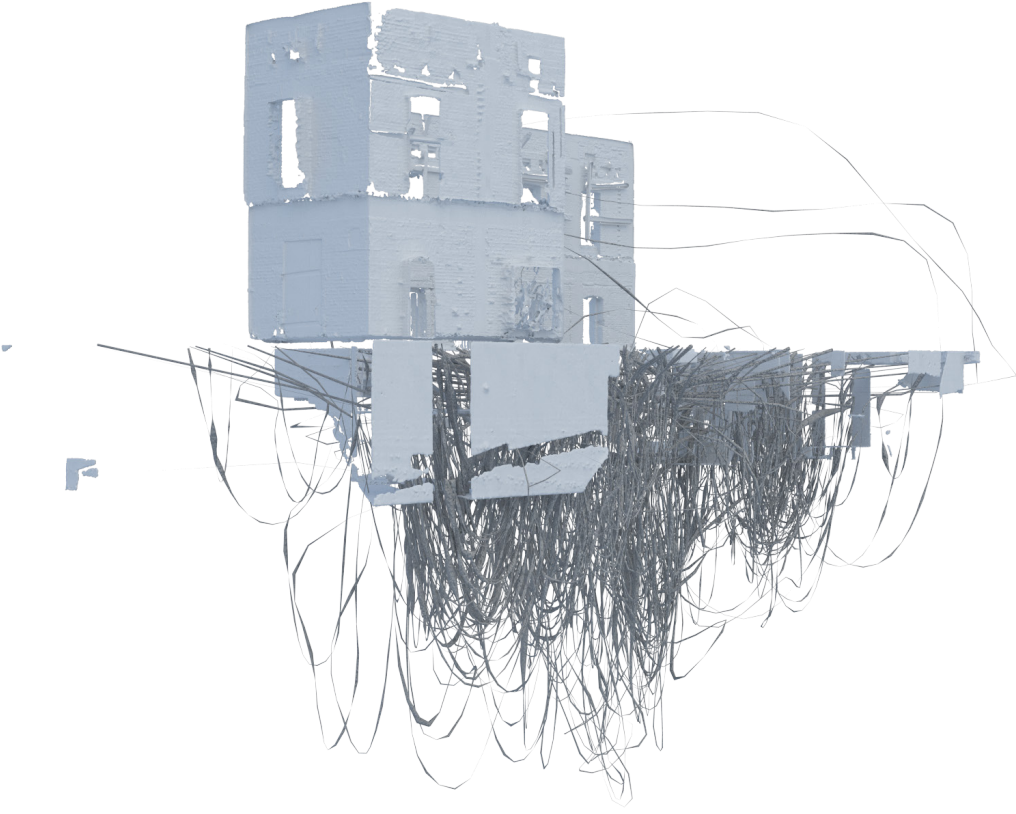

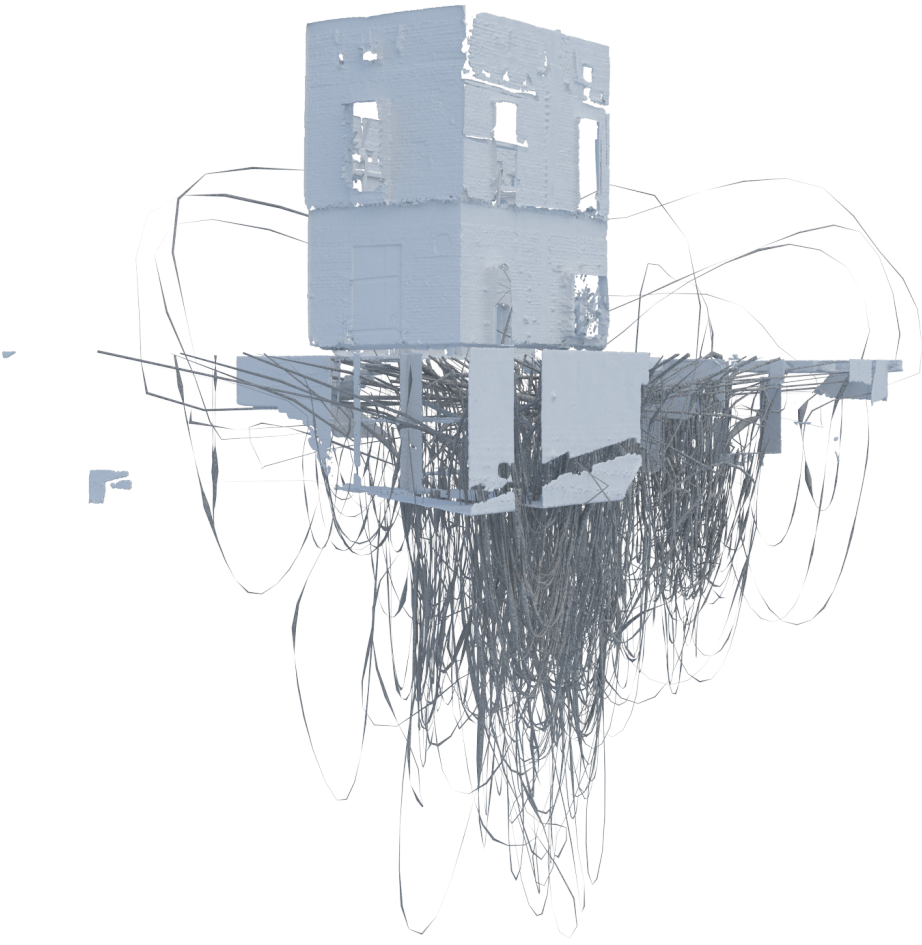

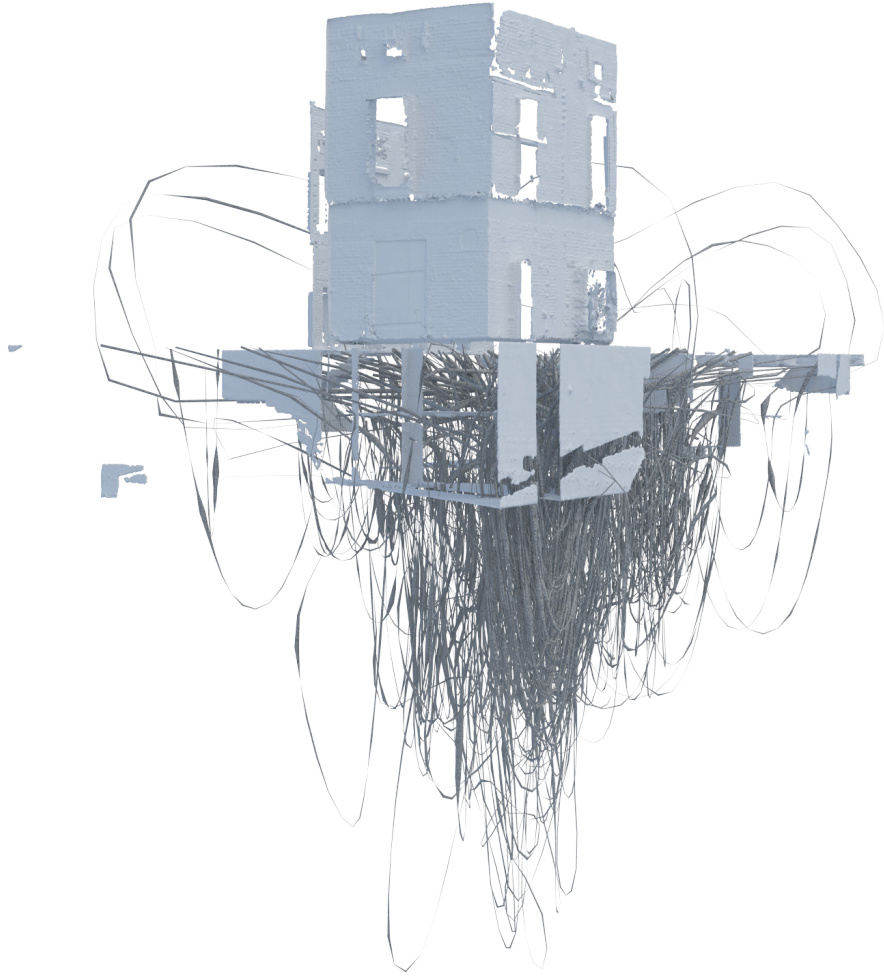



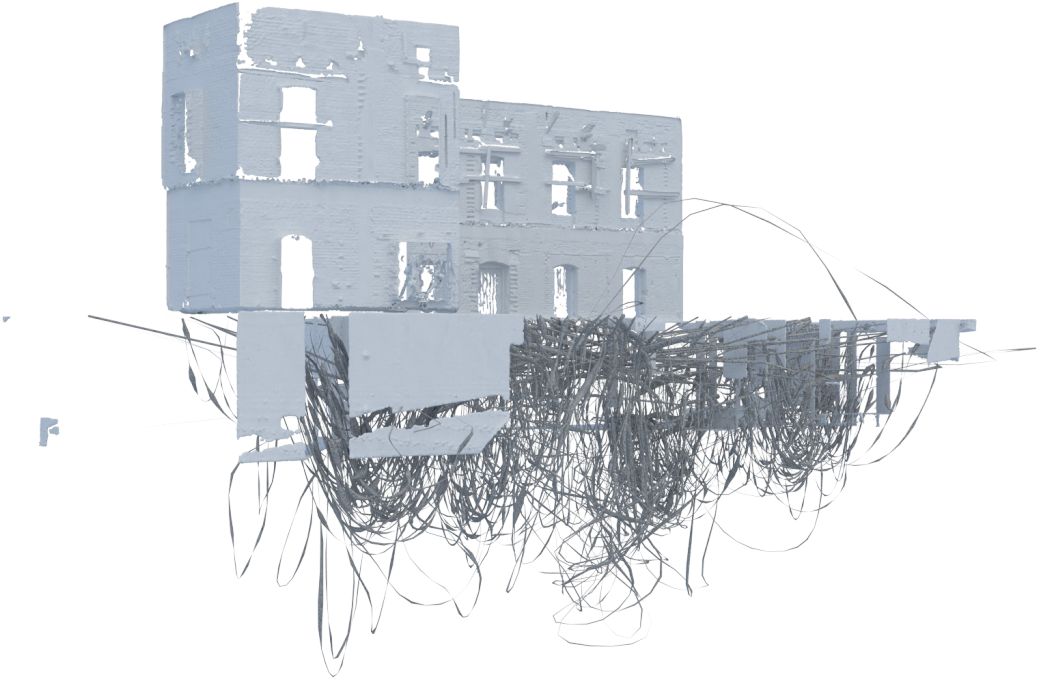

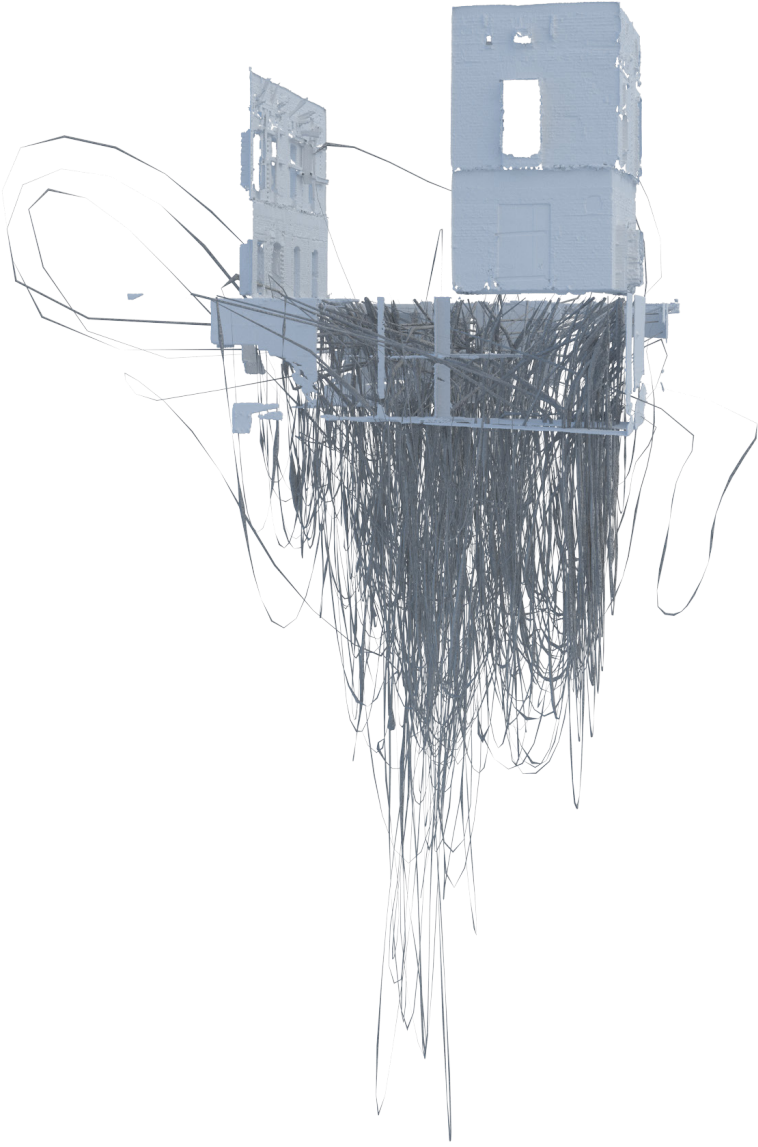

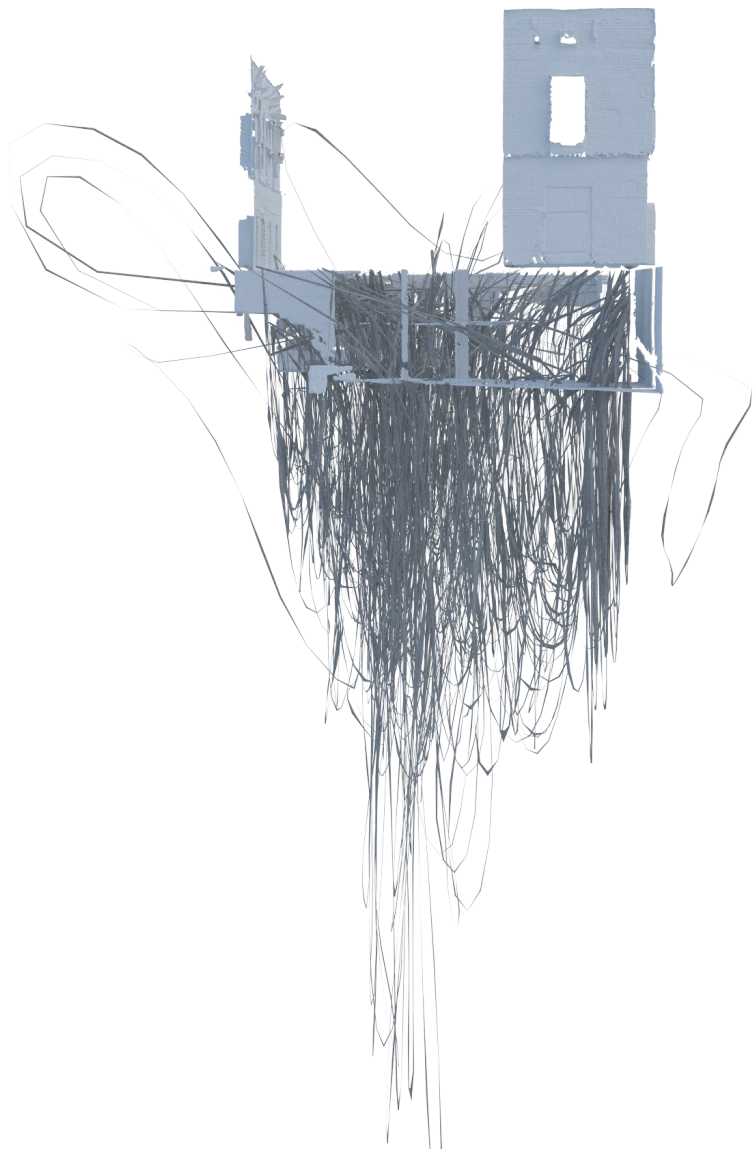

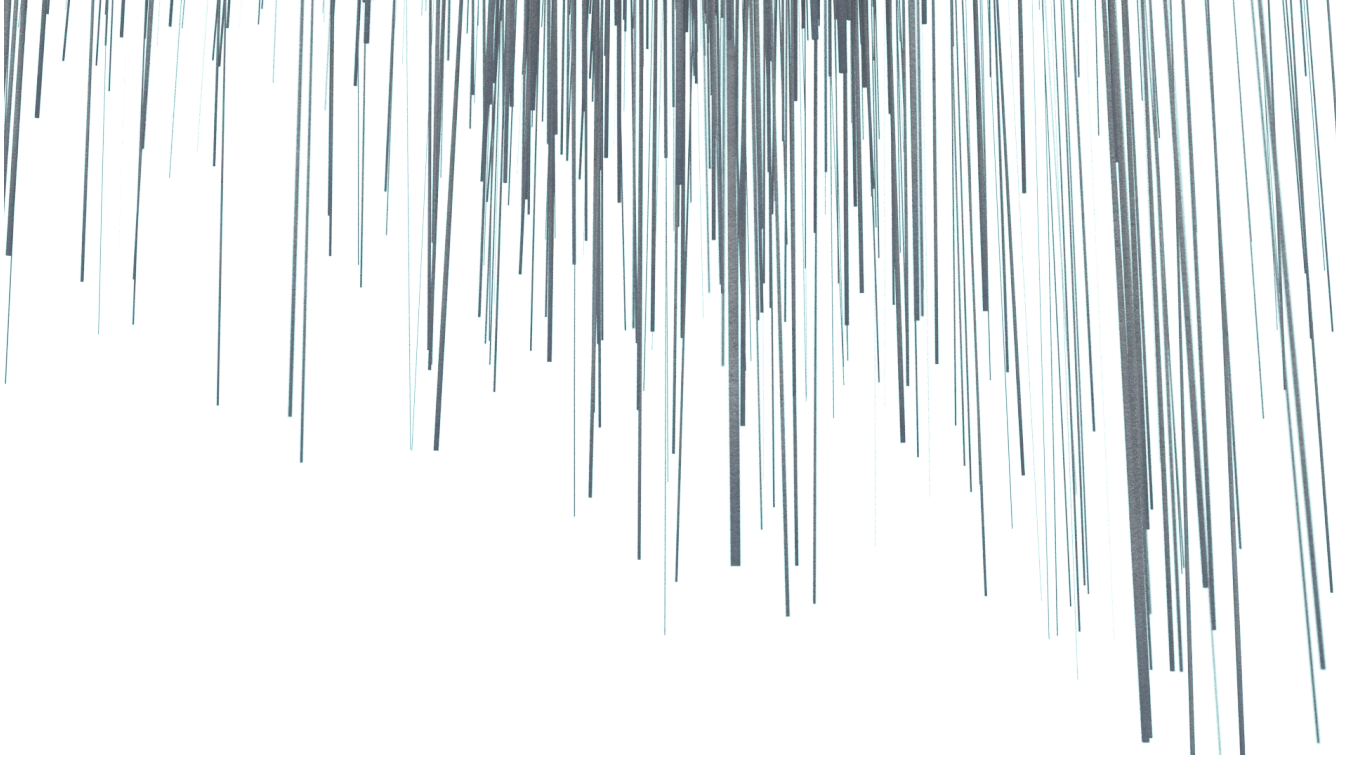

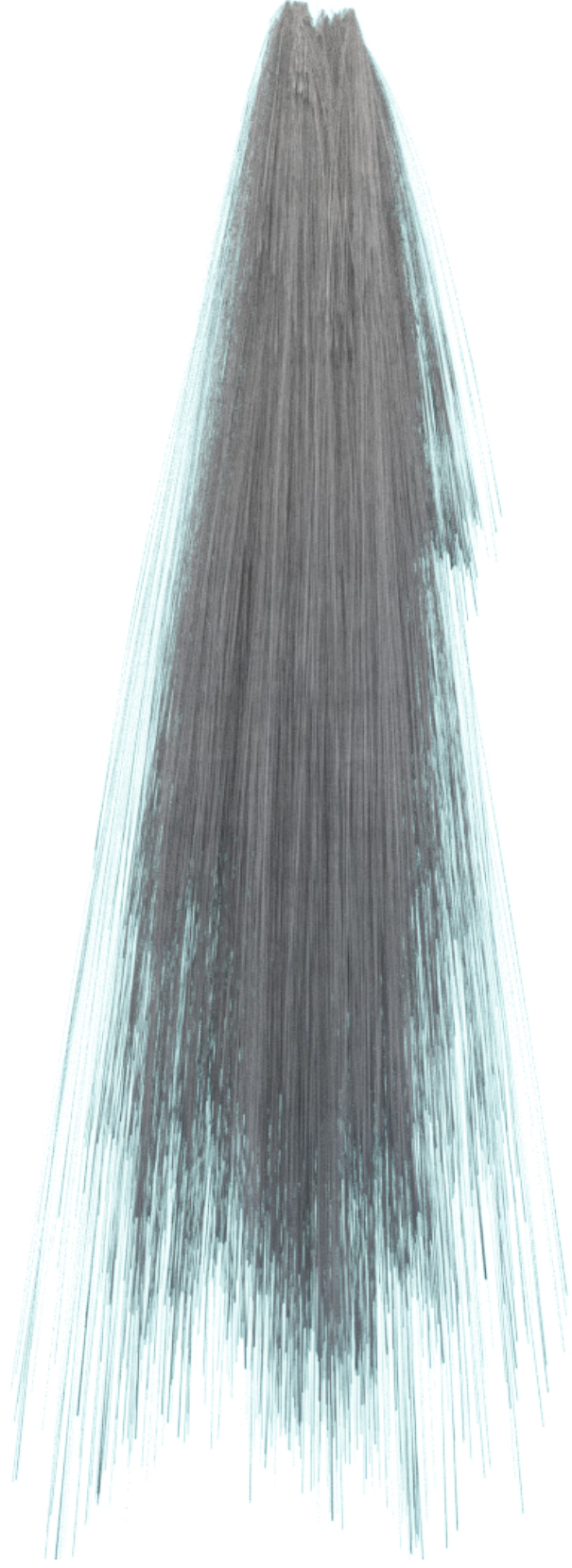



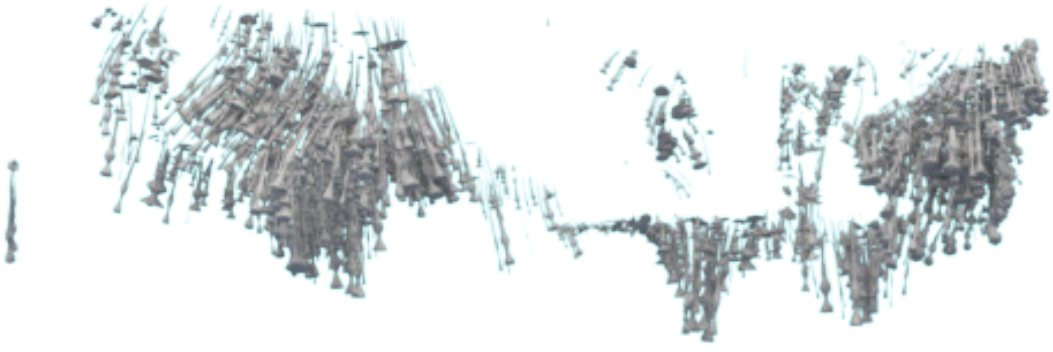

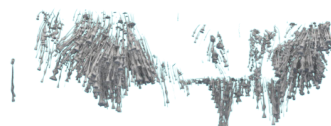
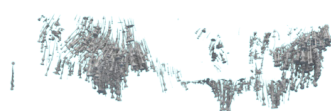

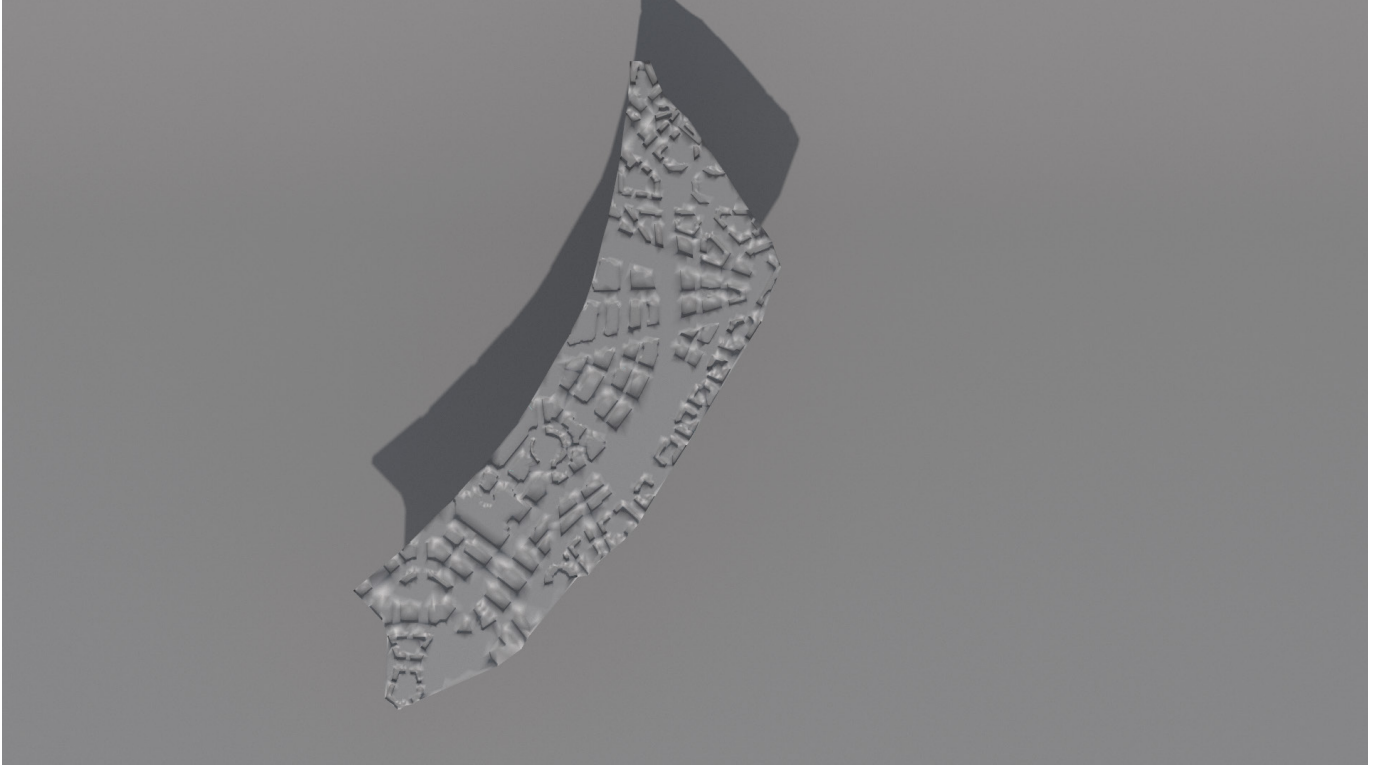

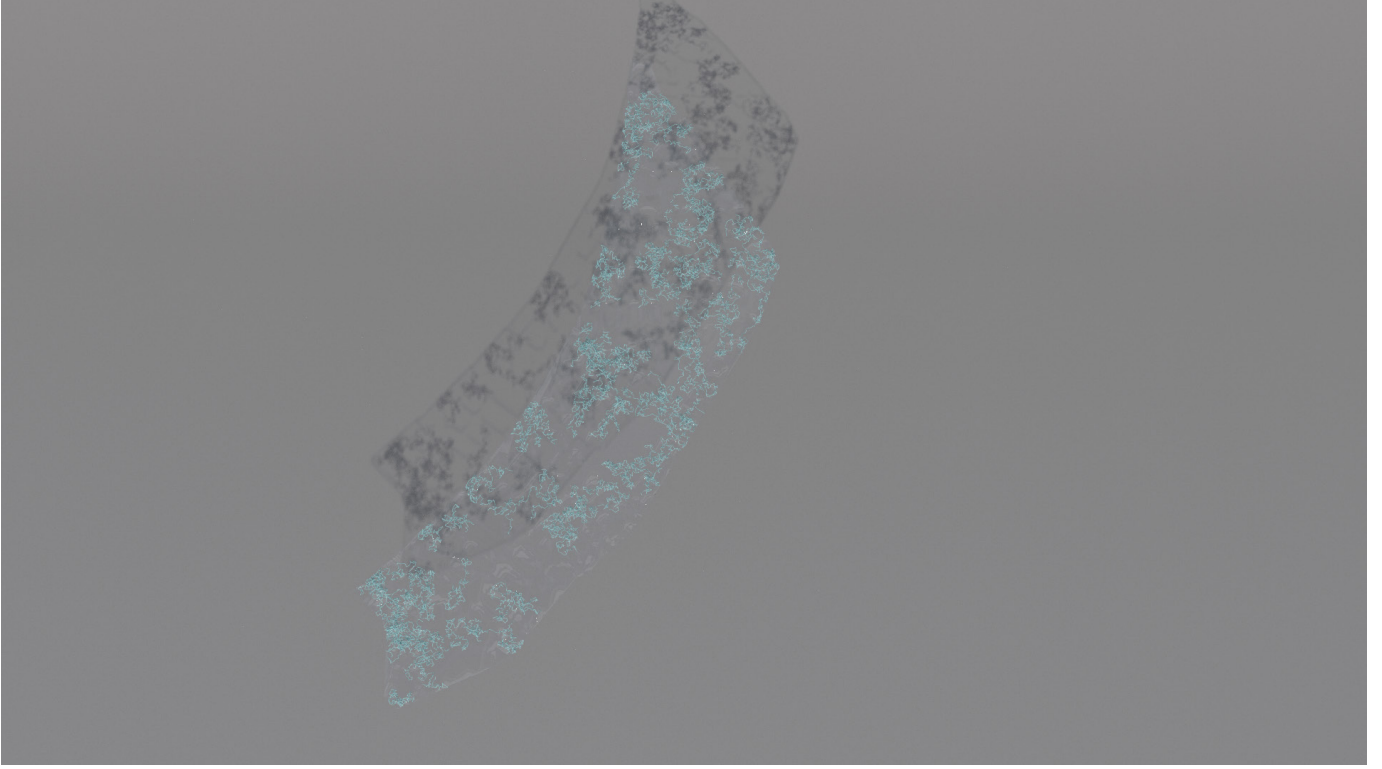

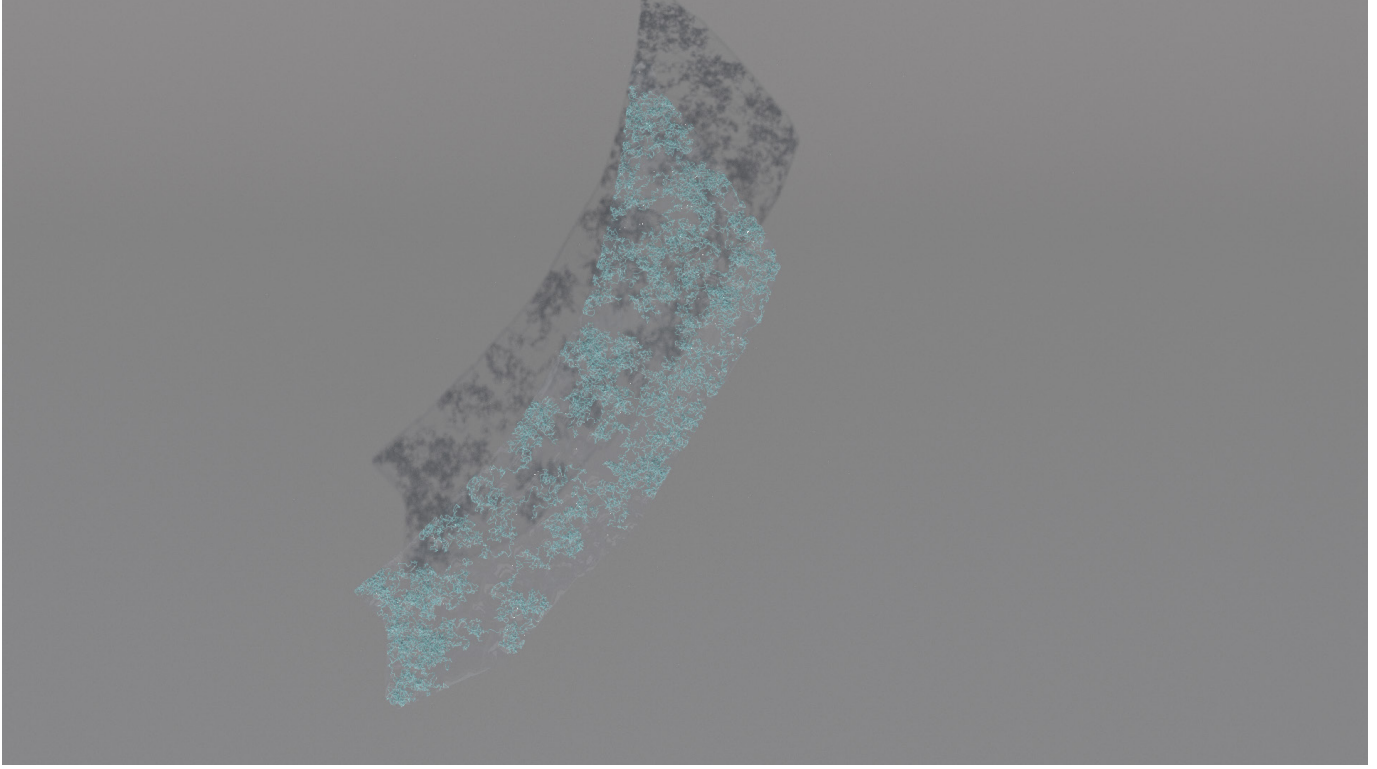



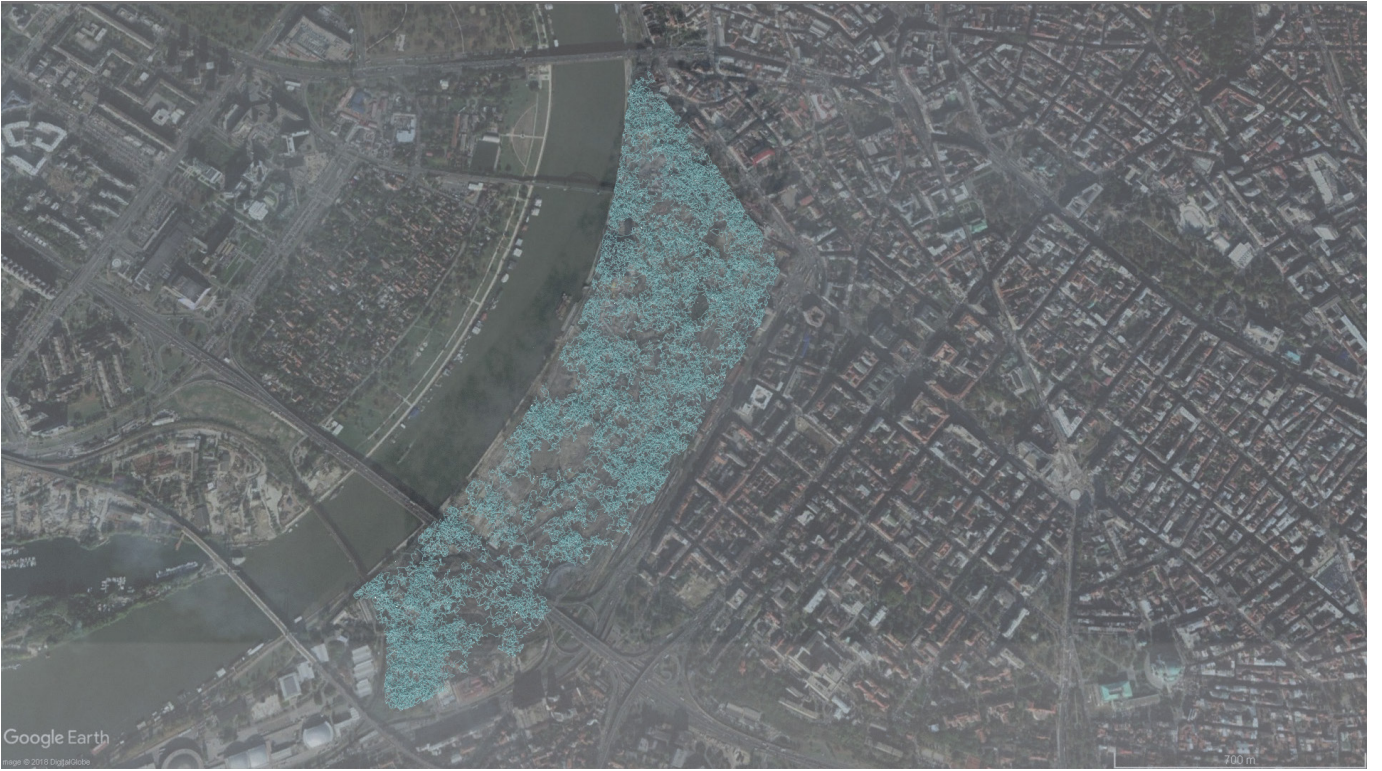

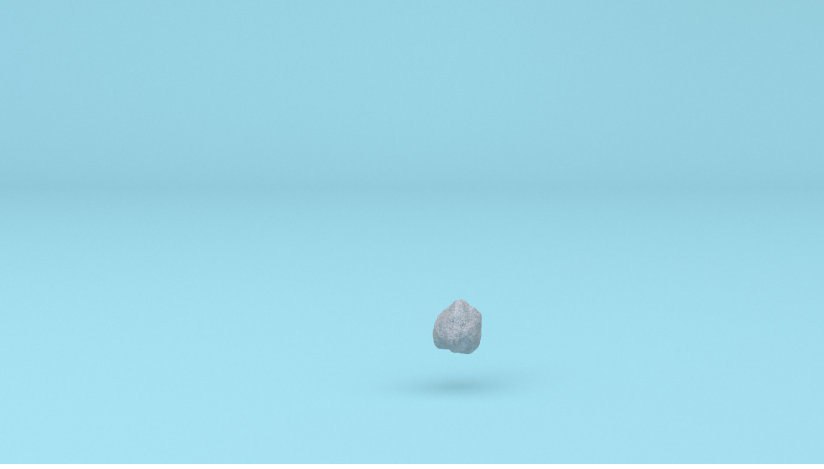
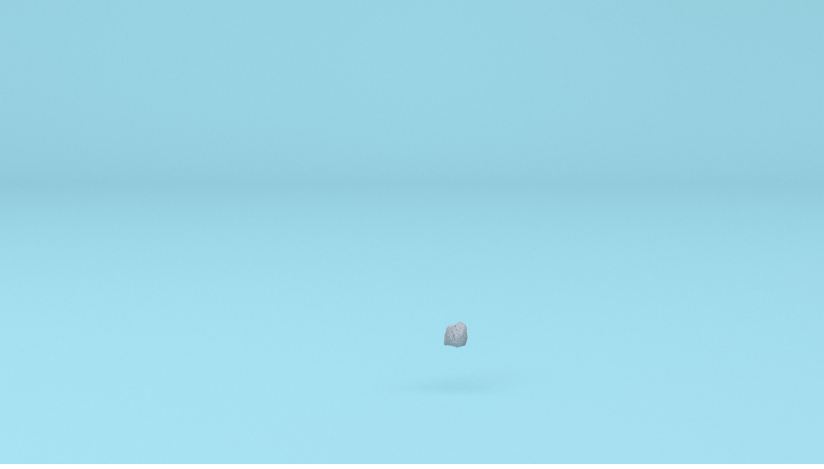



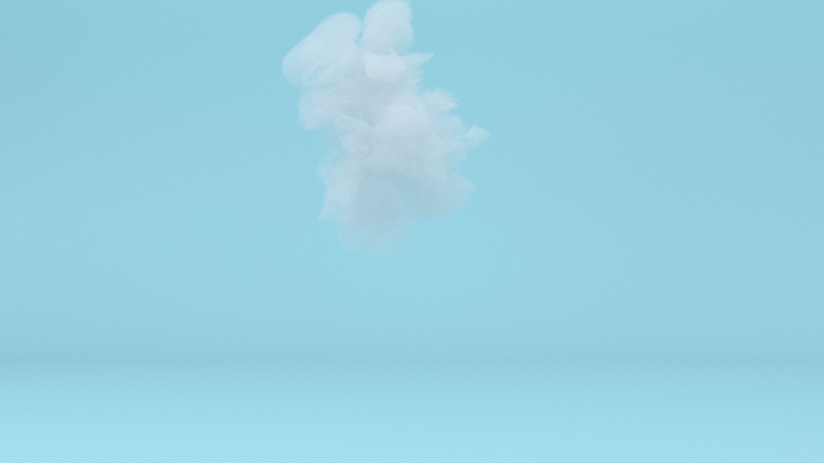
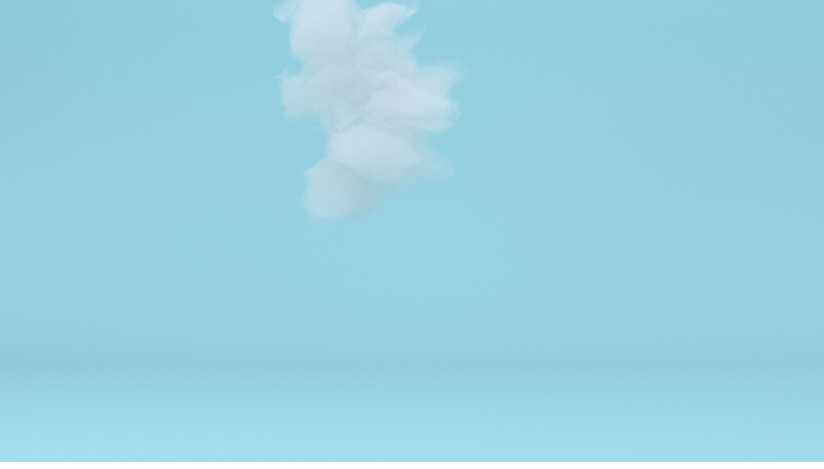
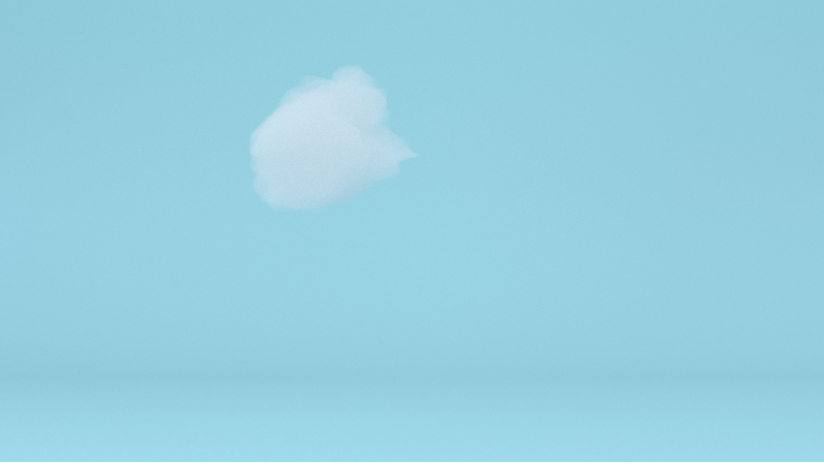







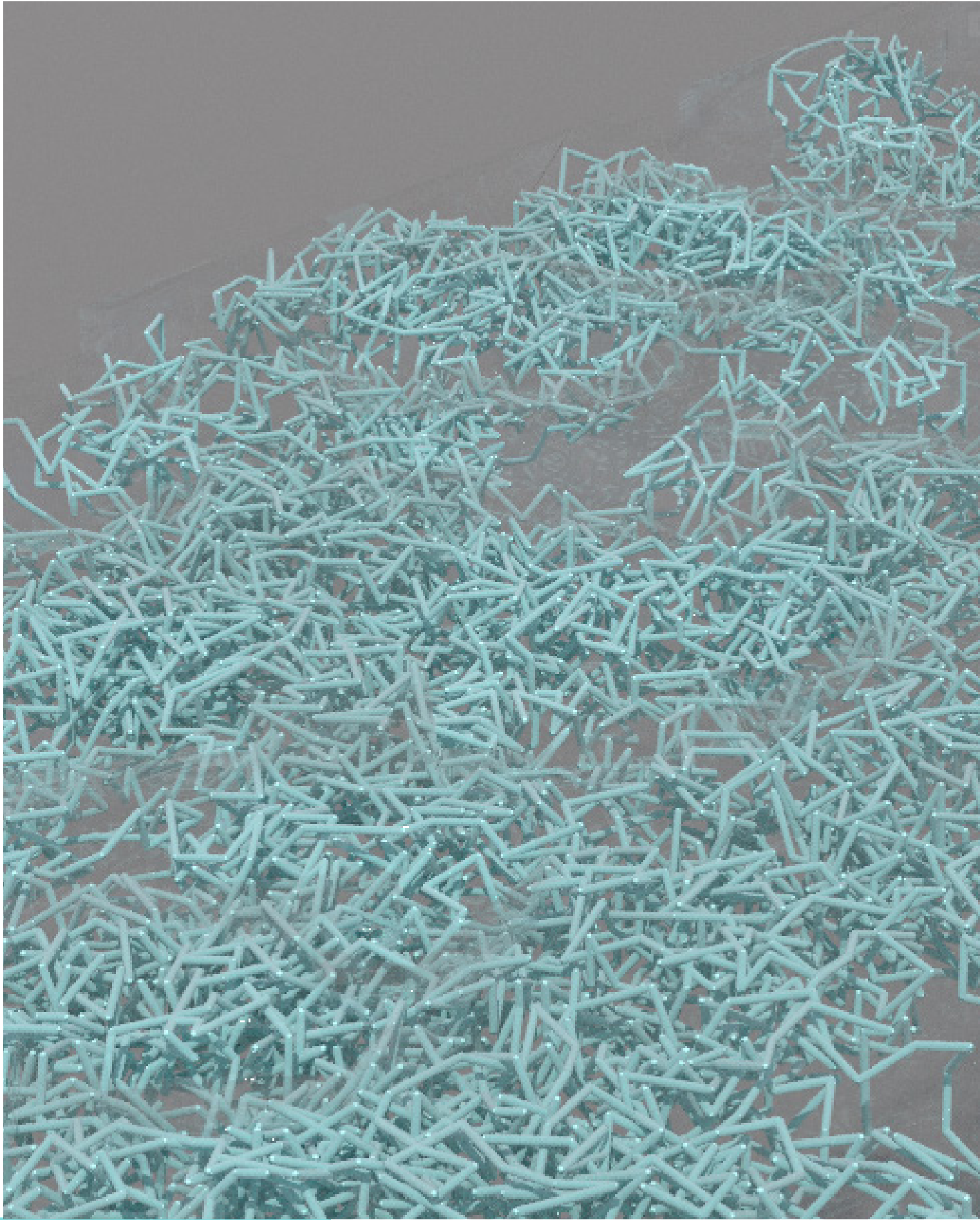









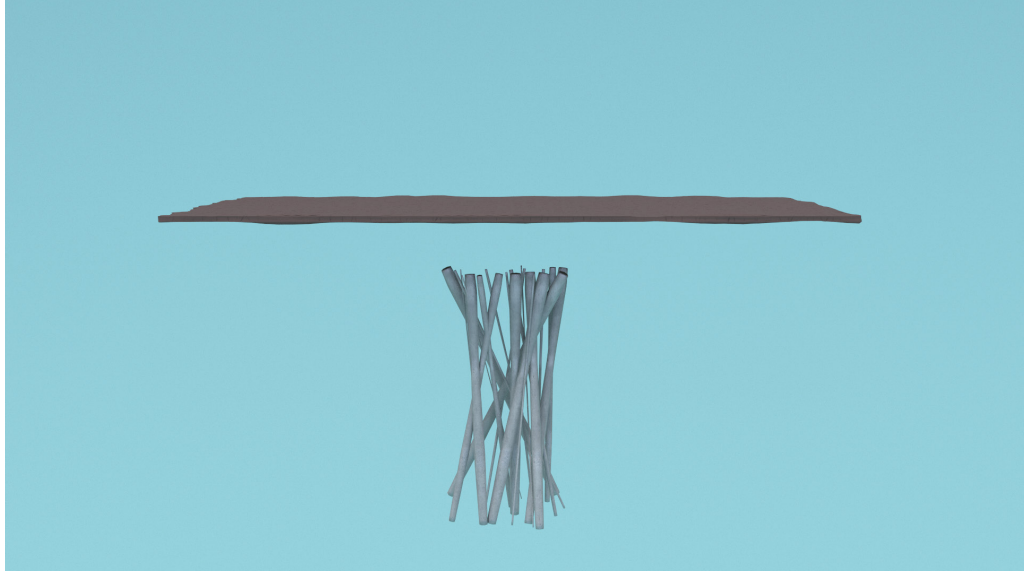



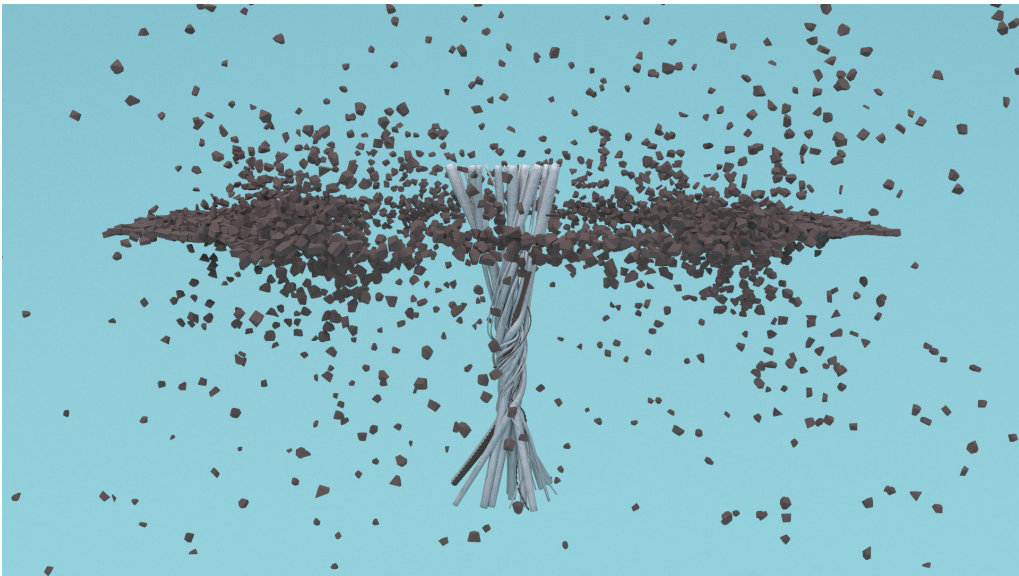
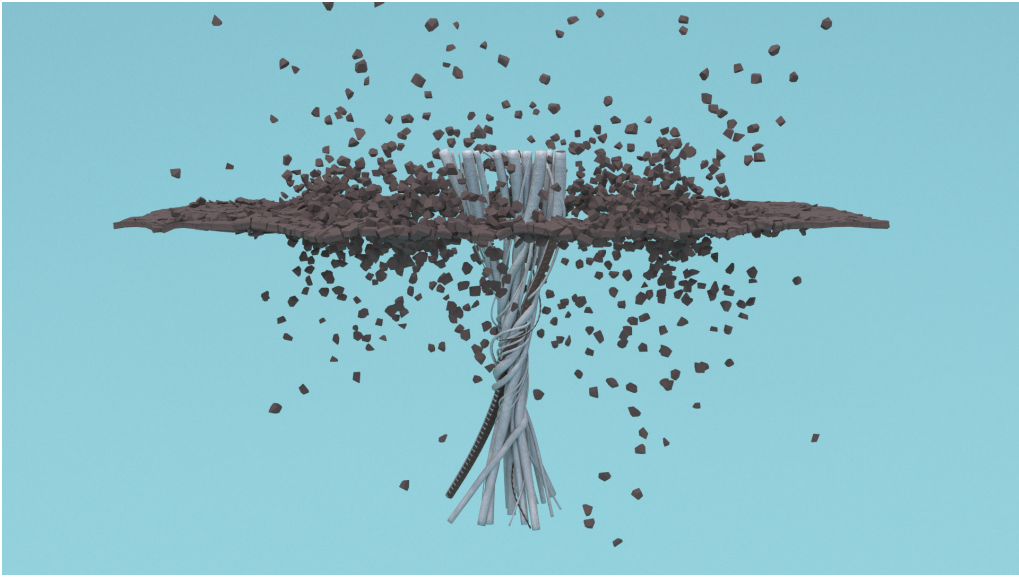



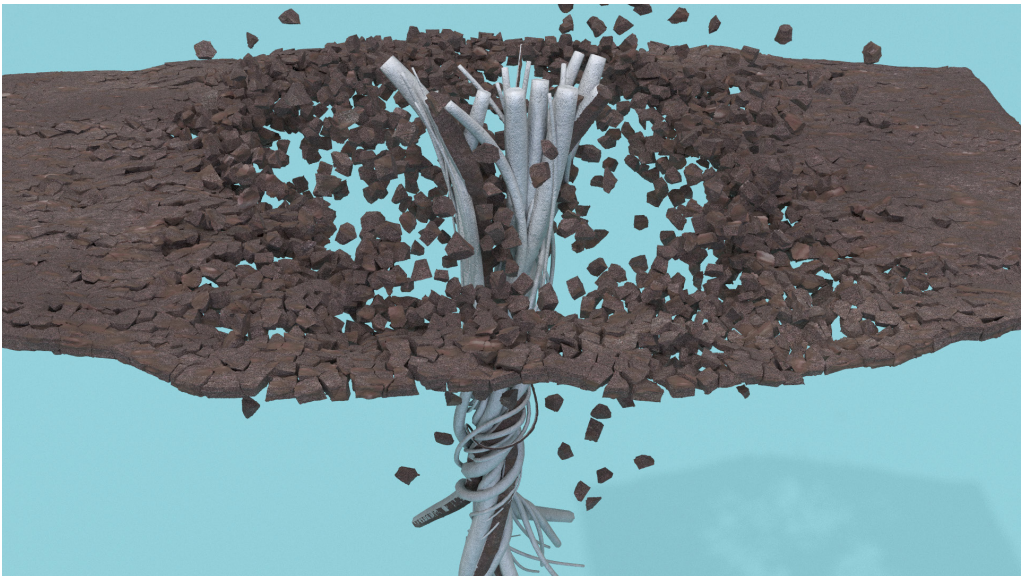
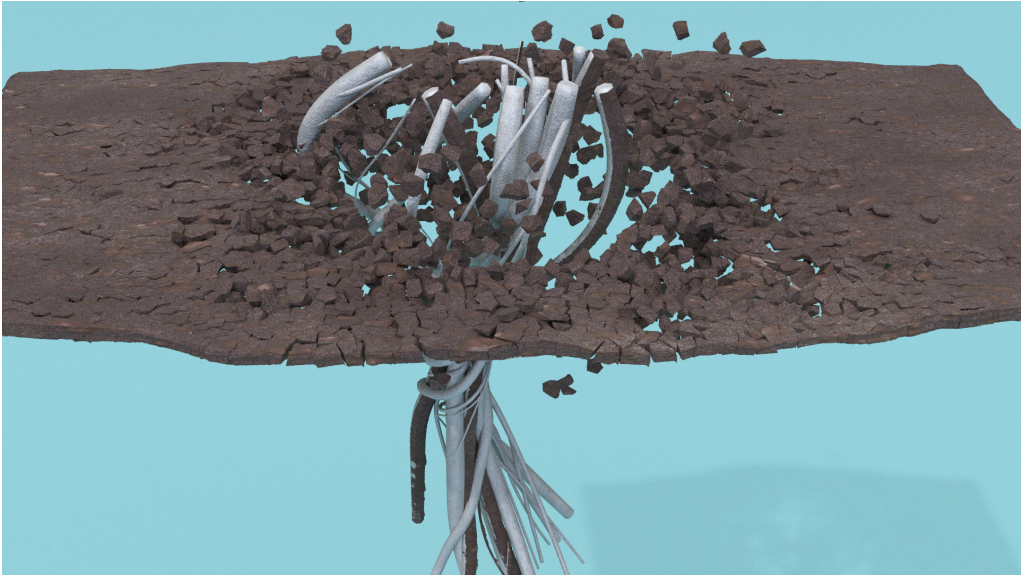
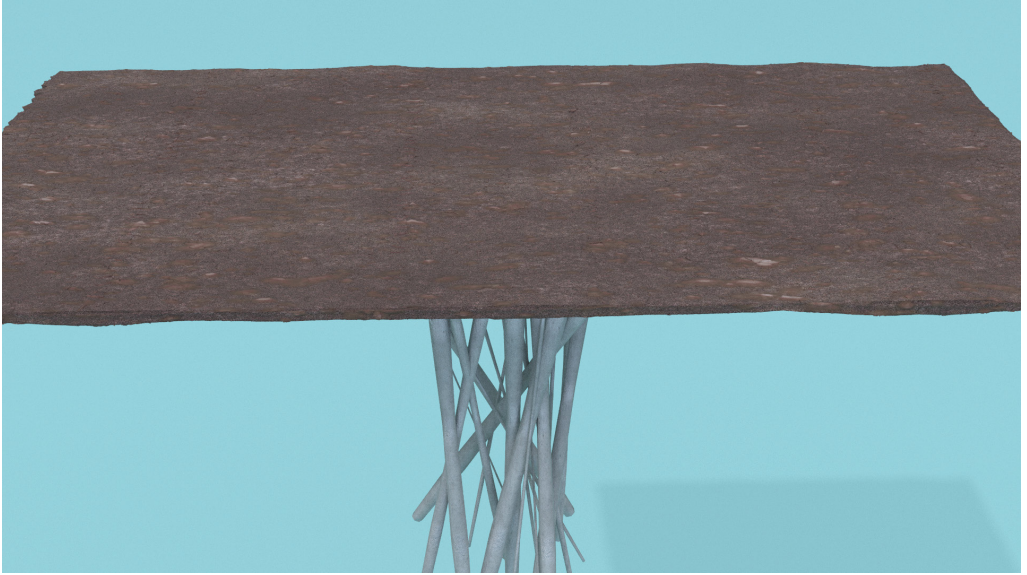



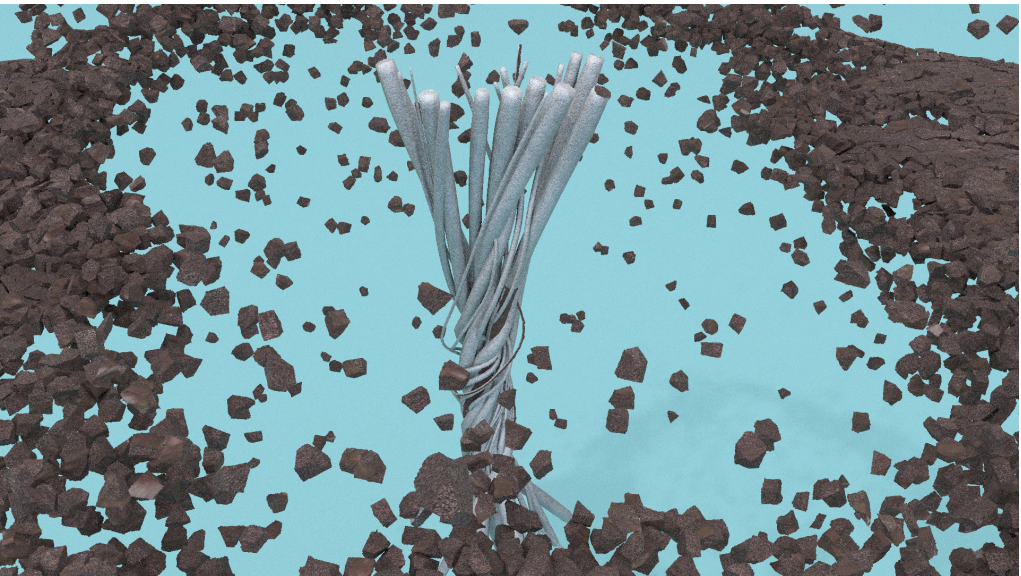
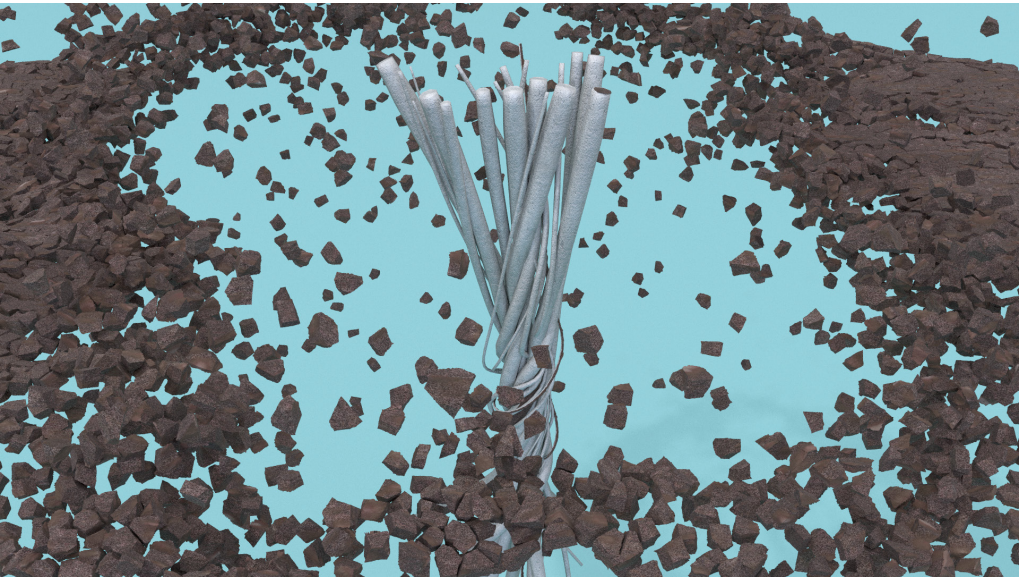
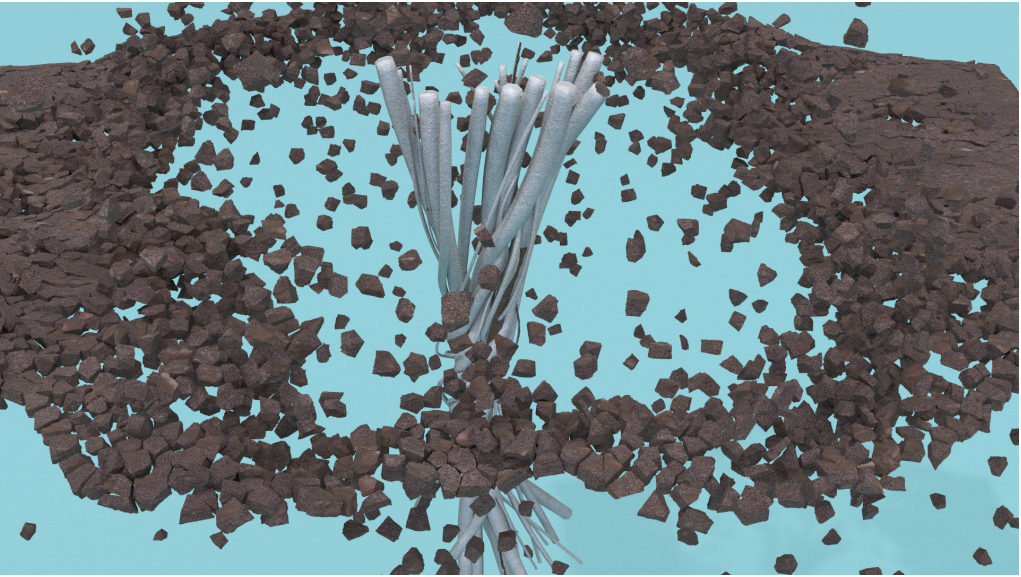

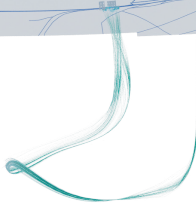
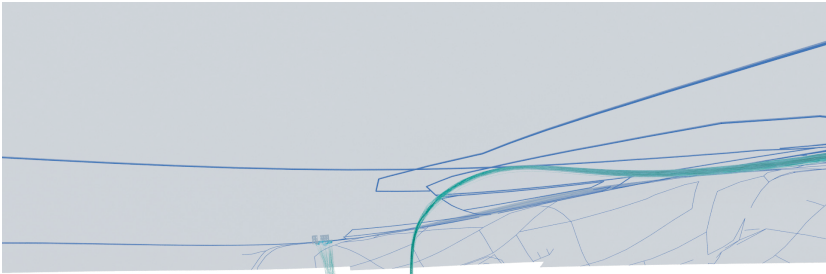
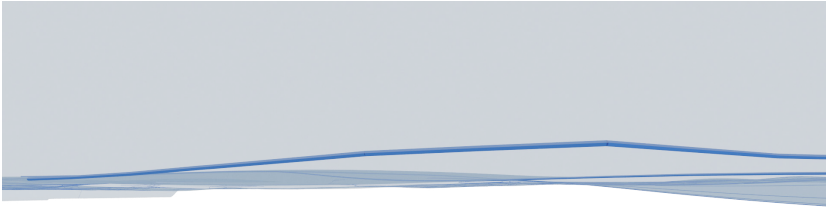

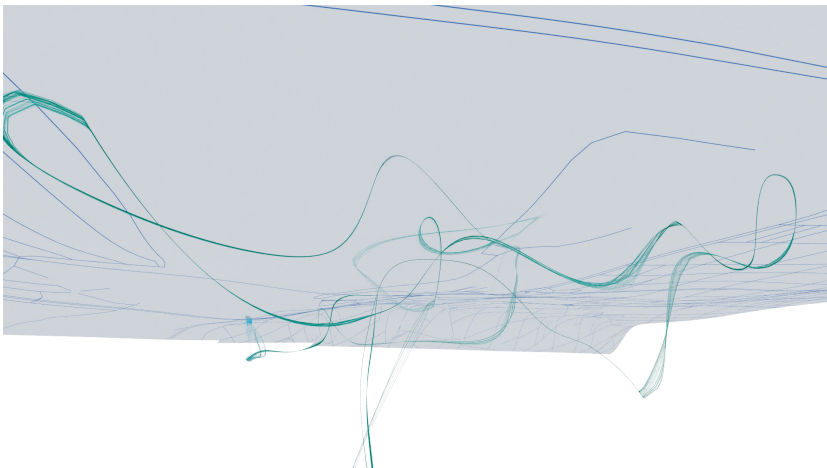
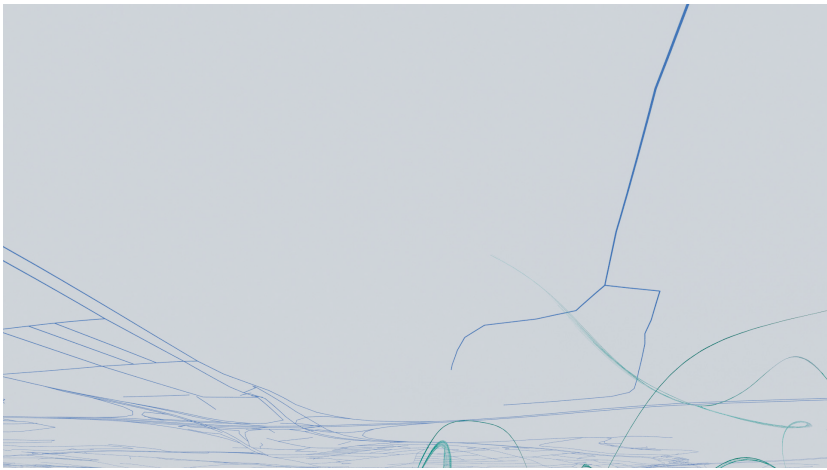
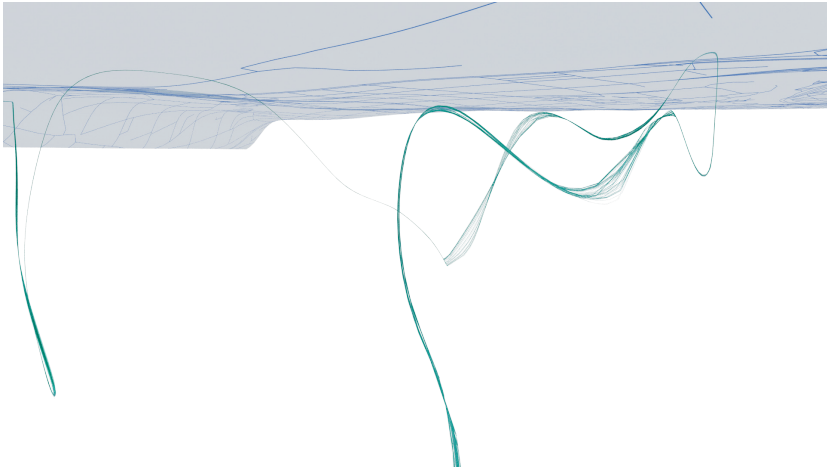



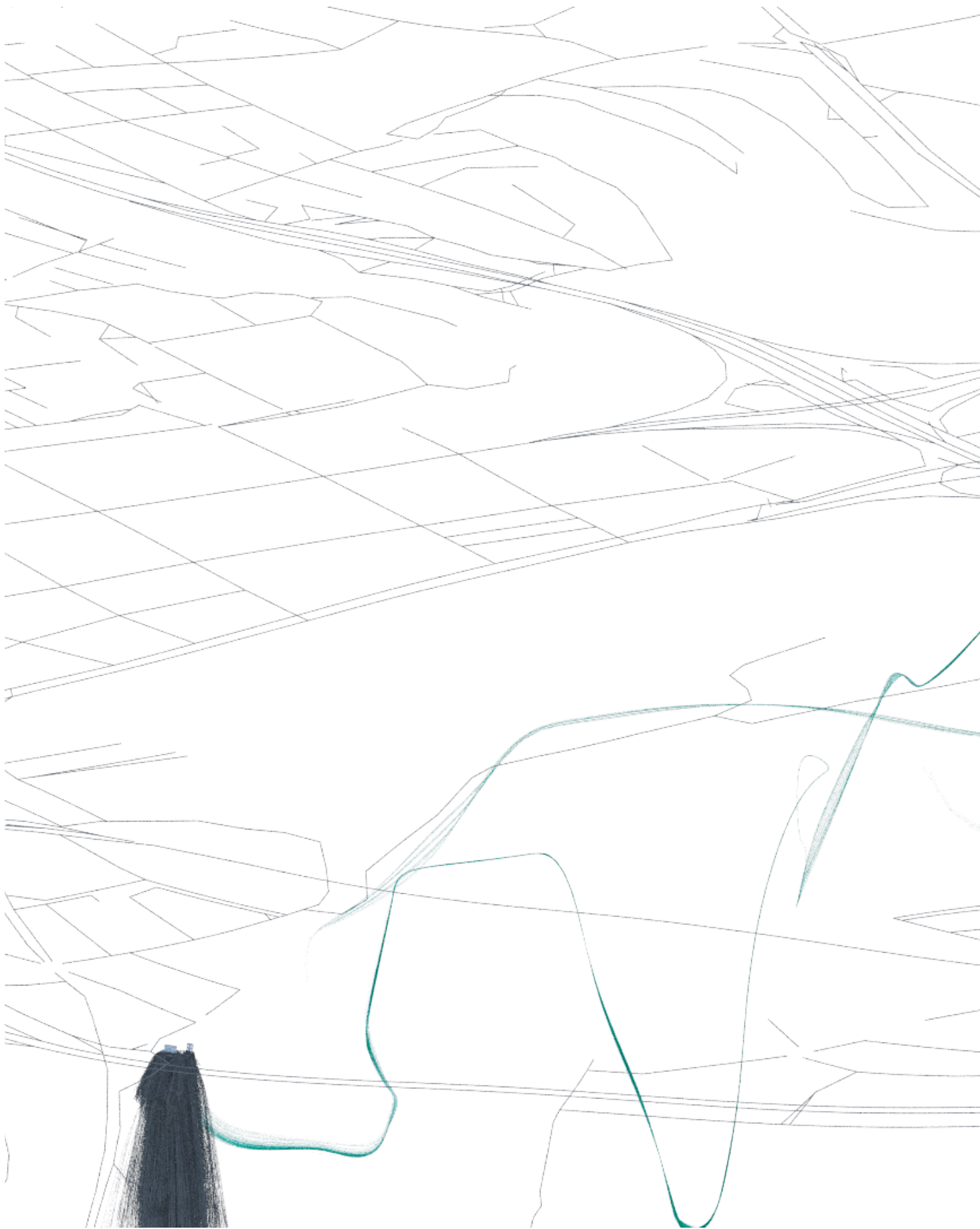

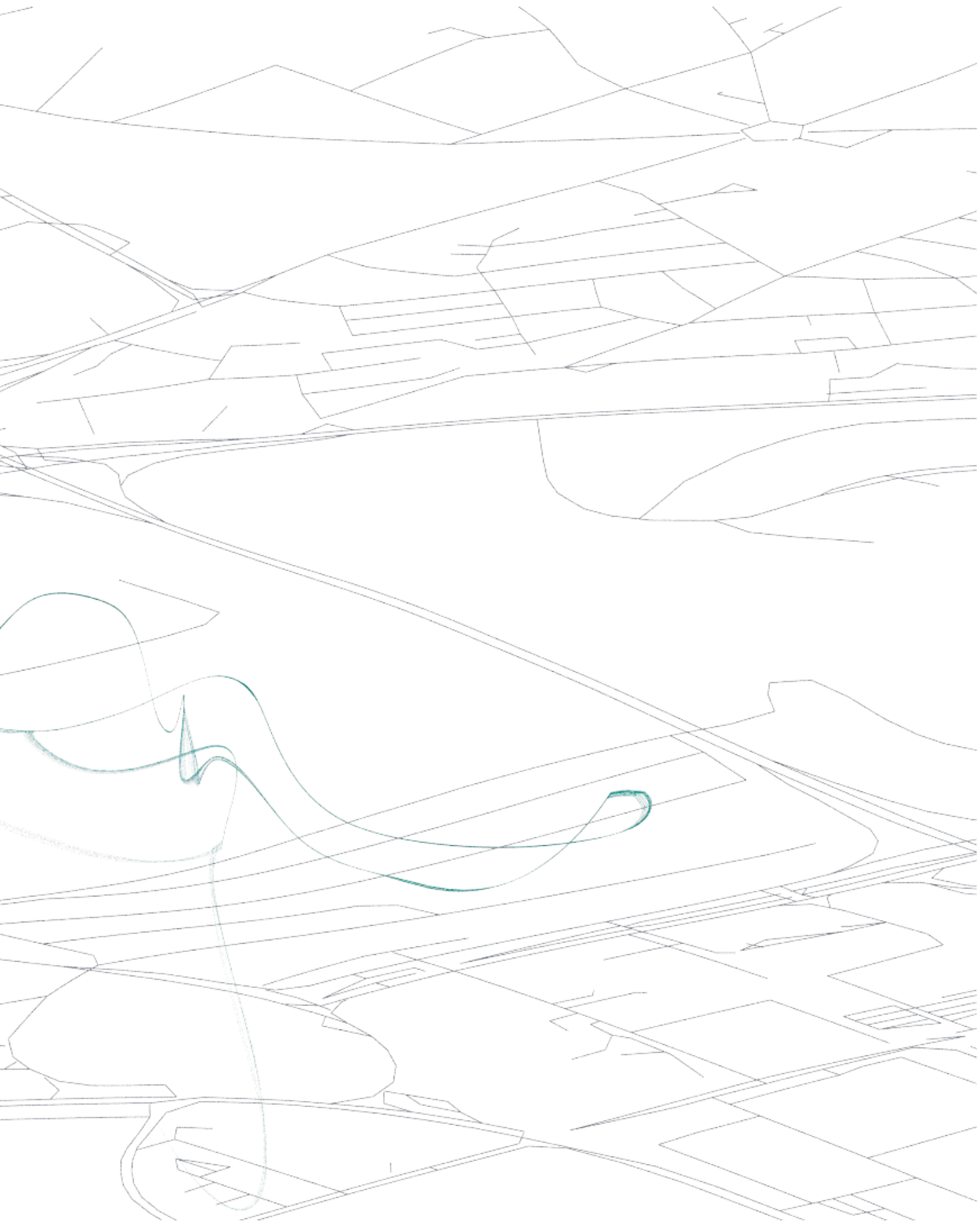

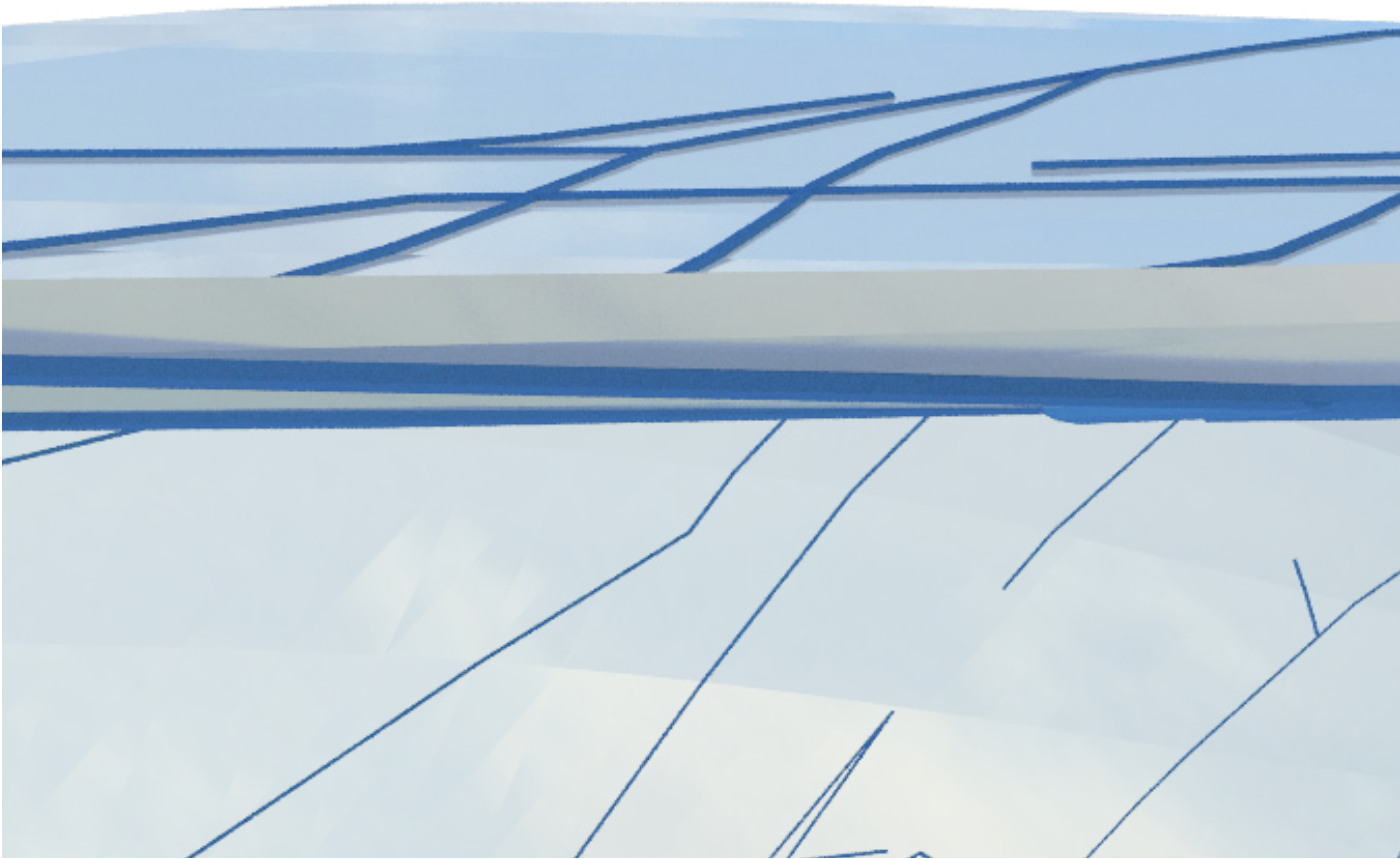

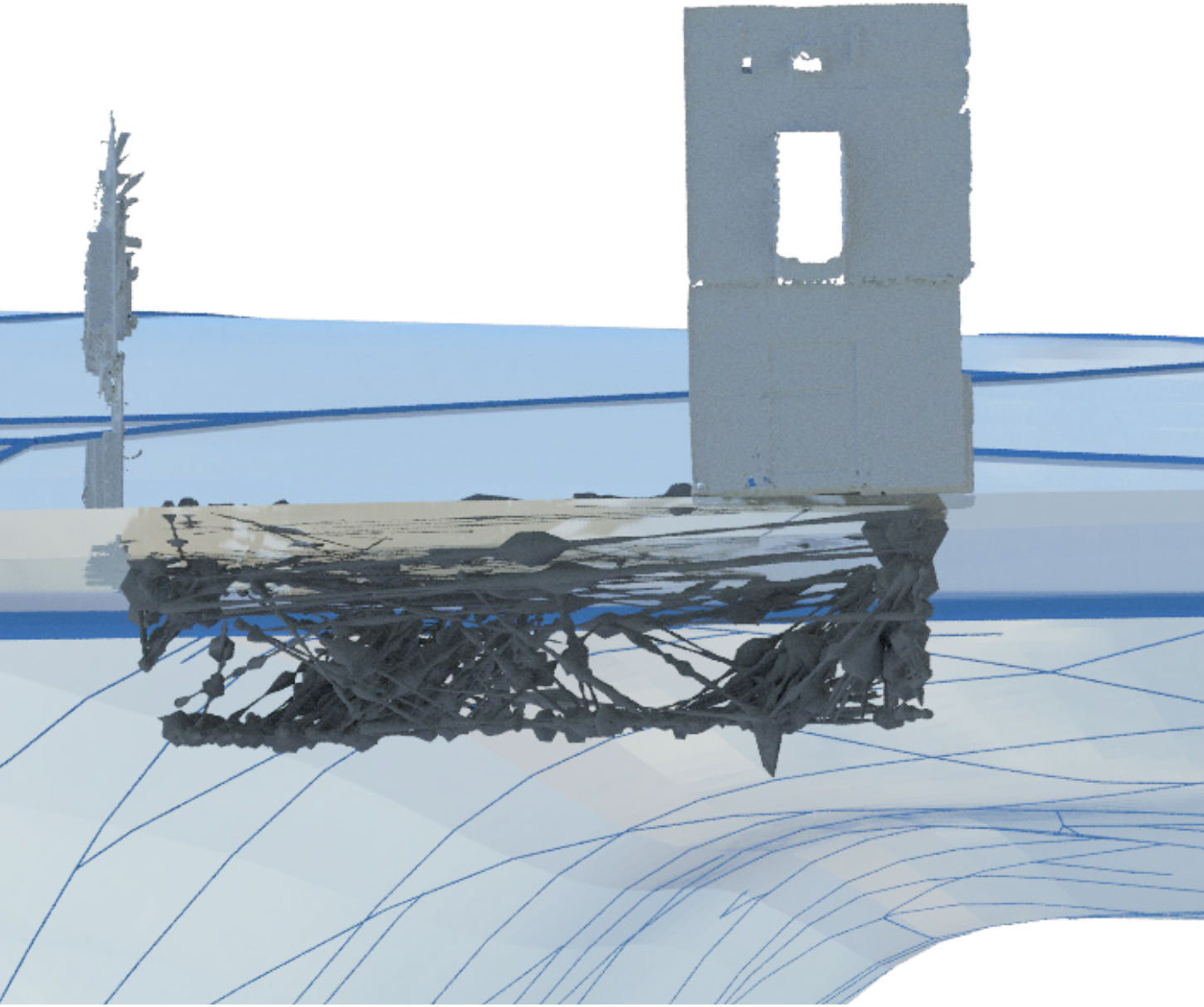

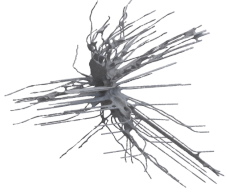
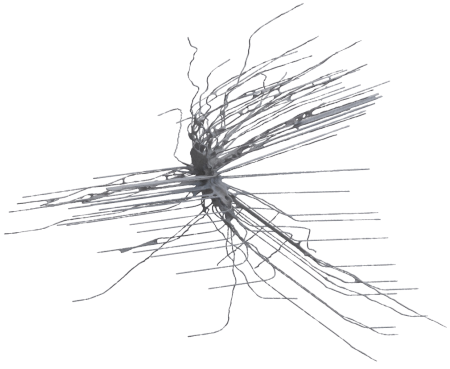



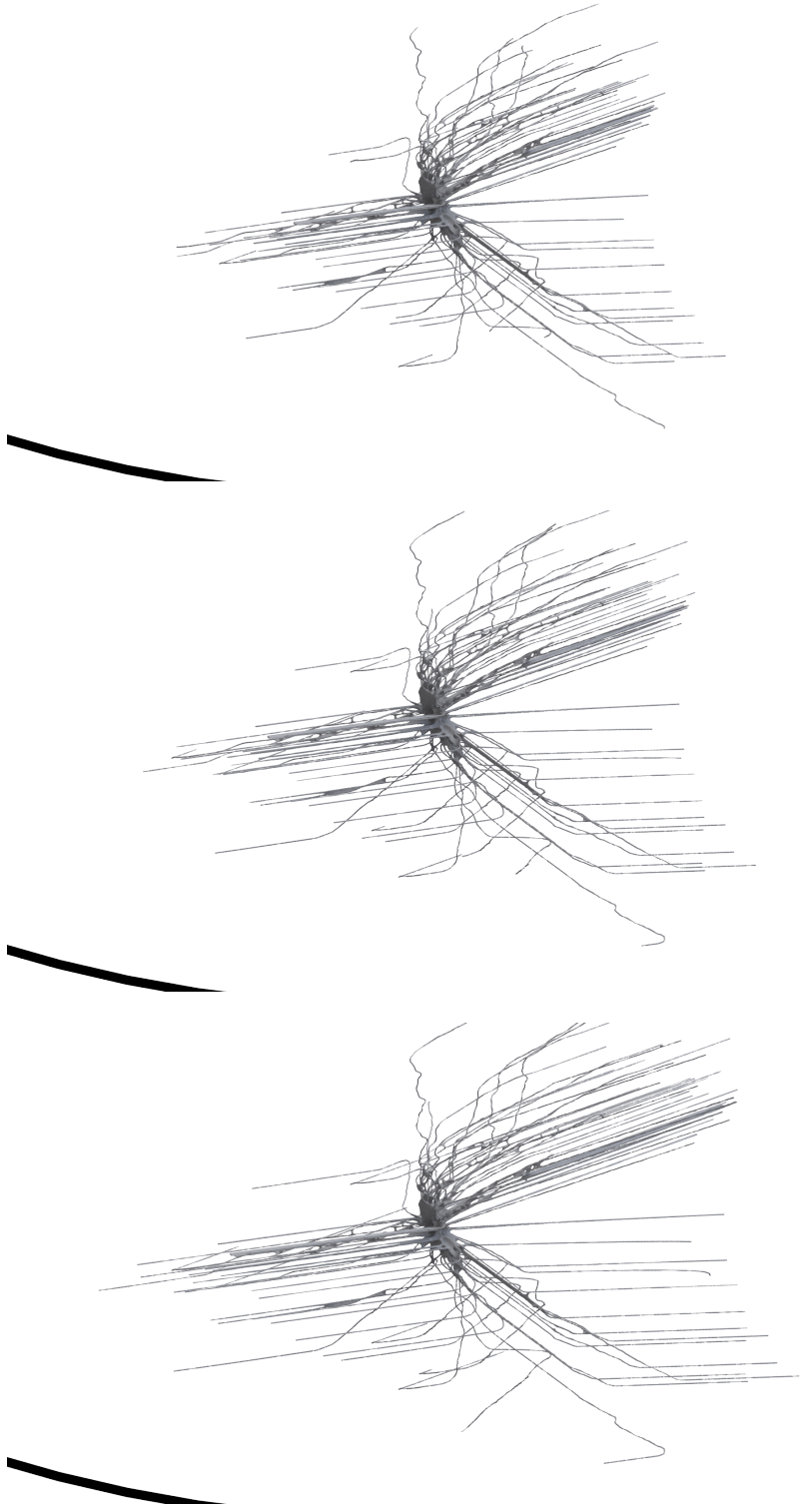

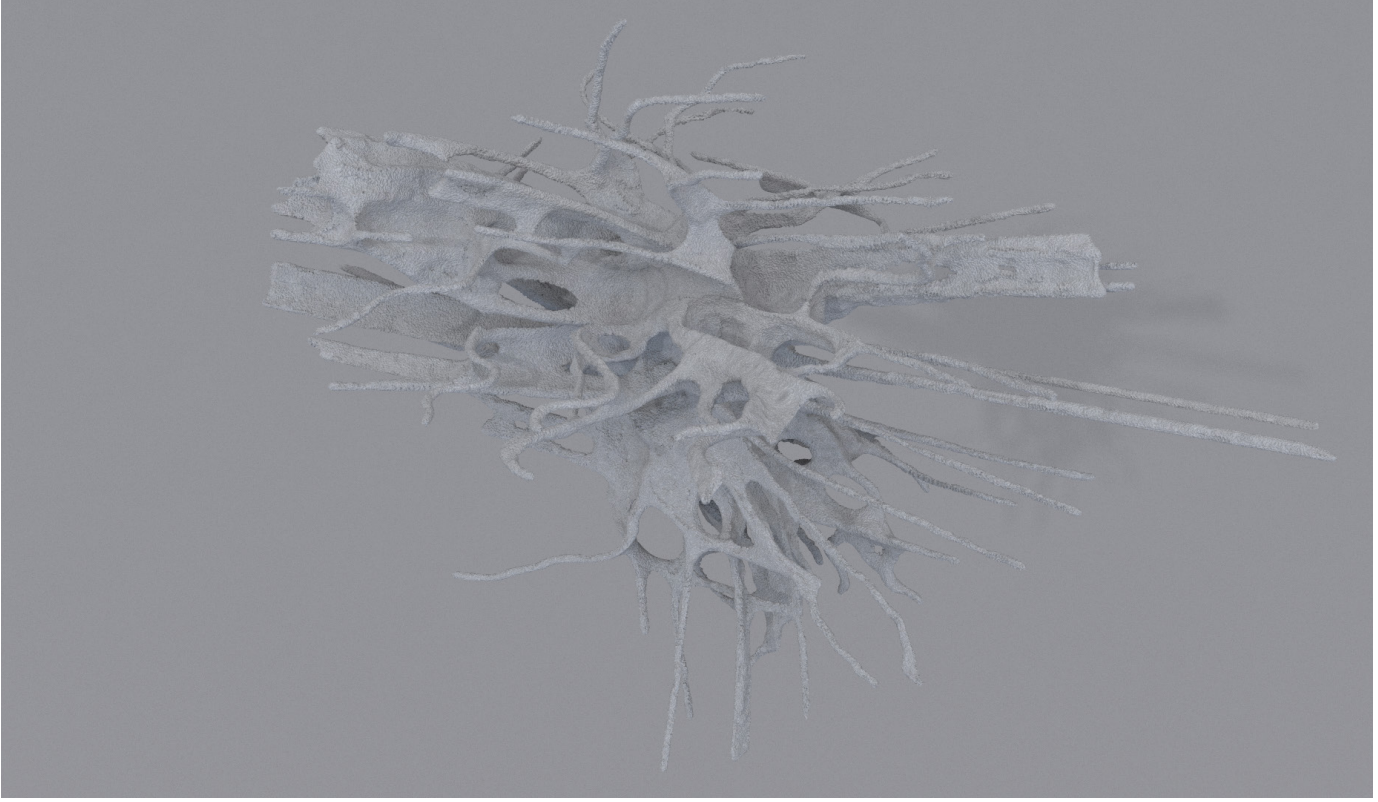



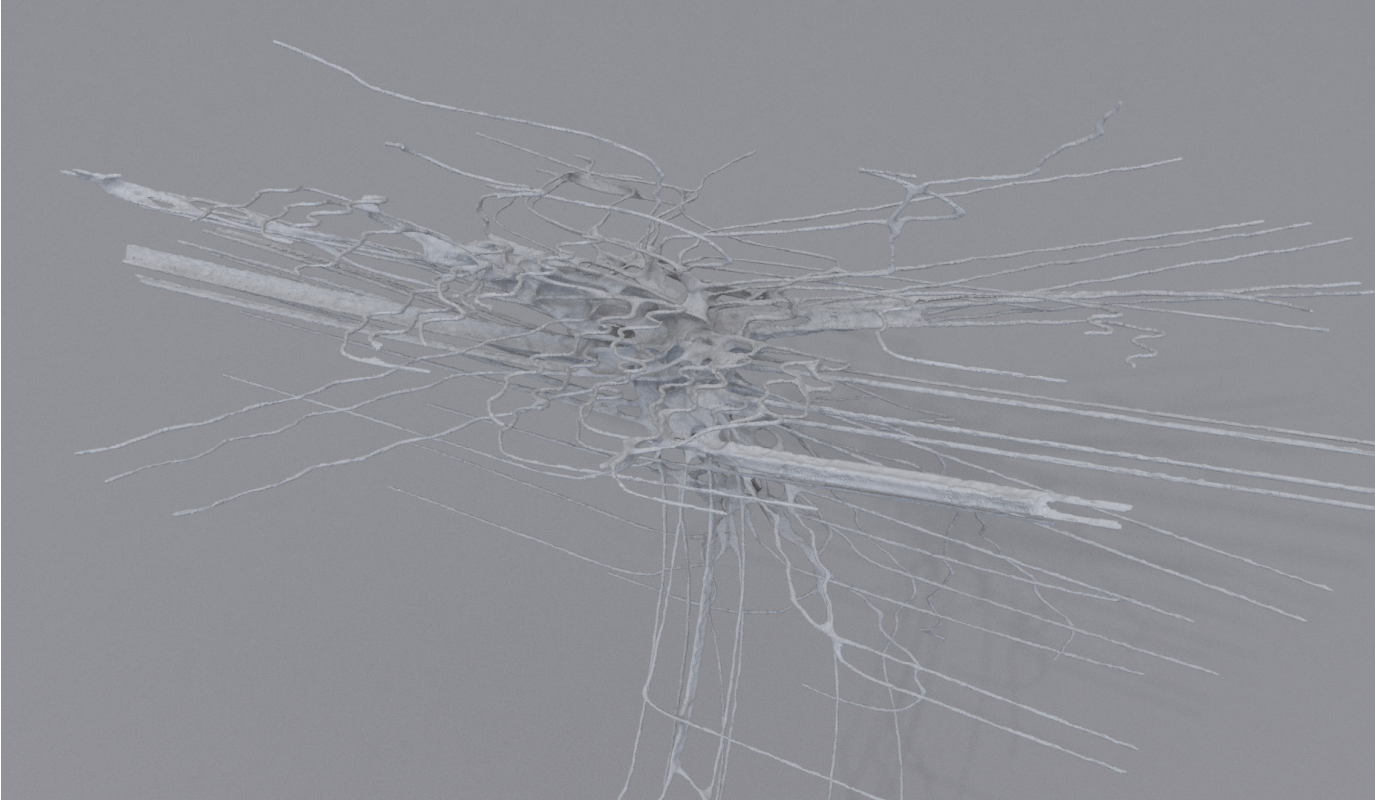



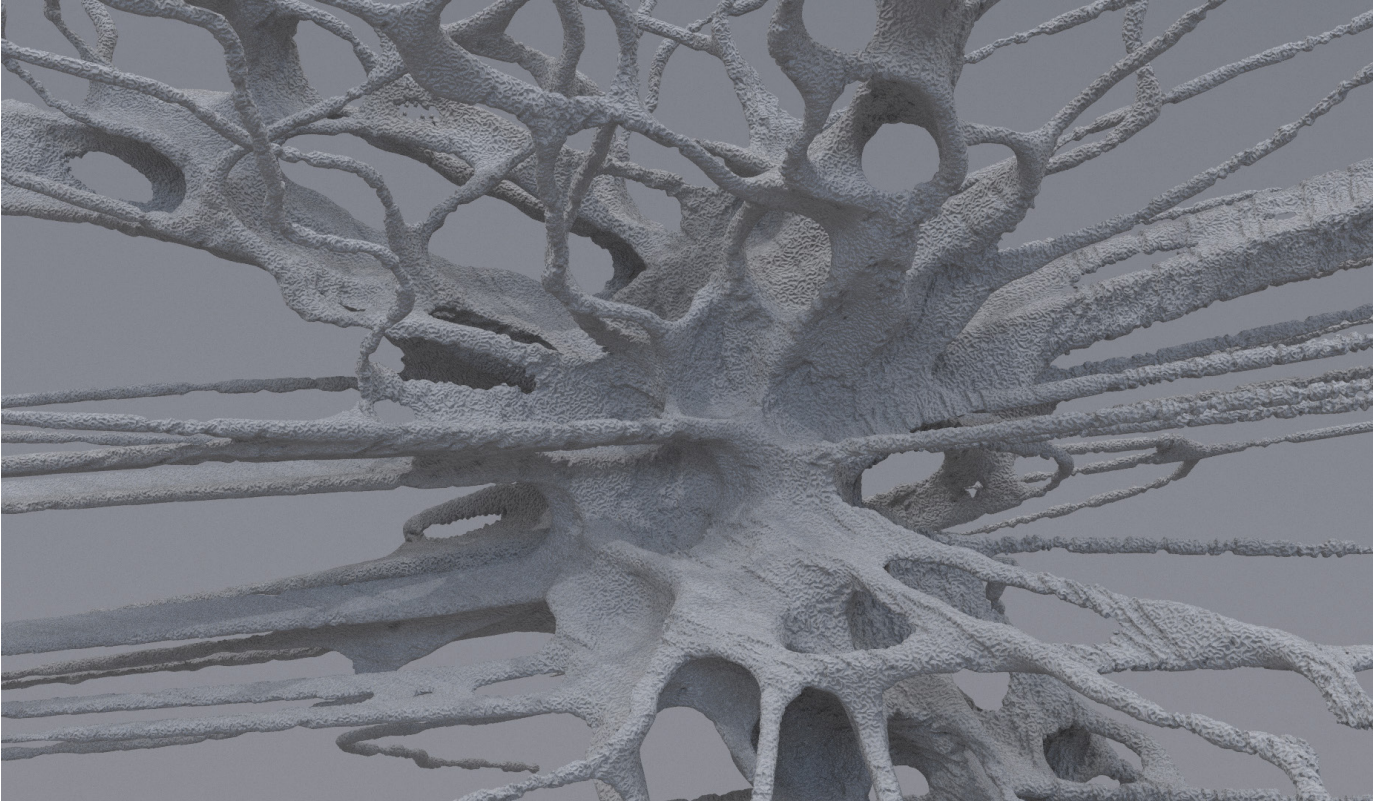
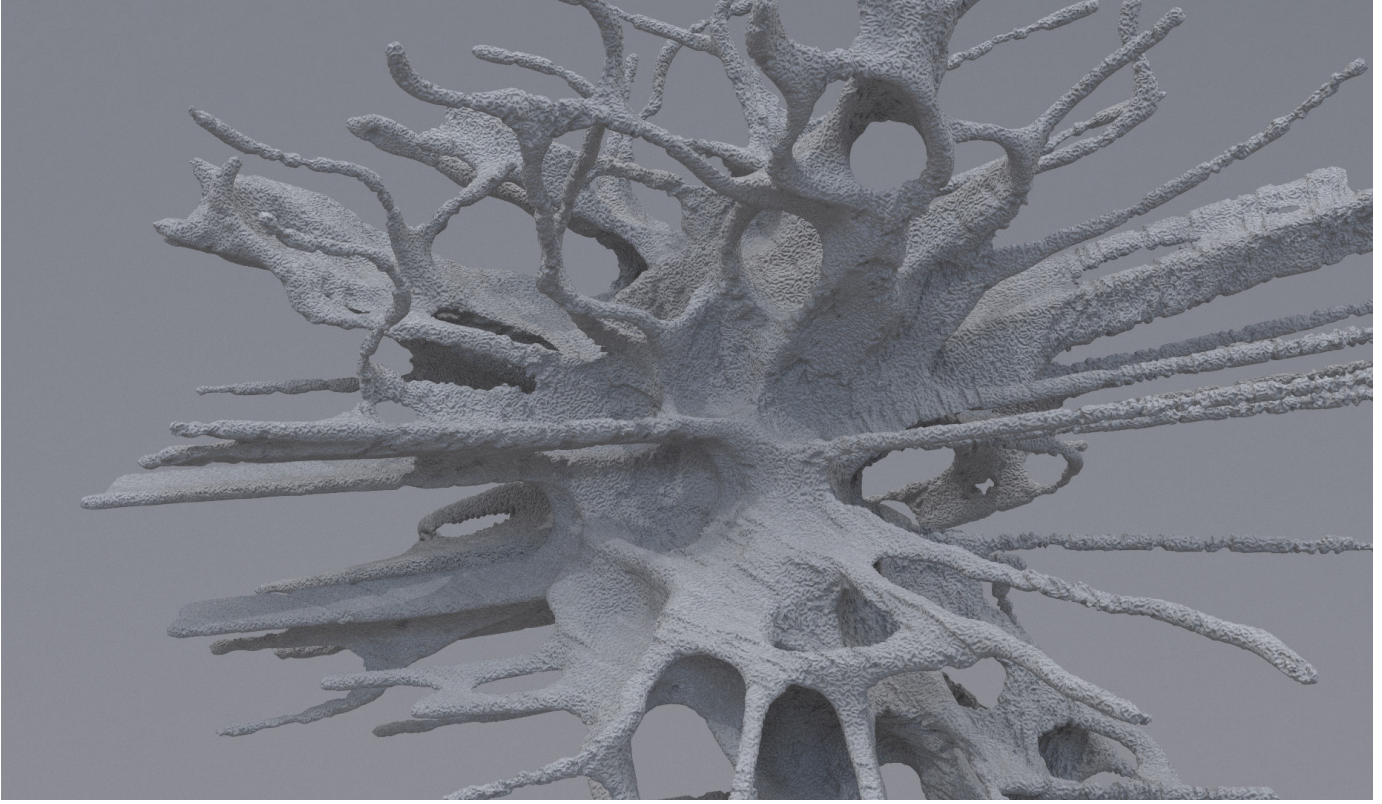



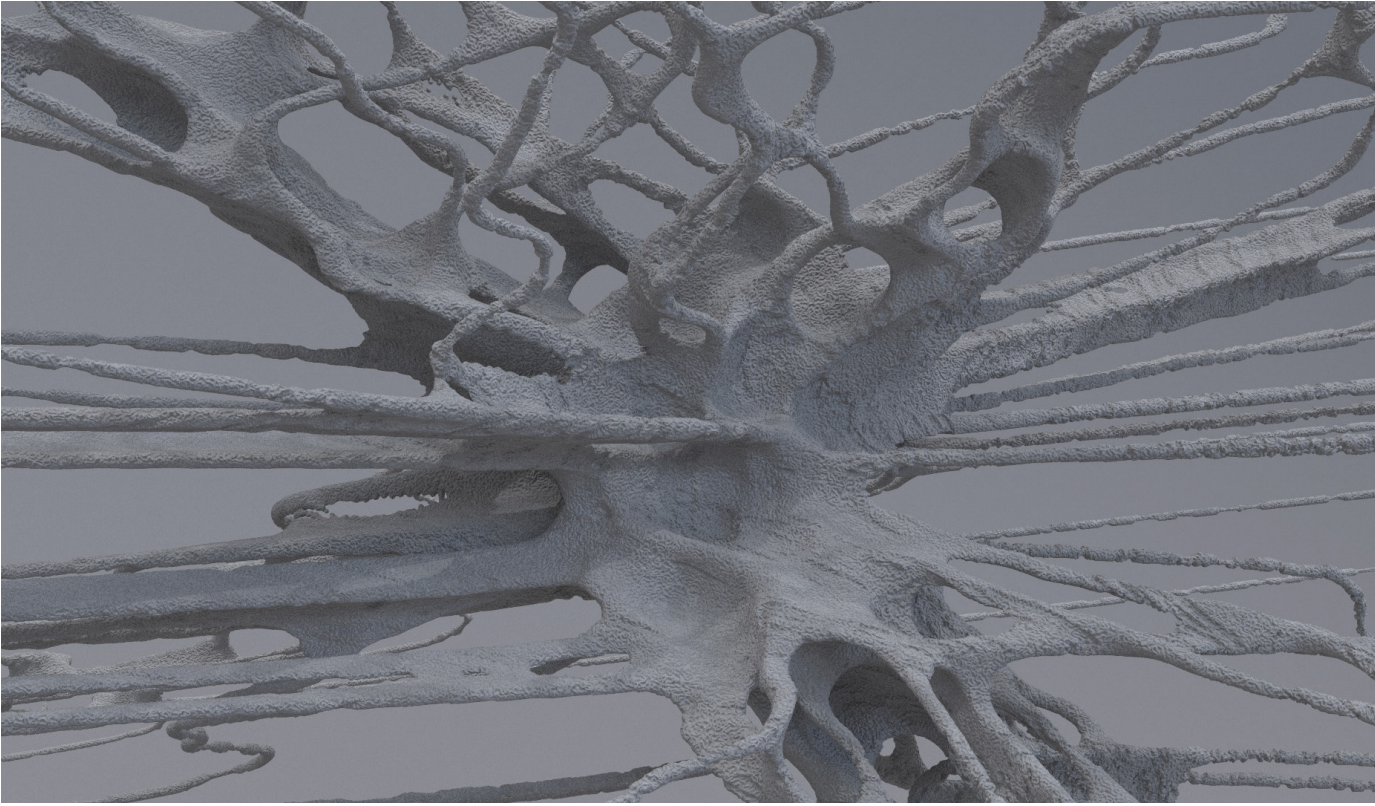
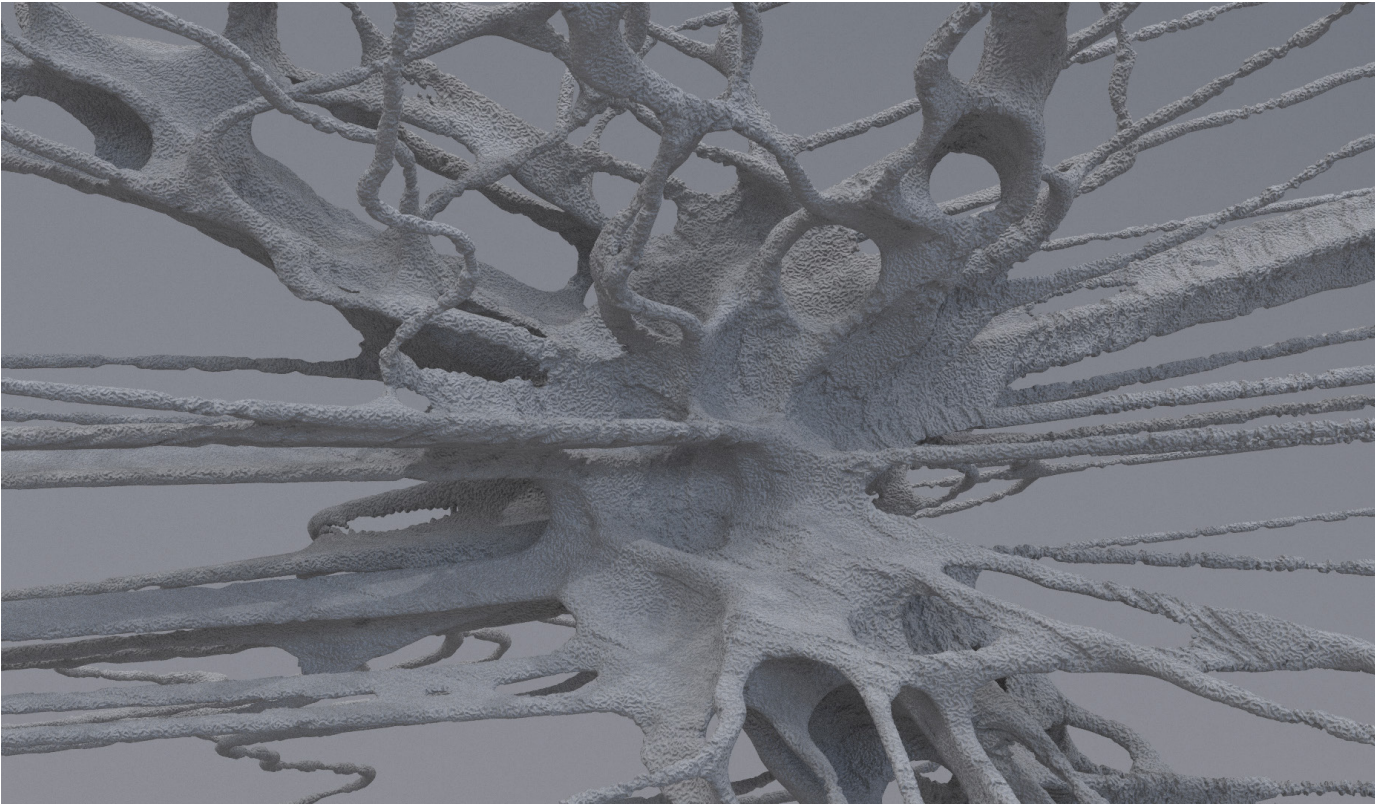



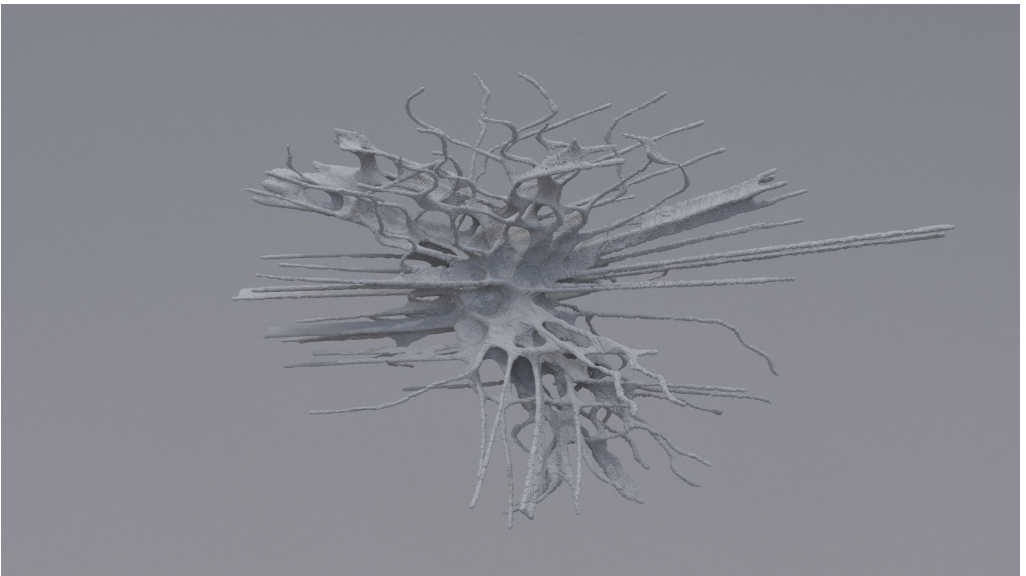
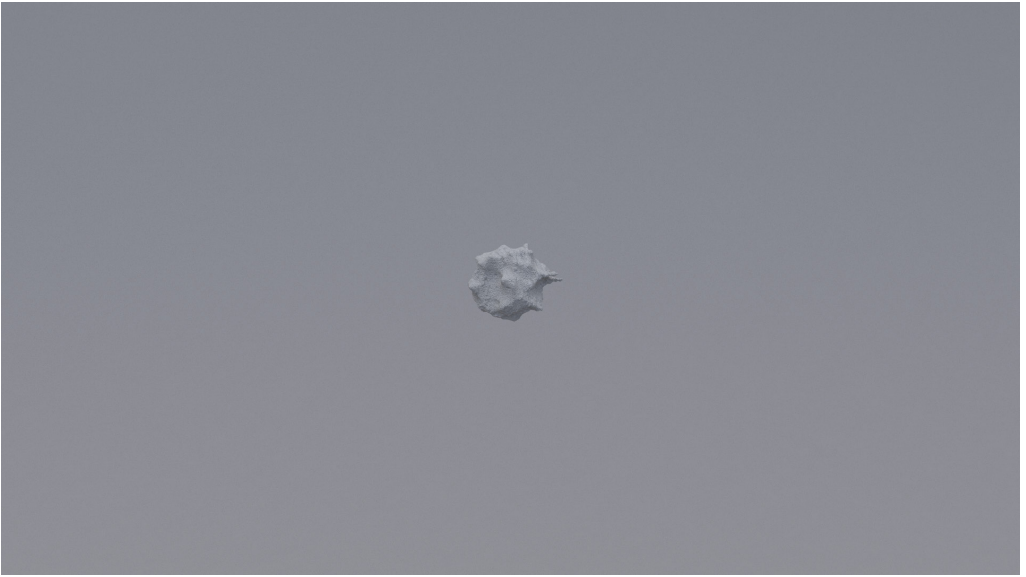

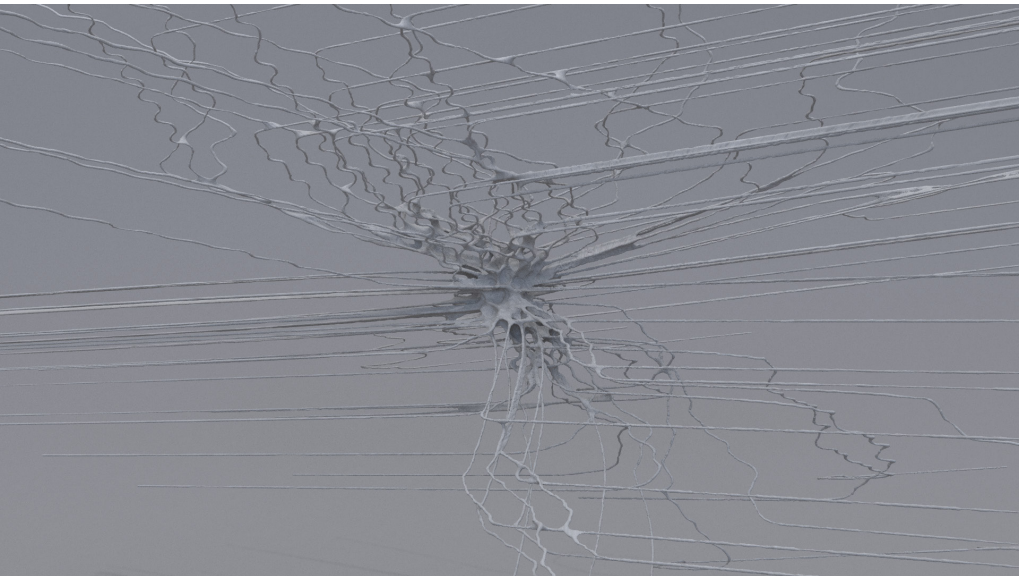
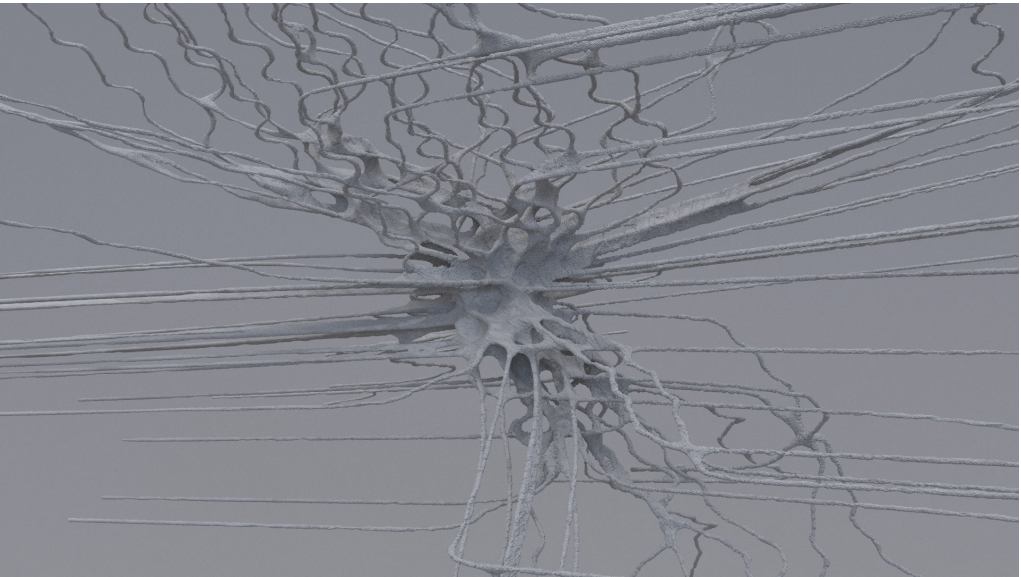
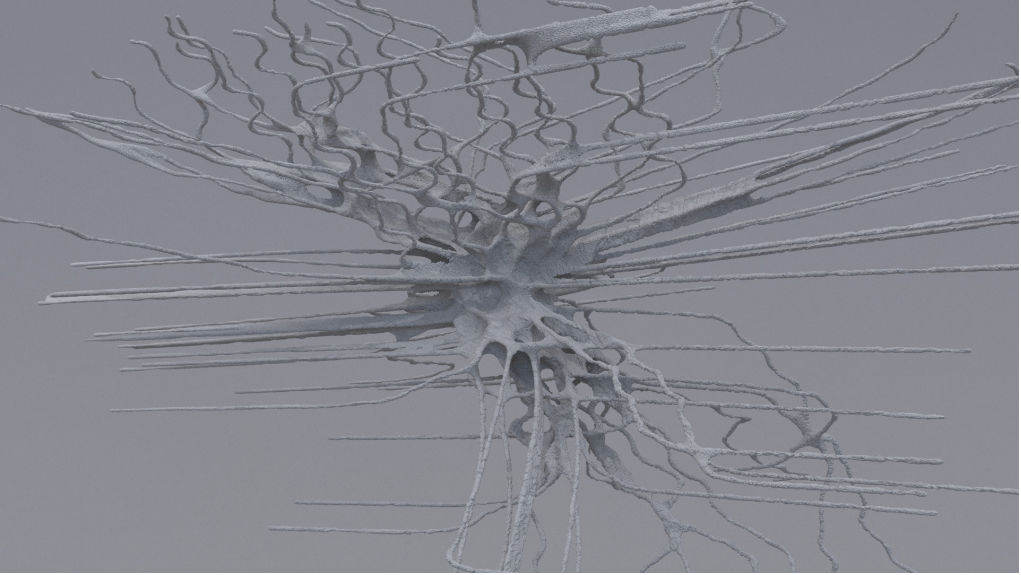





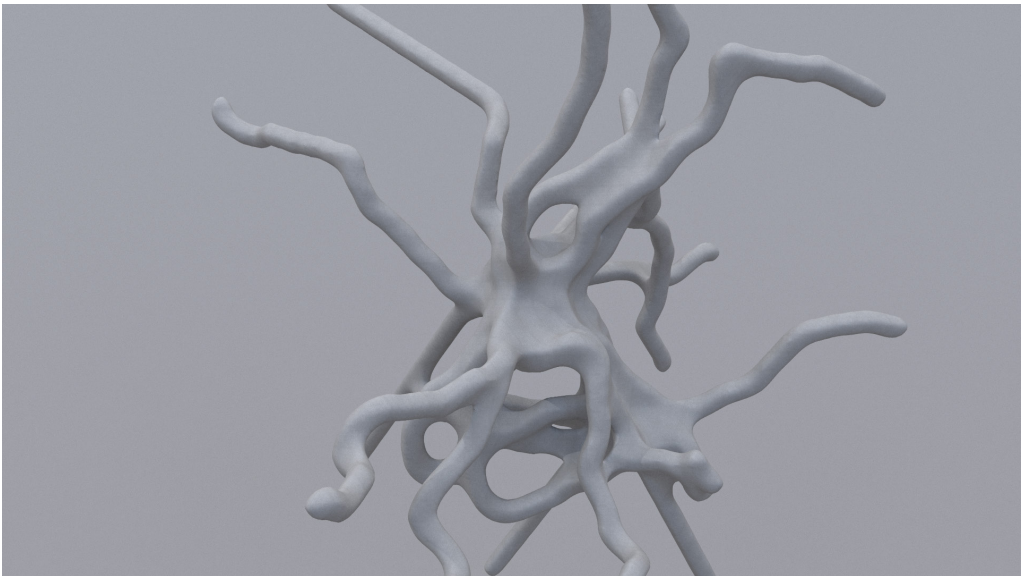
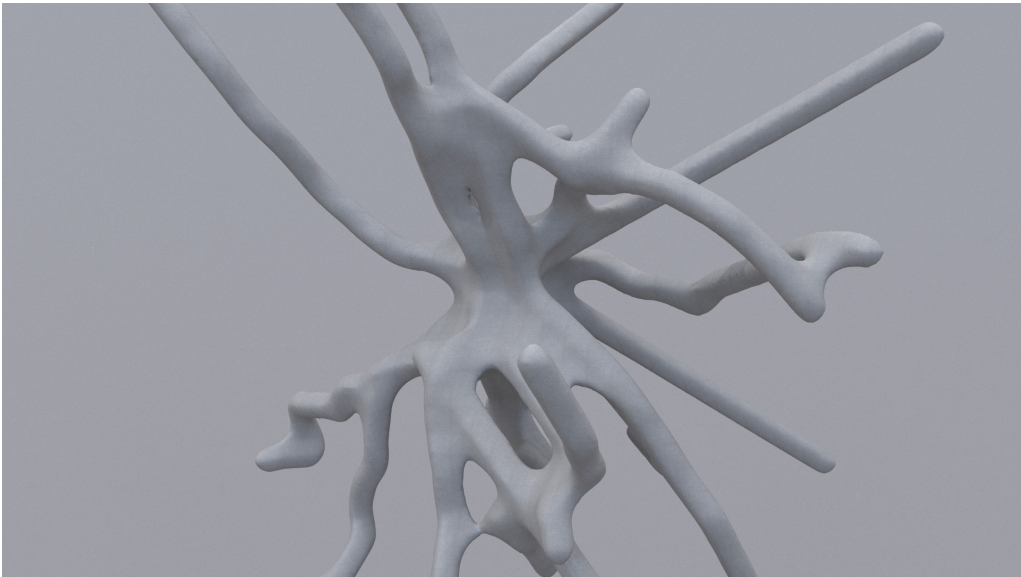



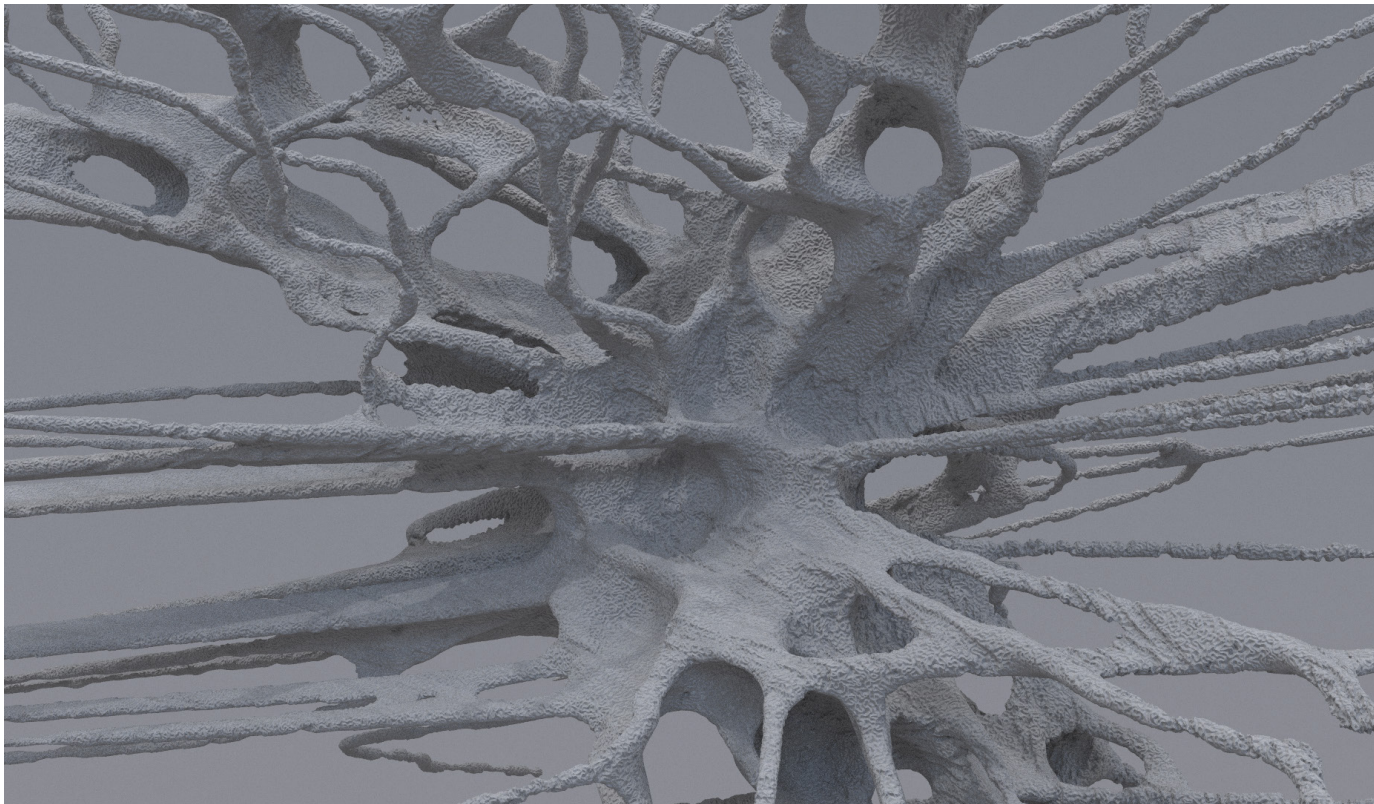
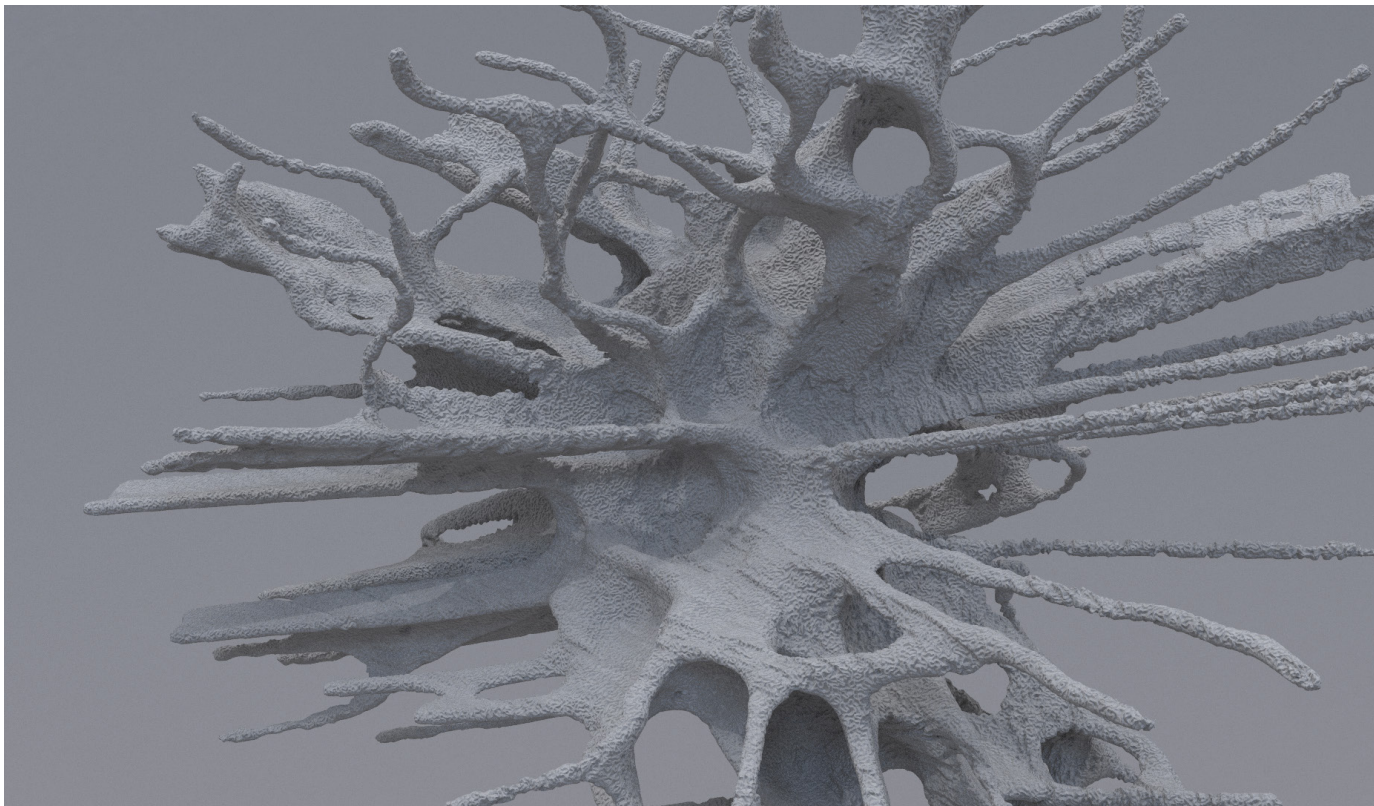



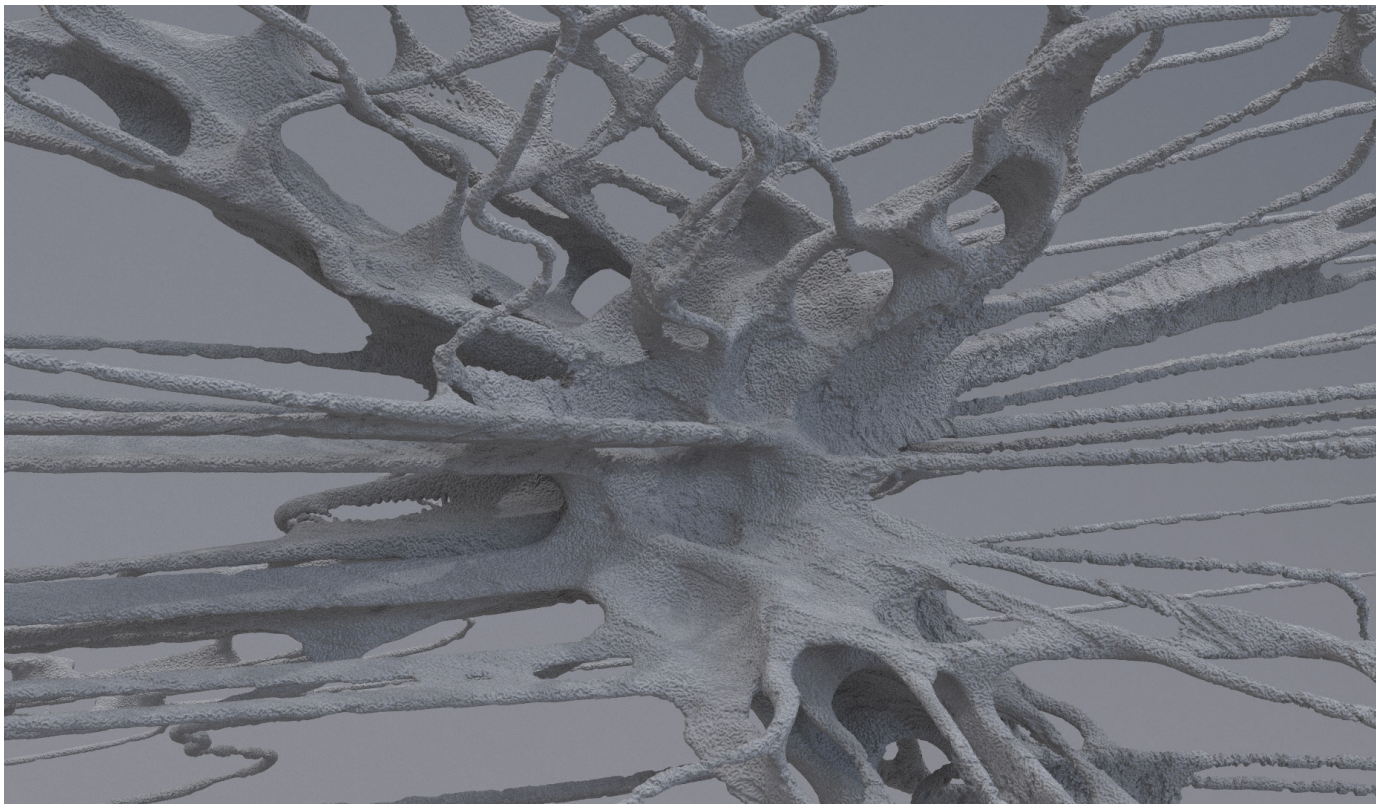
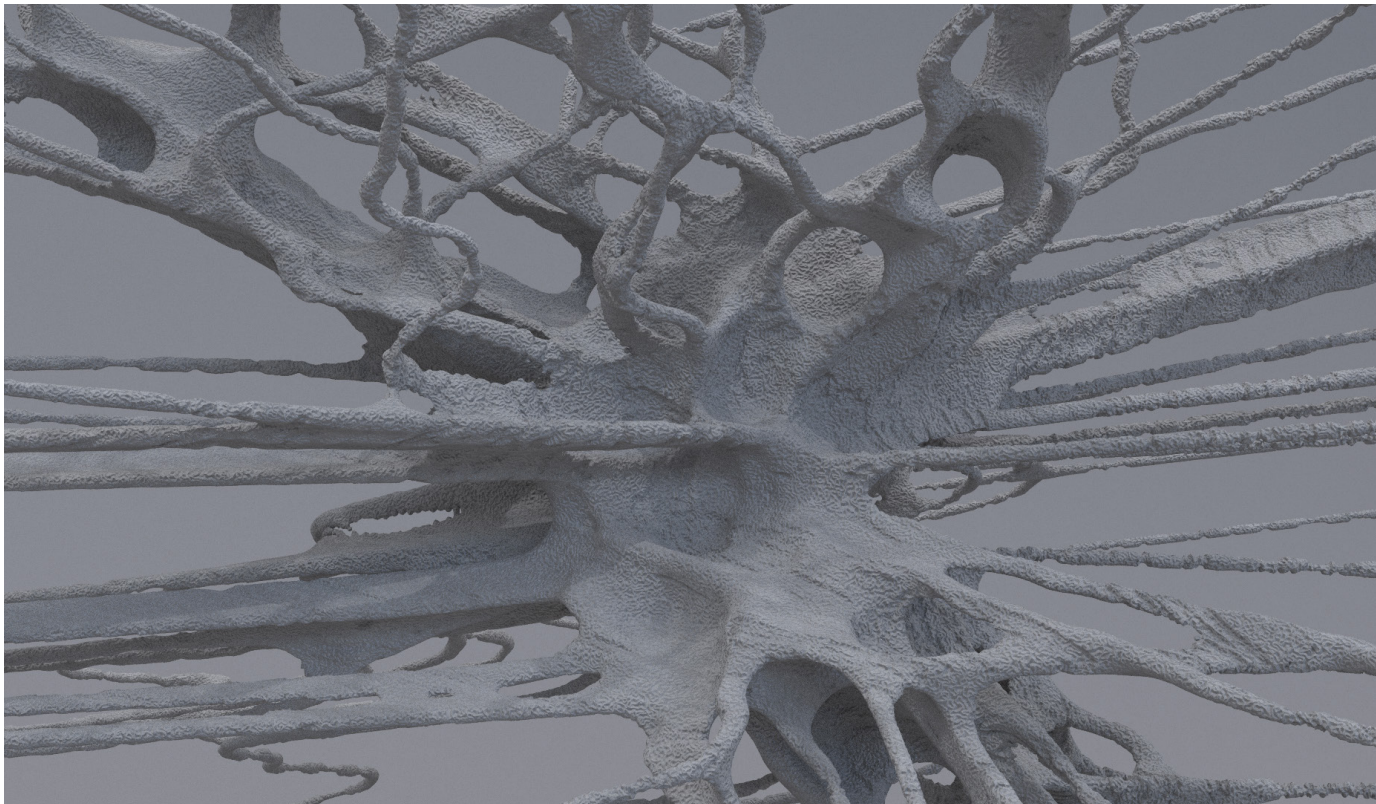

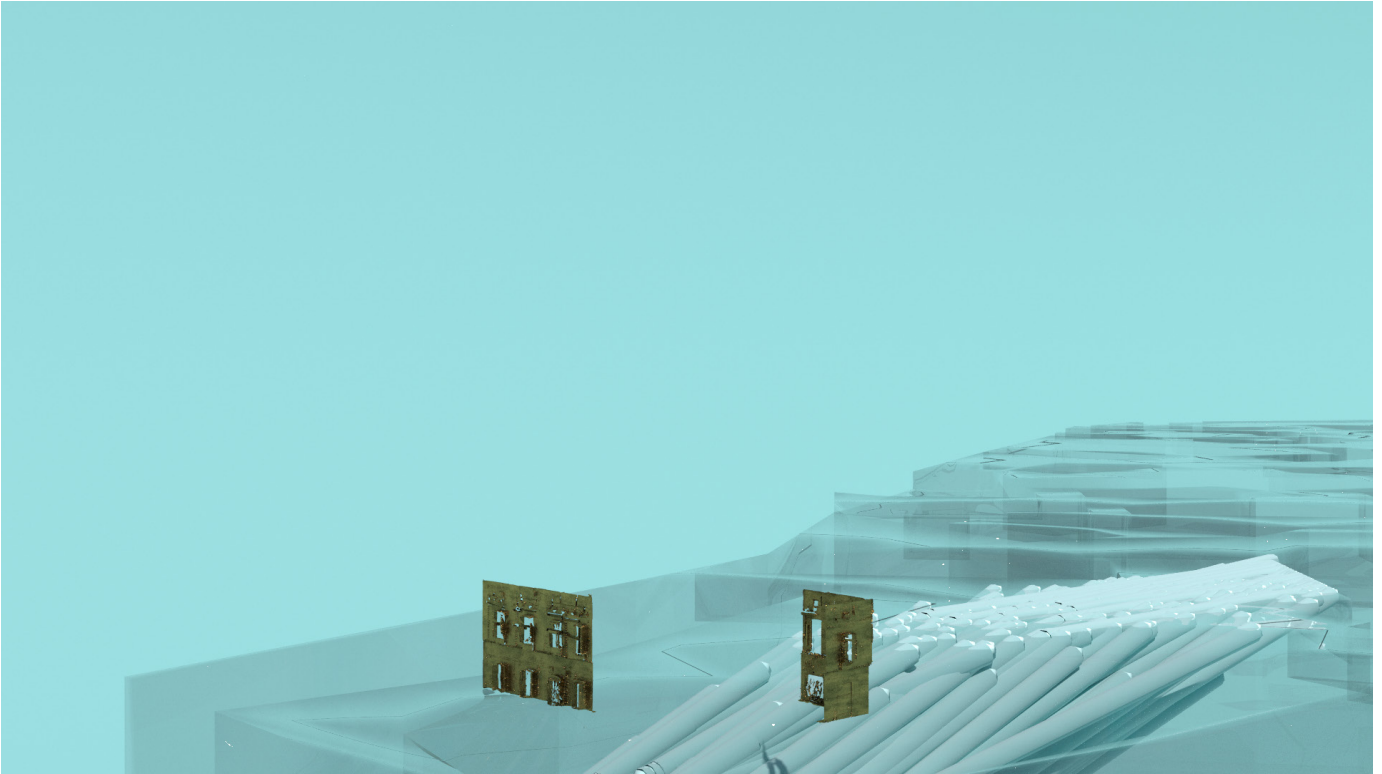
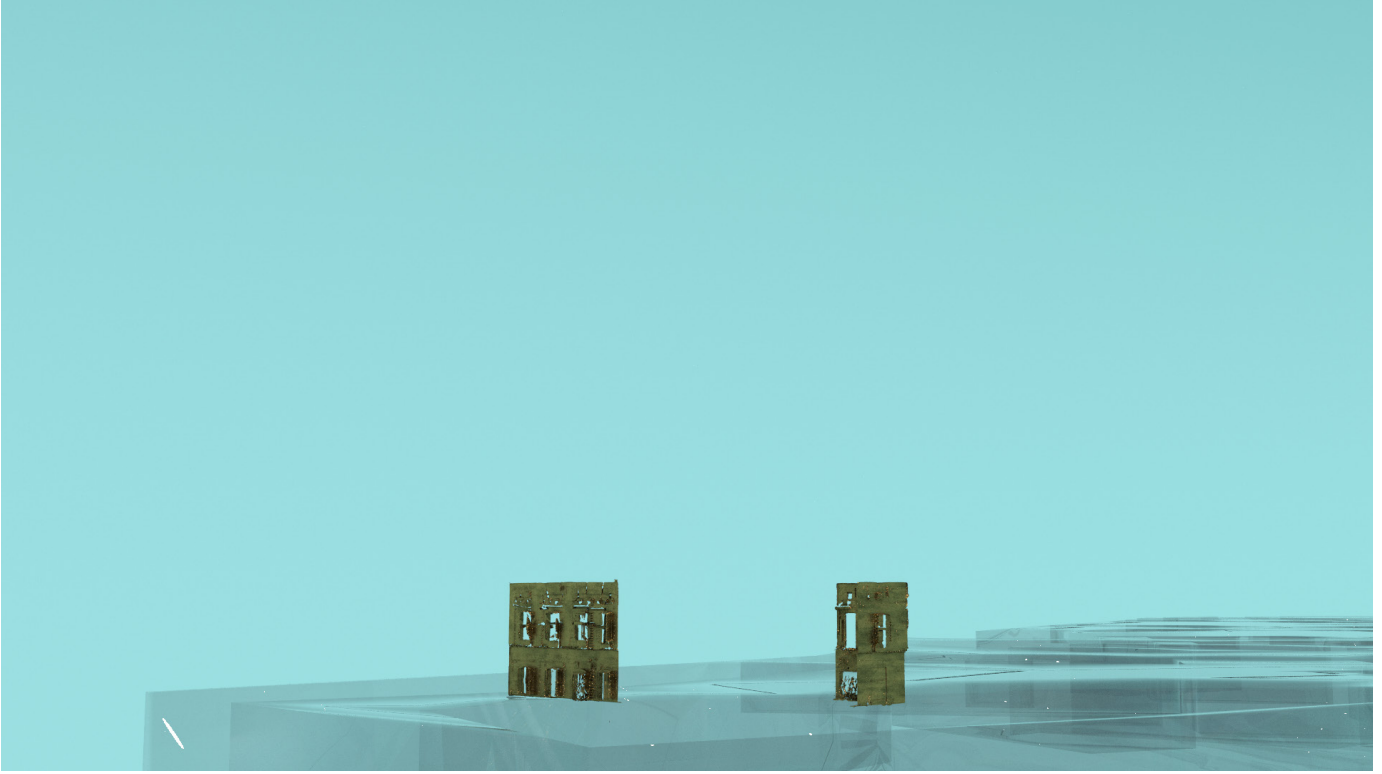



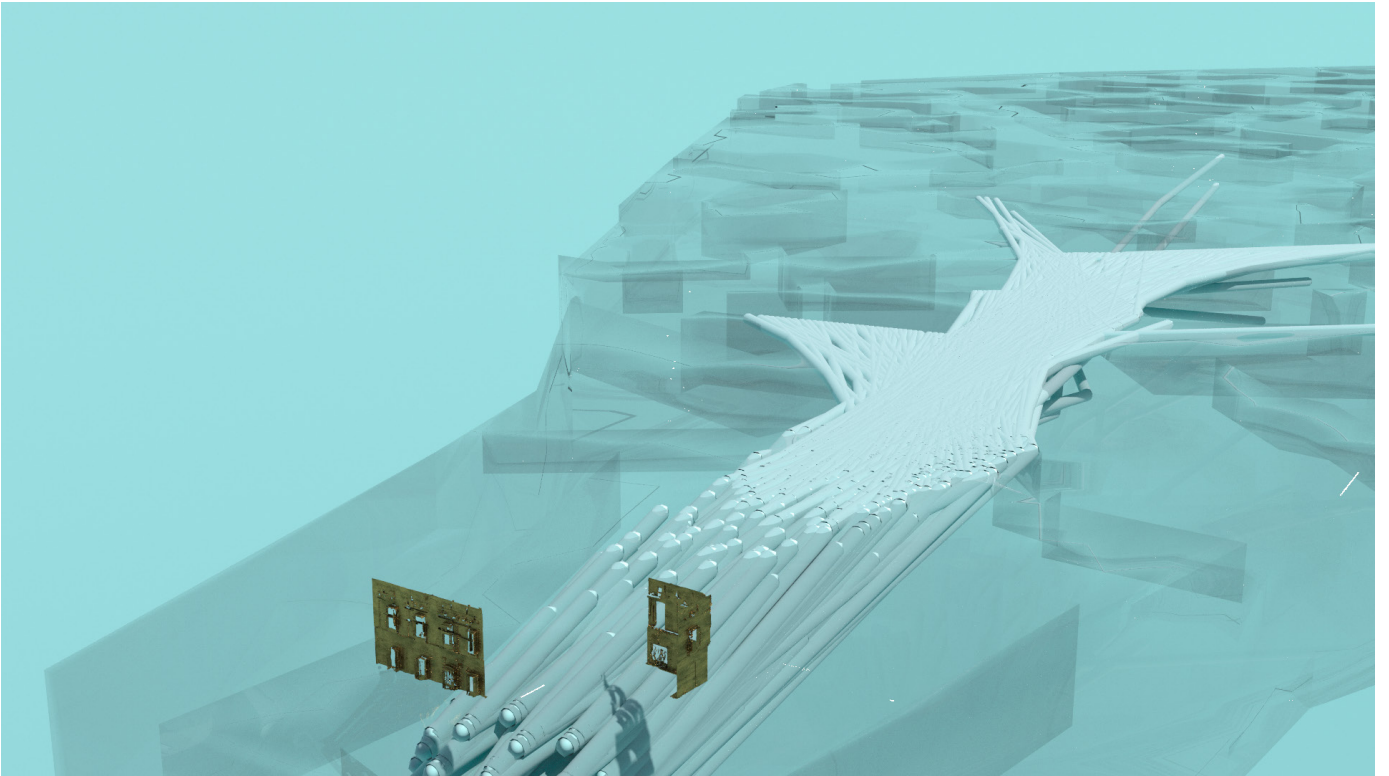
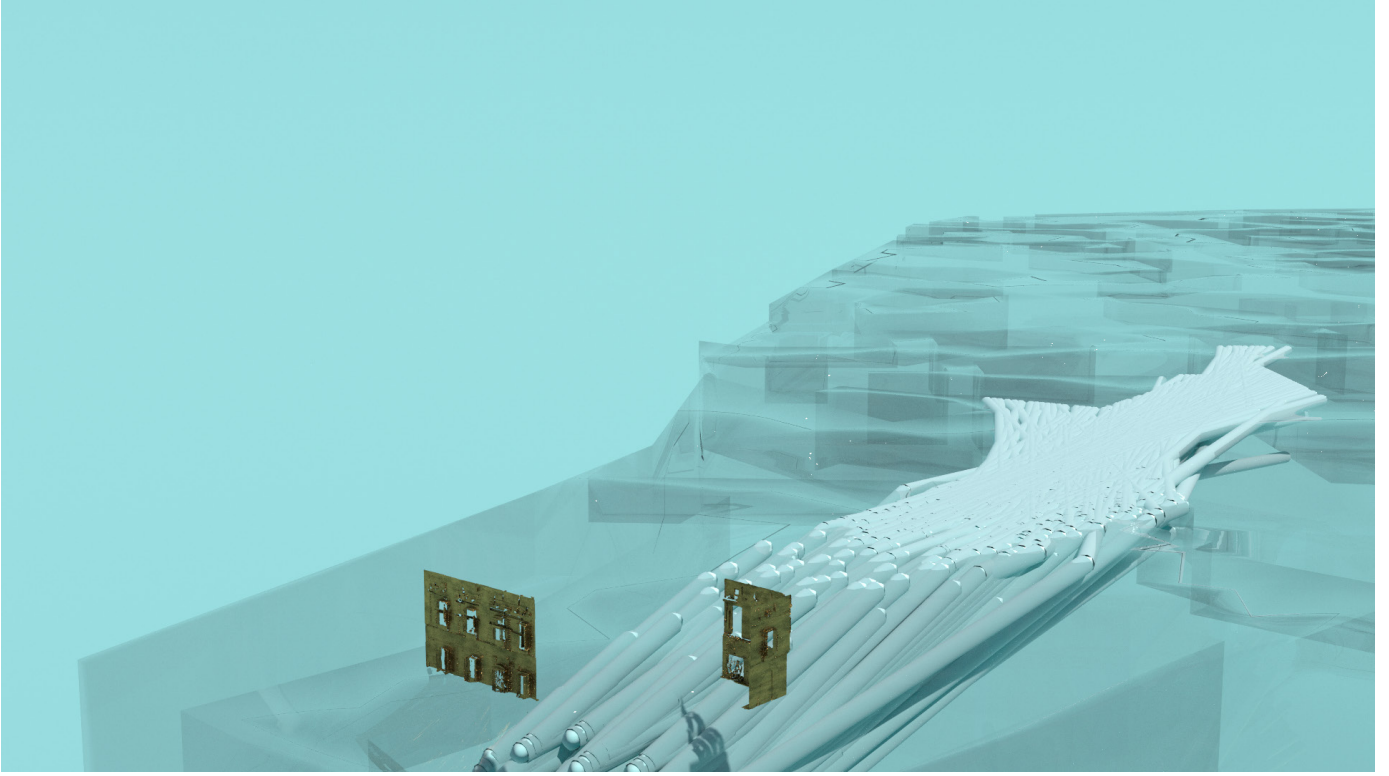



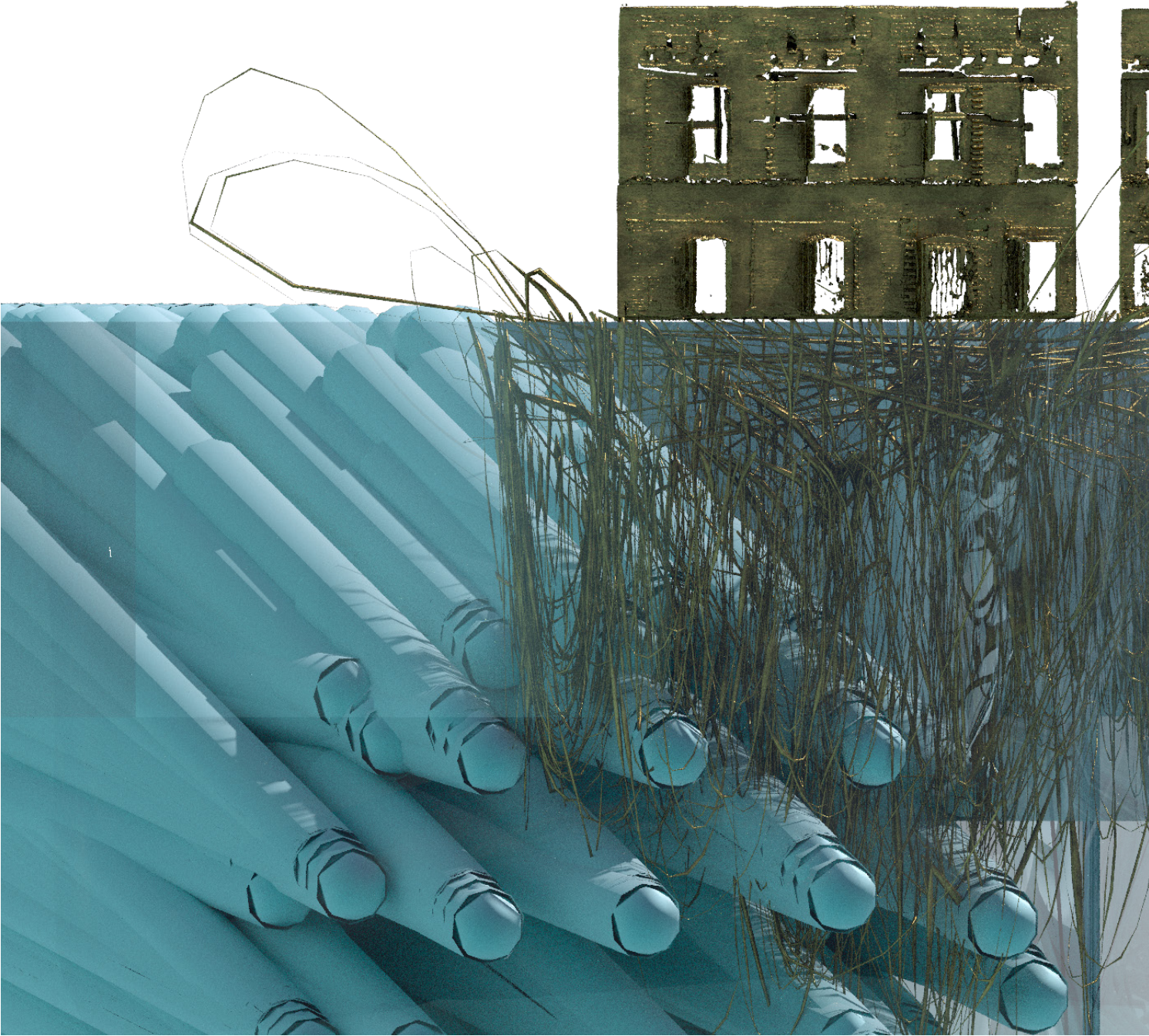





**Sign exist but signified doesn't.  
Battle of structuralists and post-structura-  
lists.**





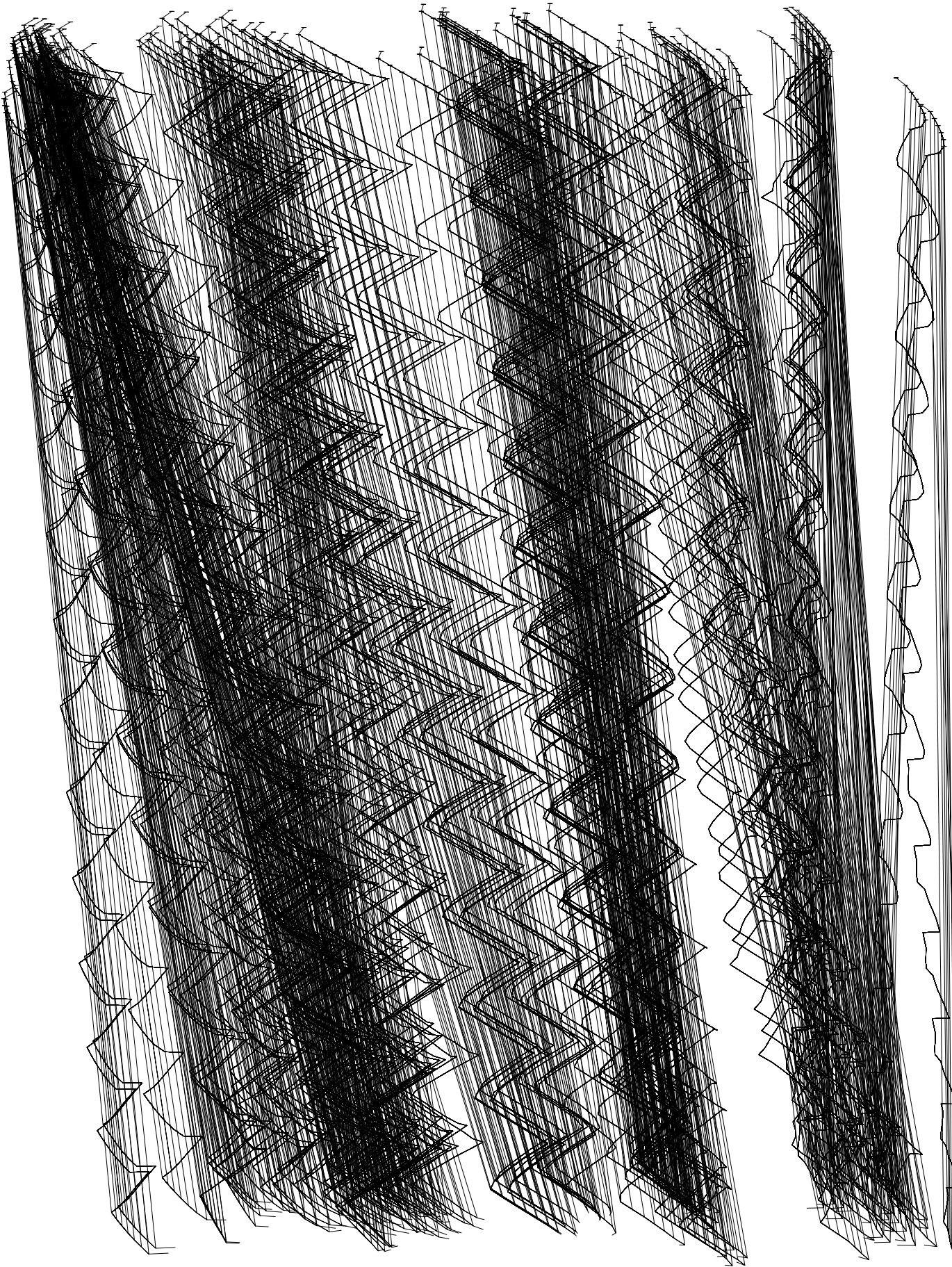

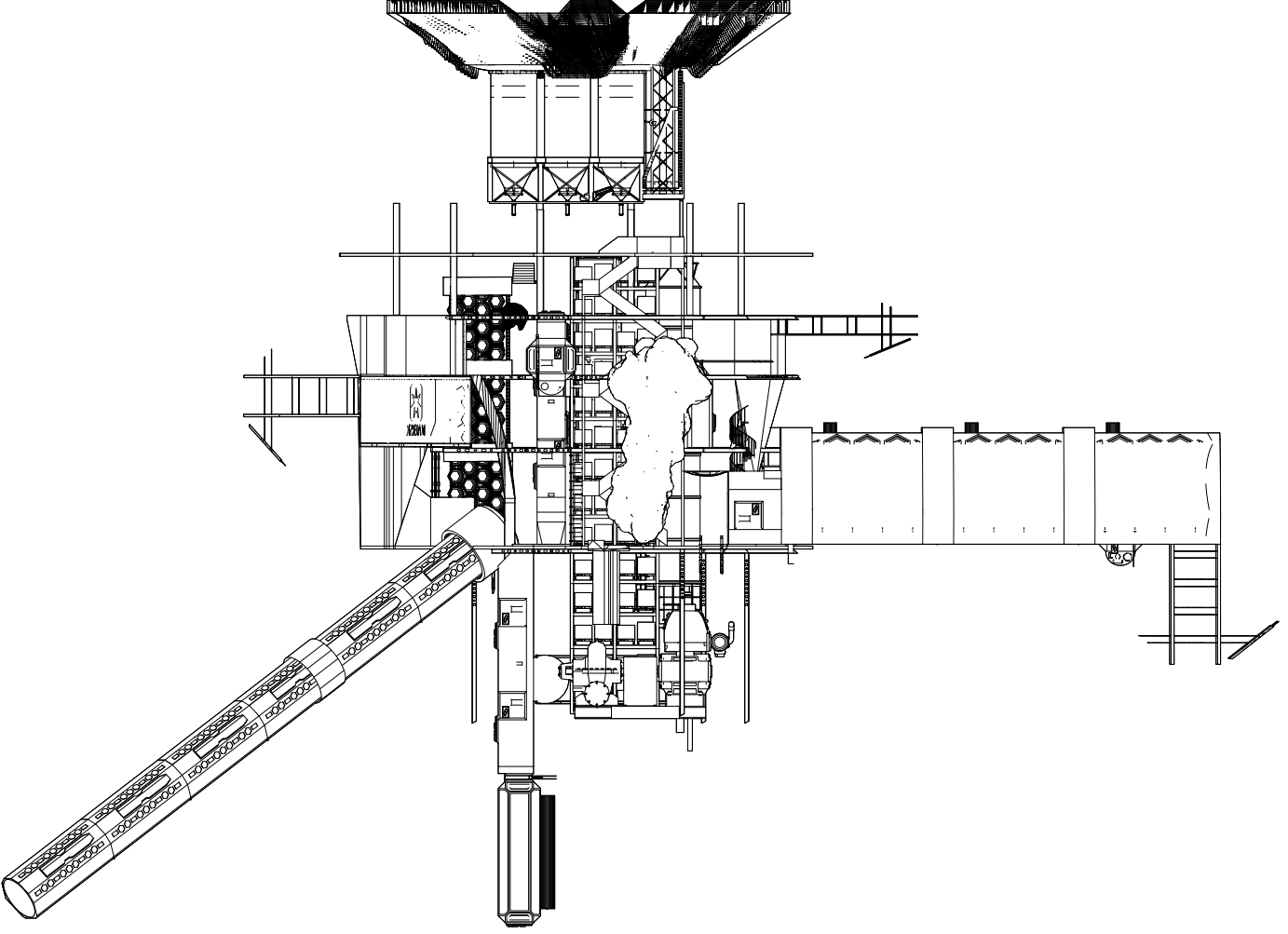



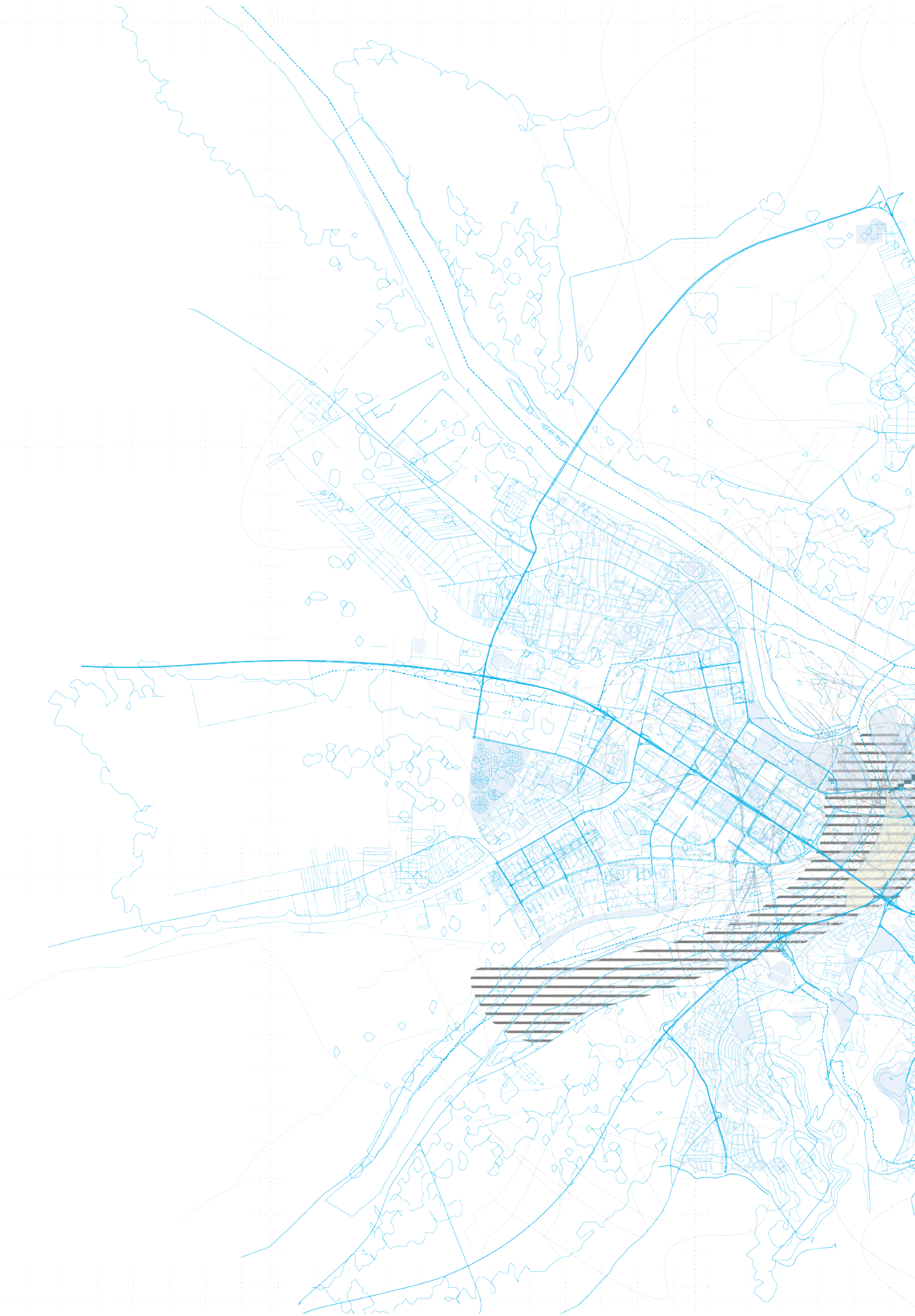



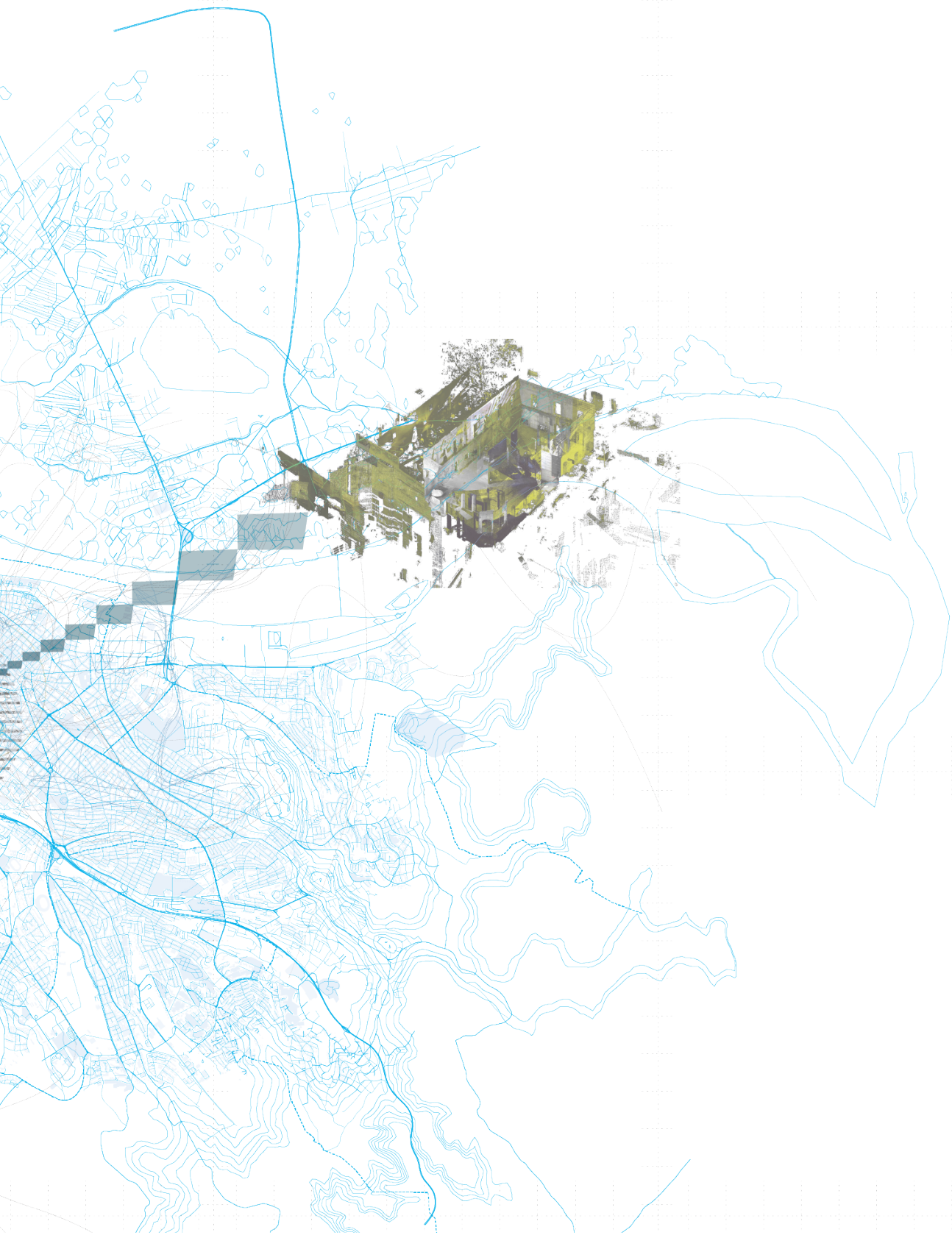

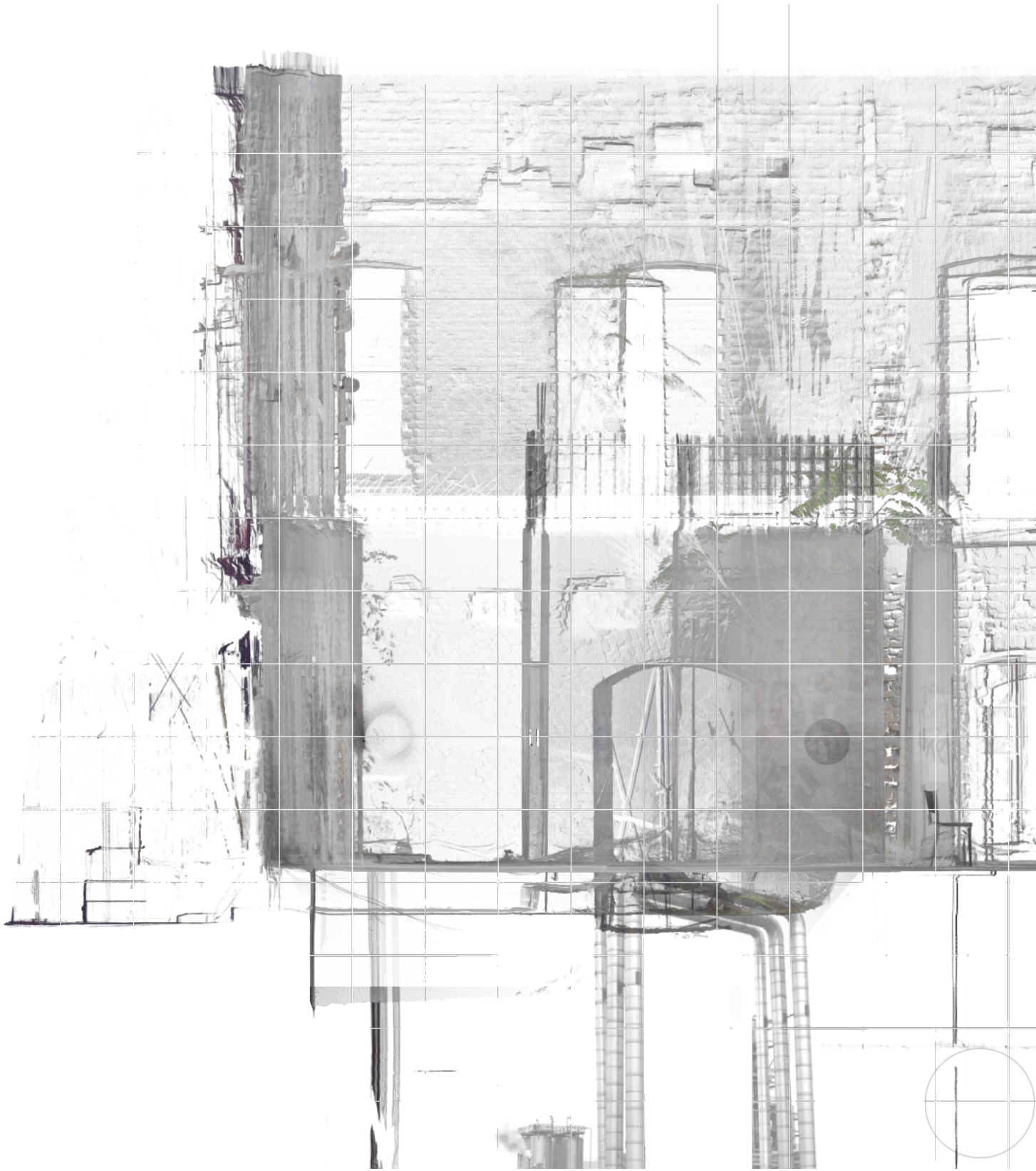



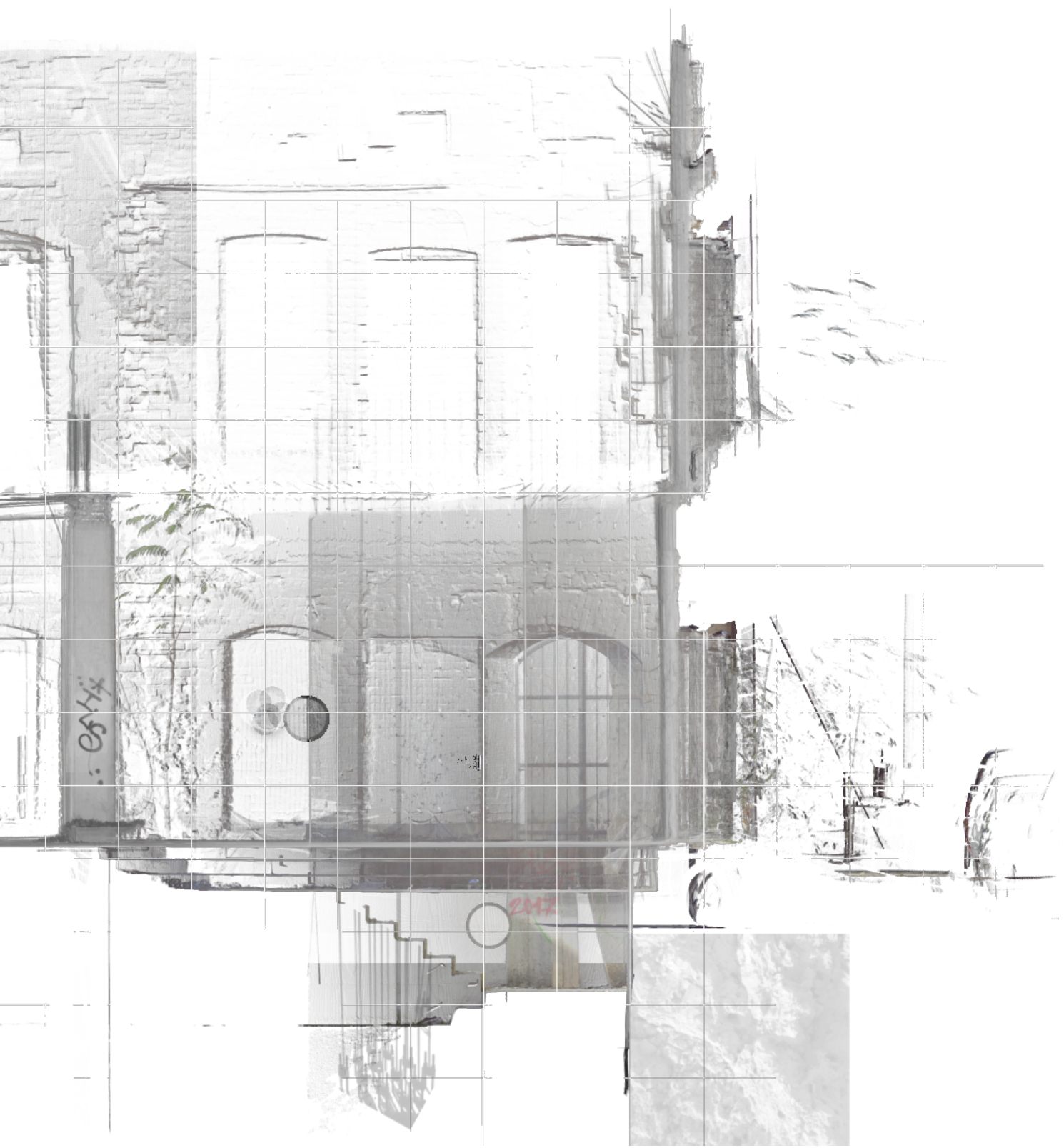







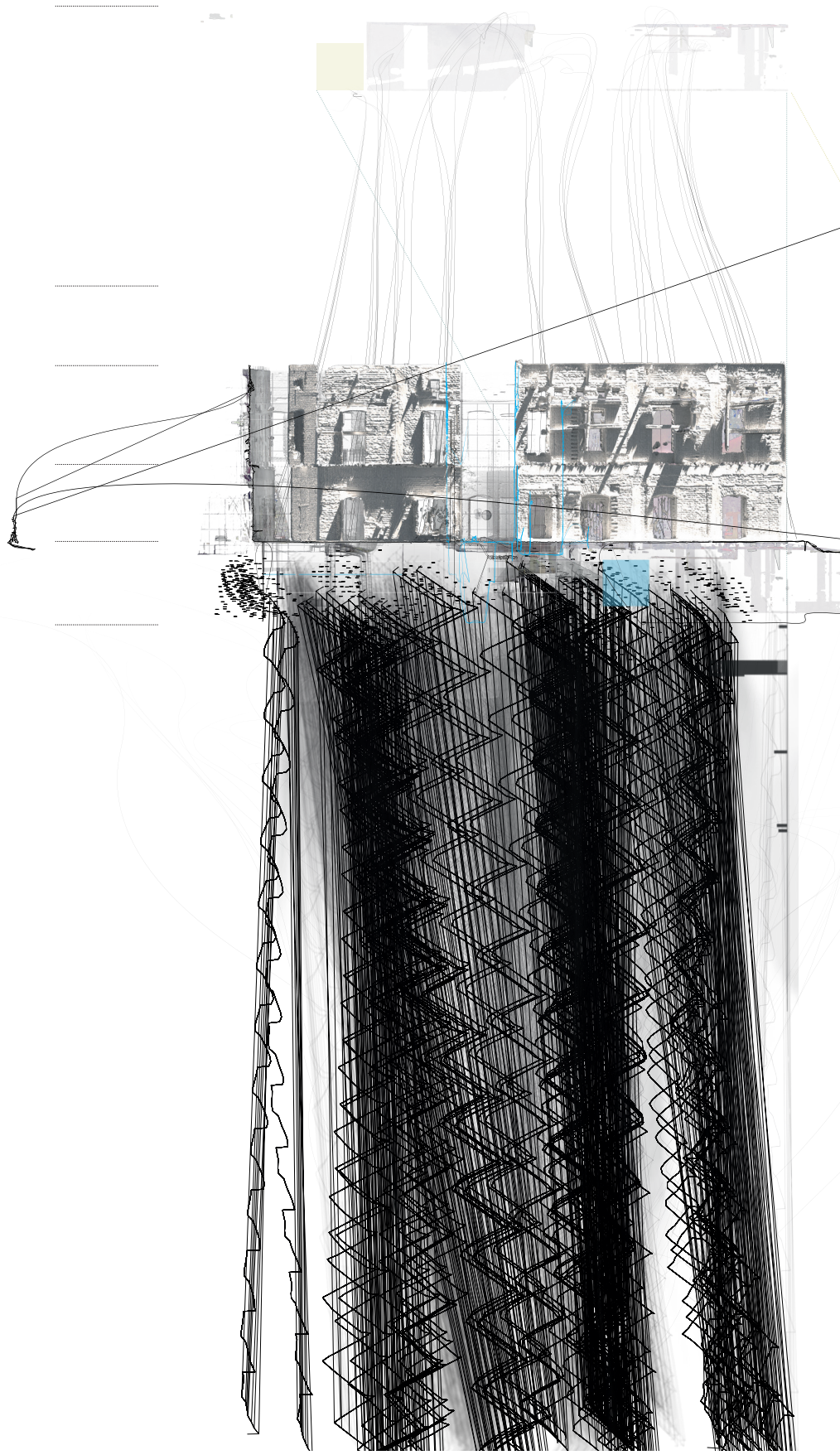

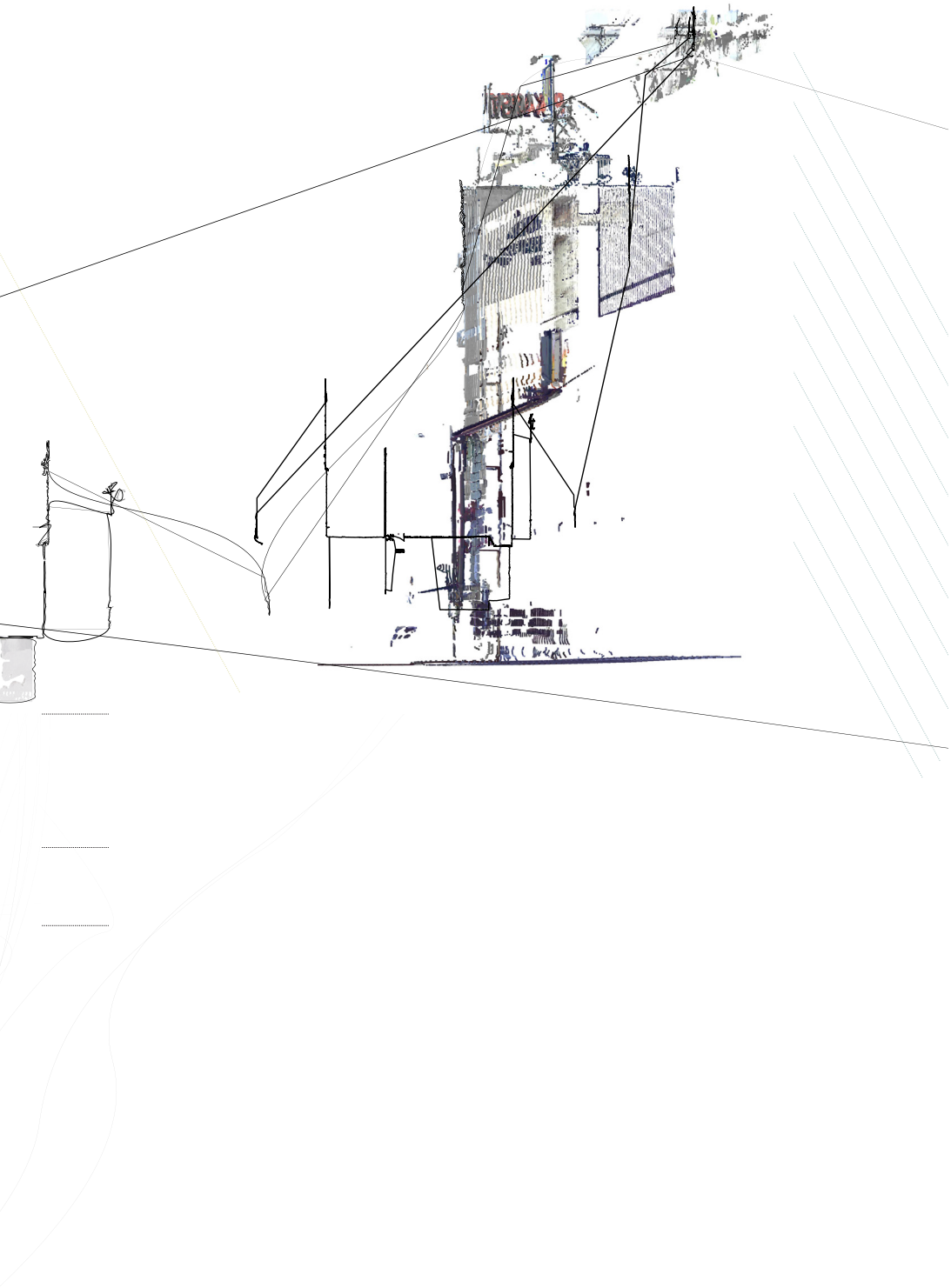

Parasite-sabotage from within not protest on the street (old instrument) as in black mirror...  
Political structure has its instruments to prevent the old fashioned rebellion.





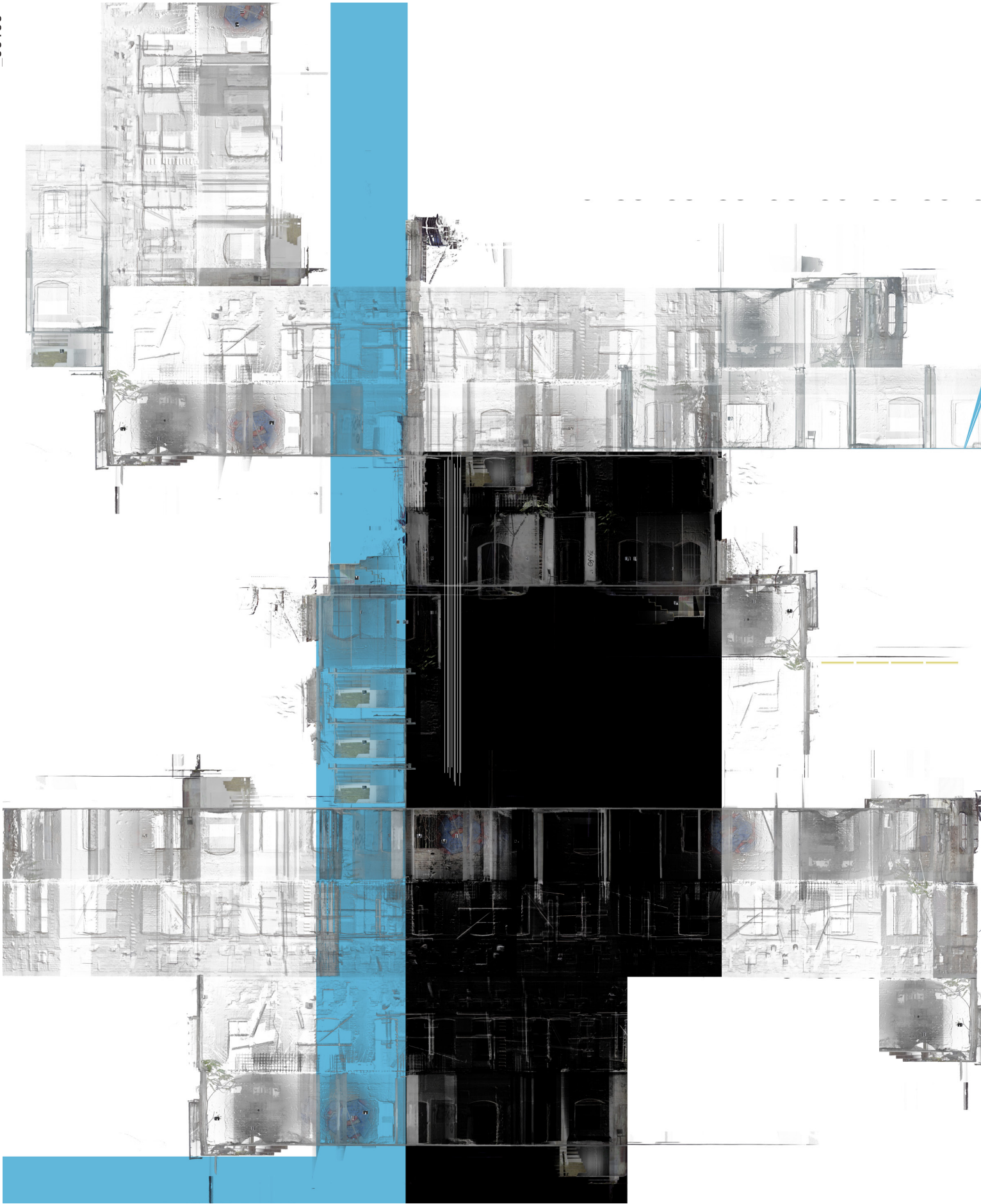



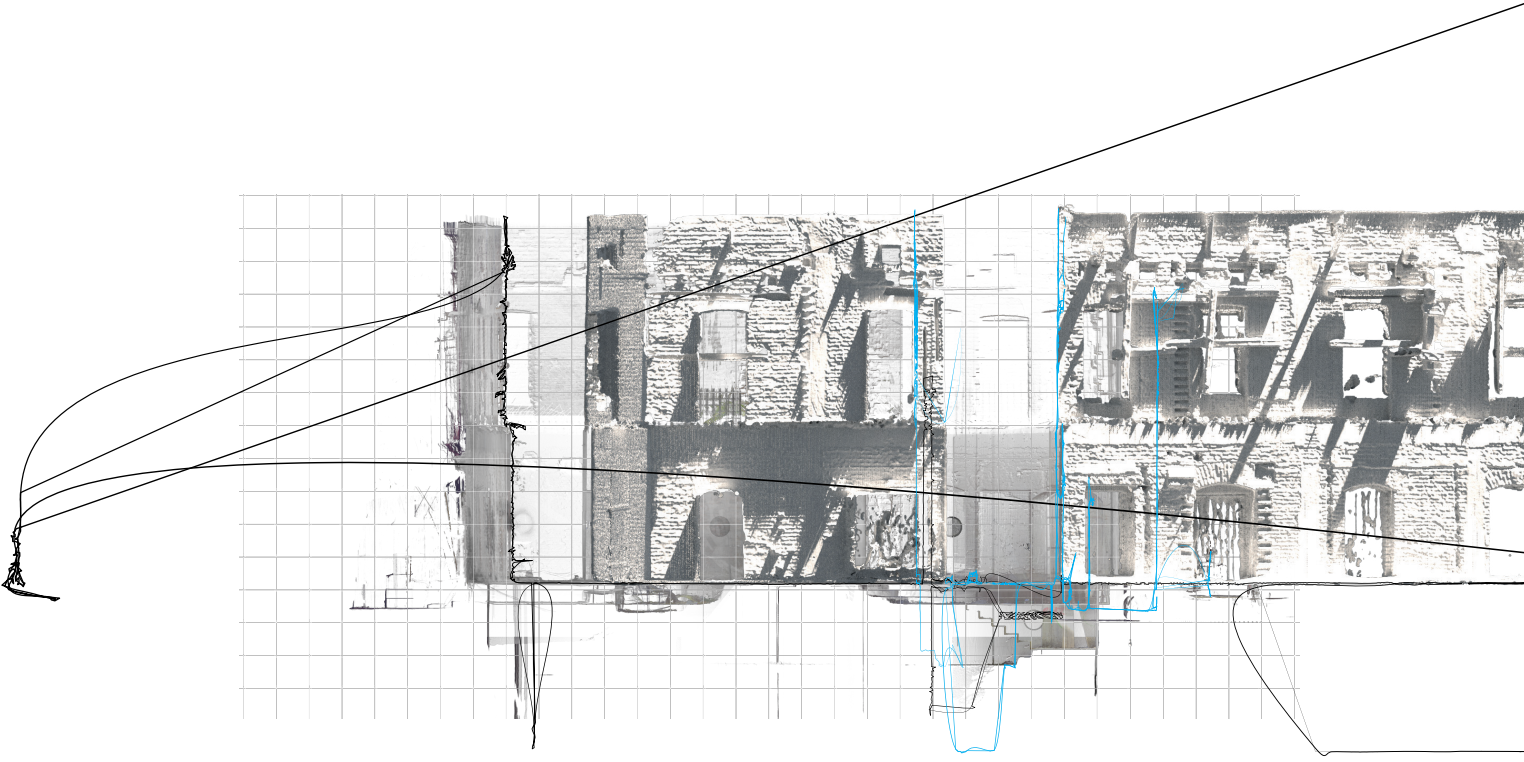



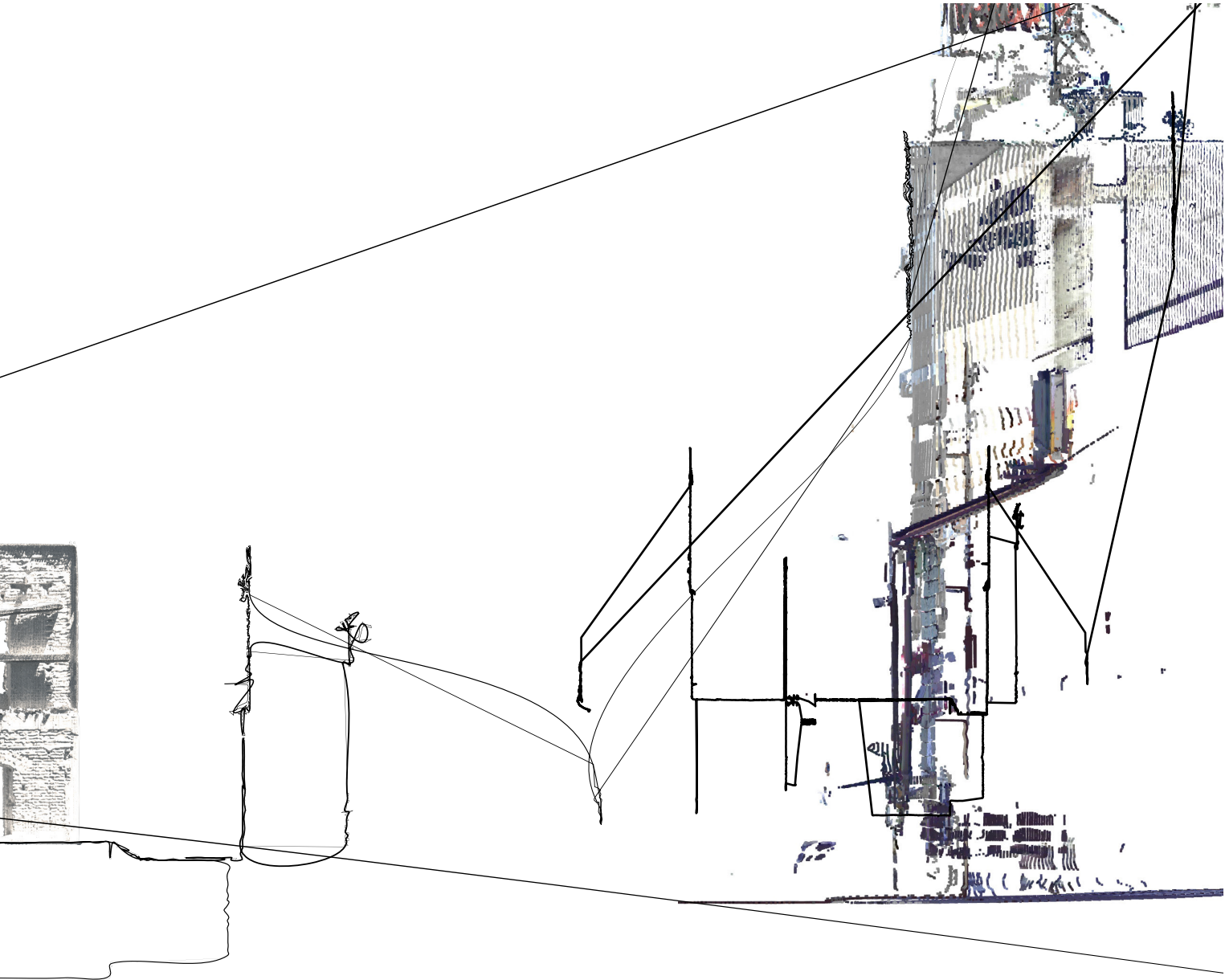

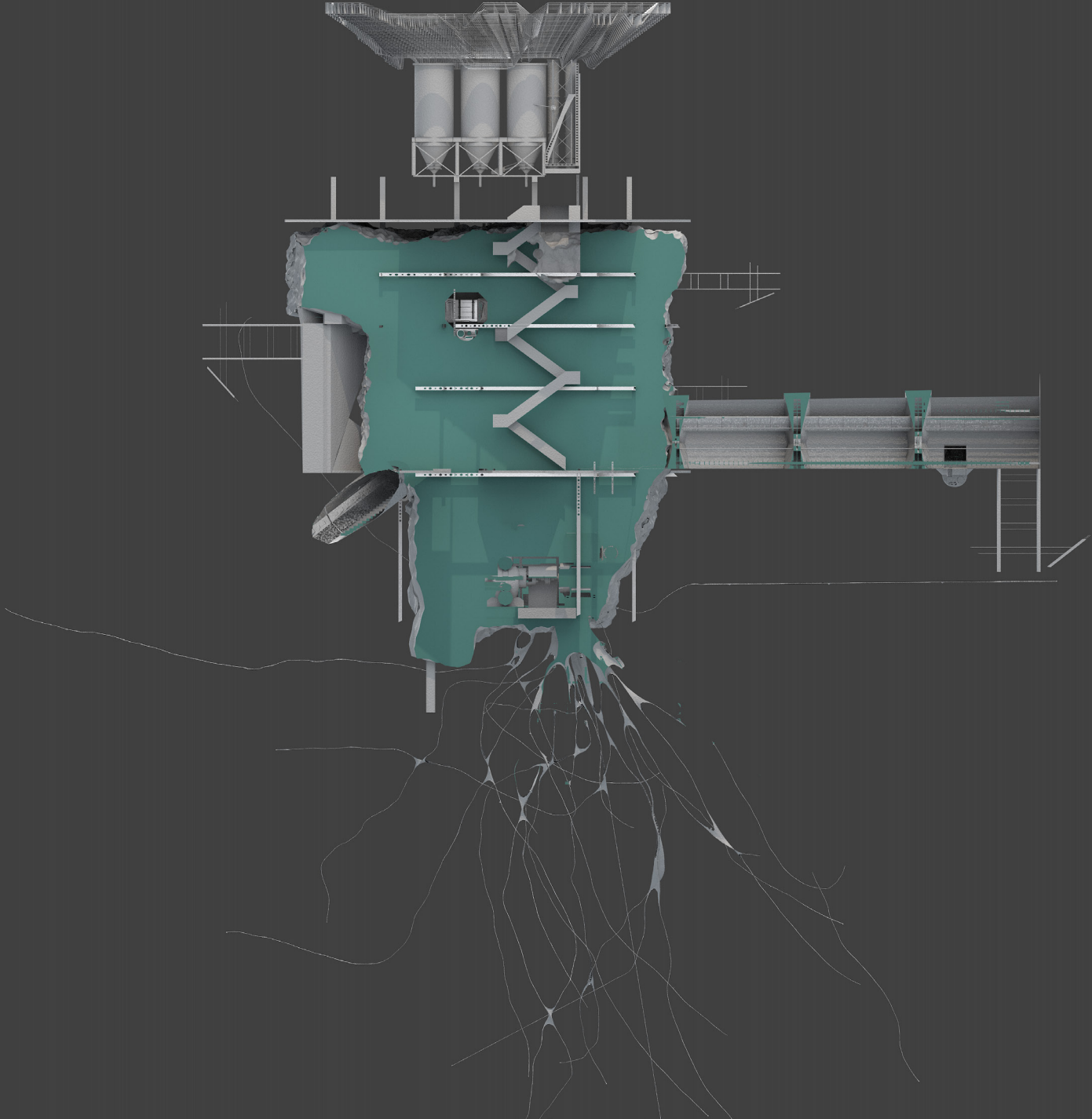

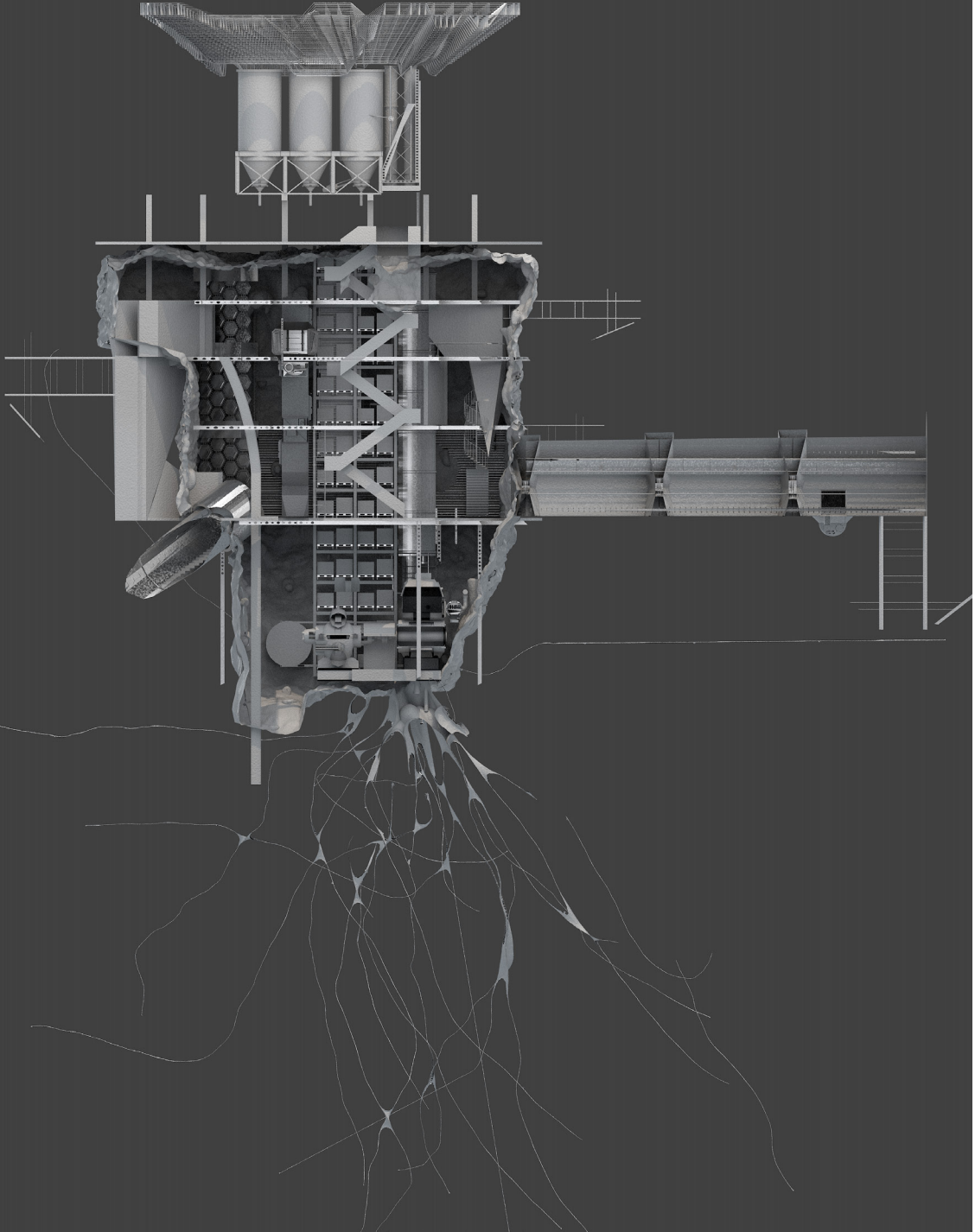



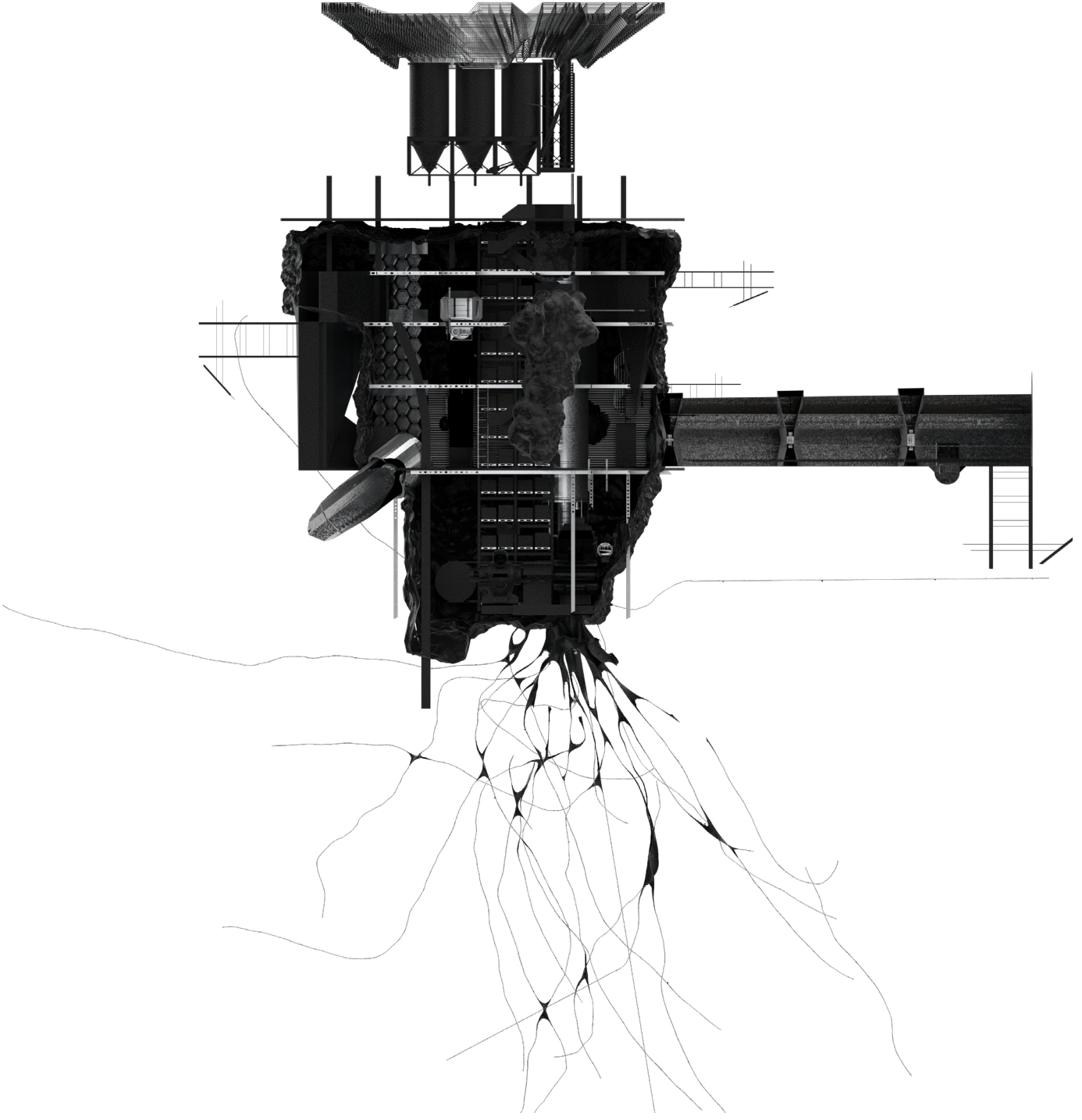







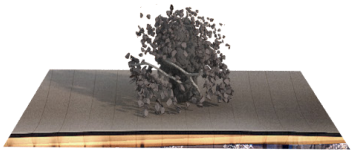

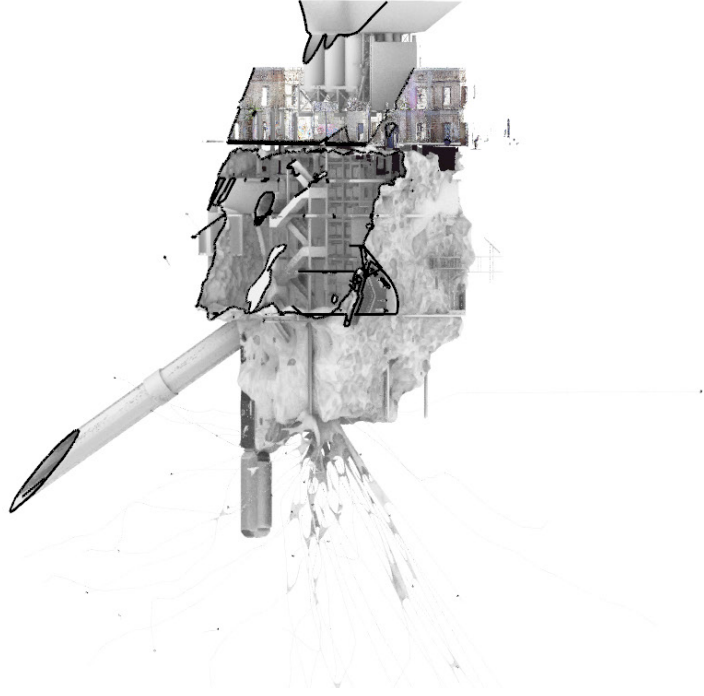

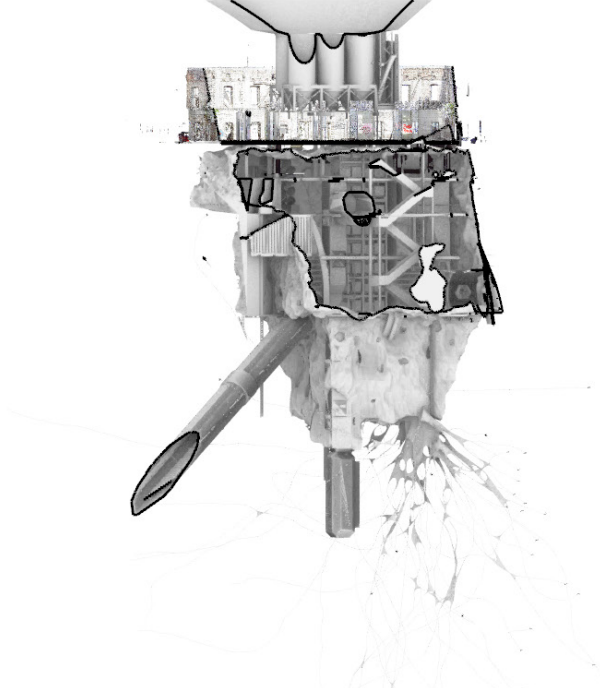

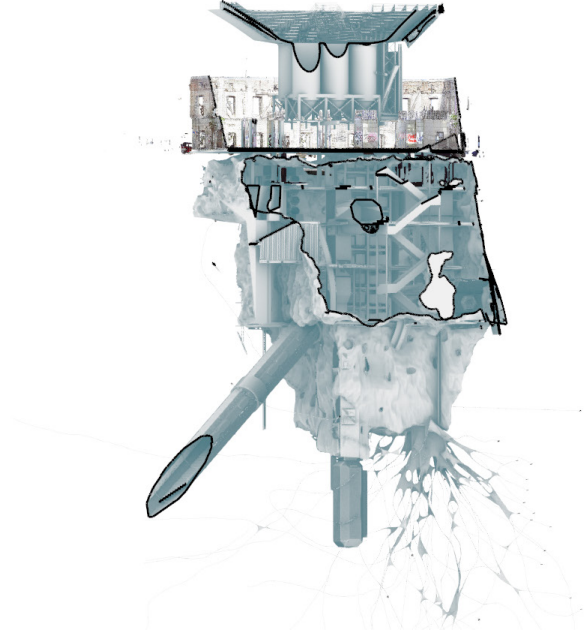
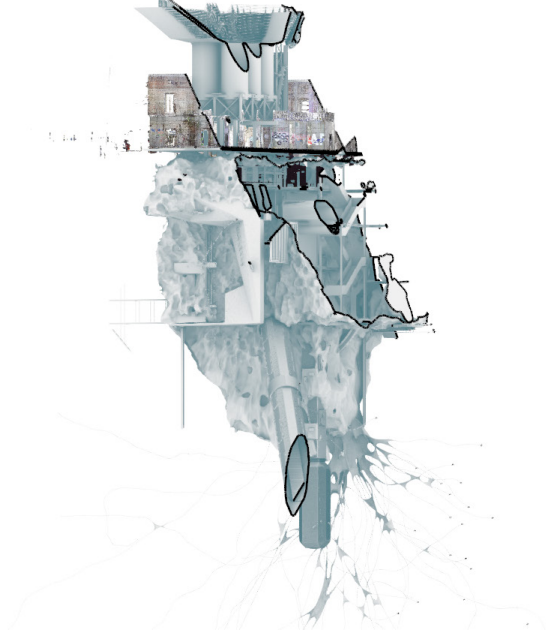



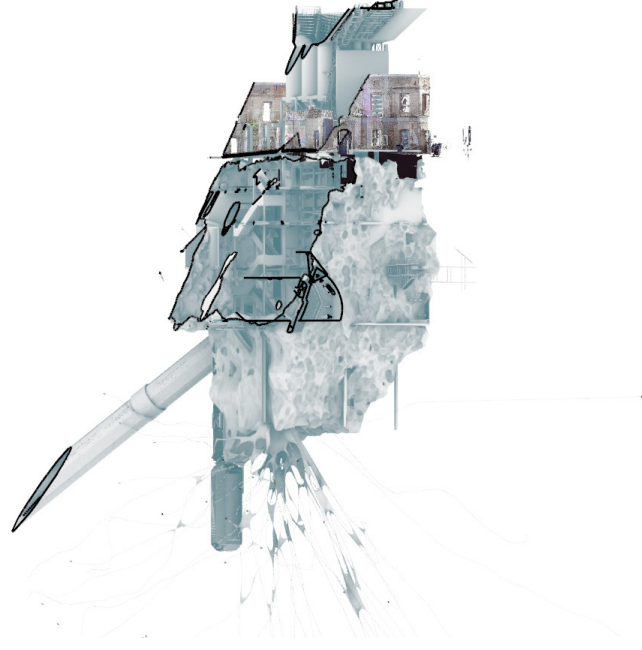
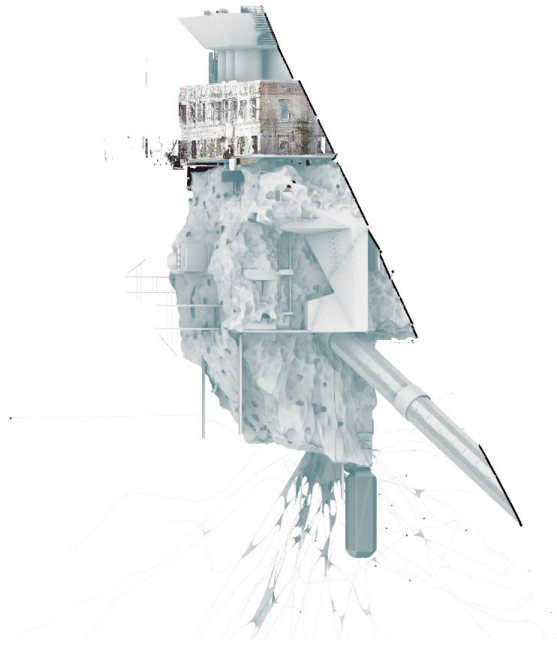

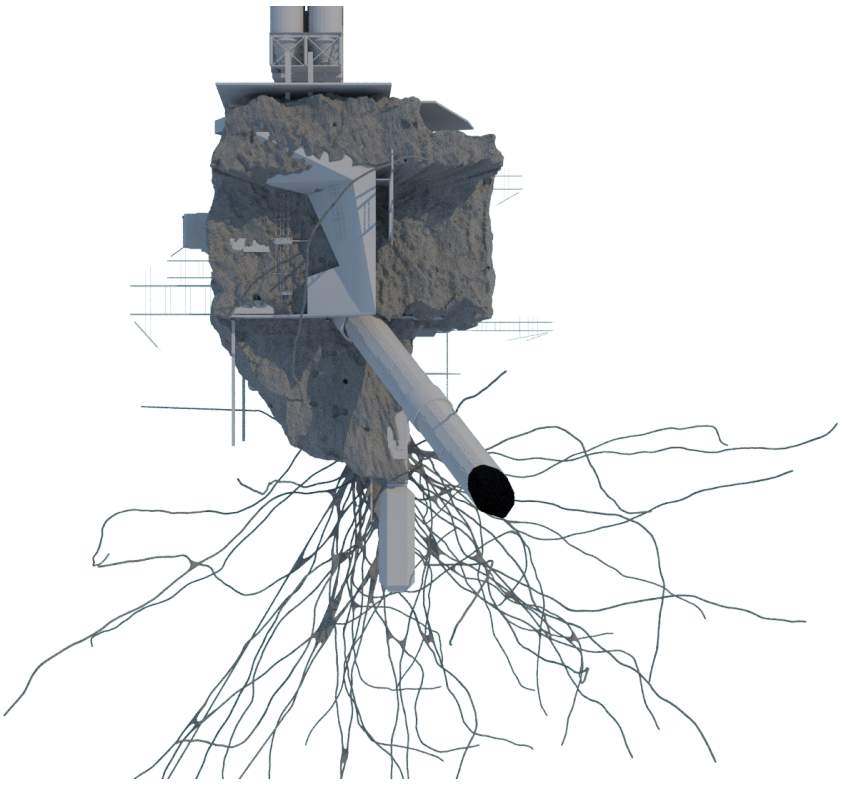
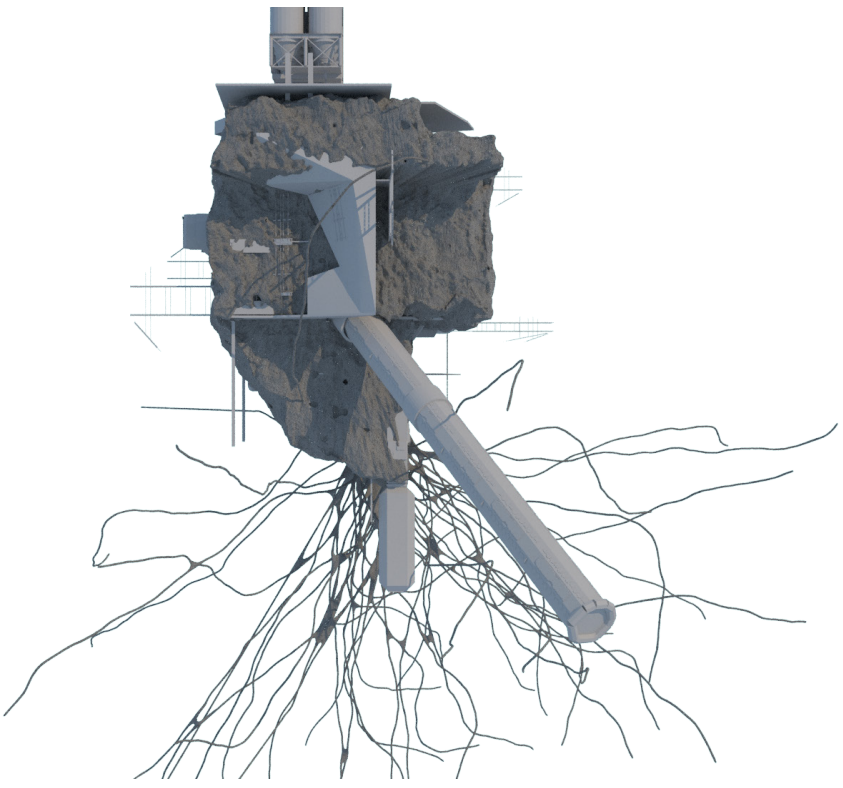

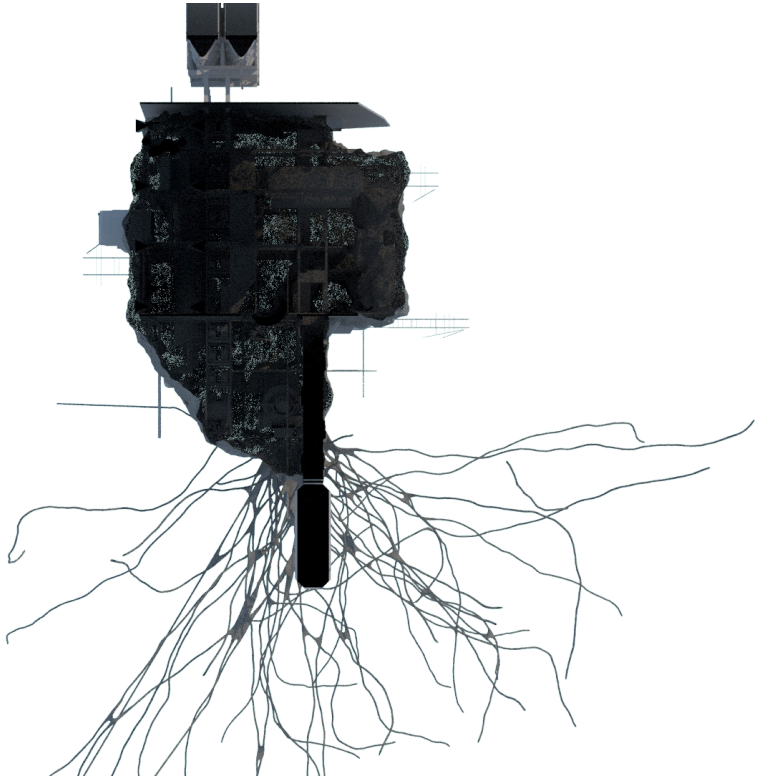

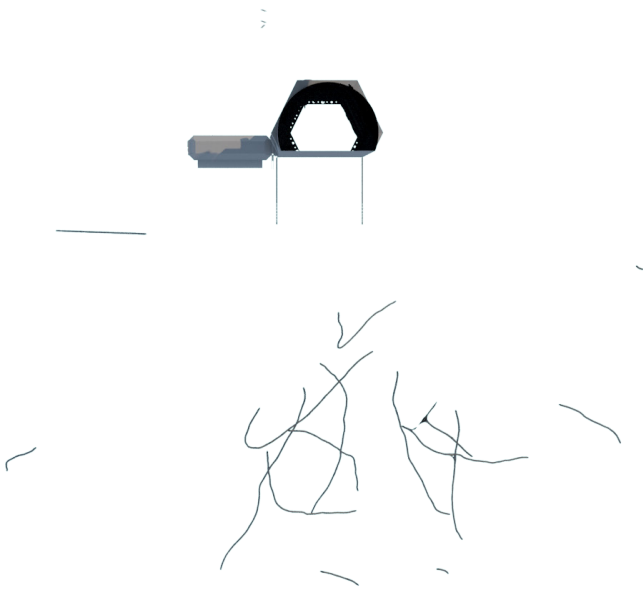



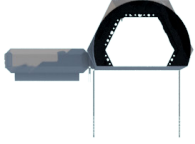
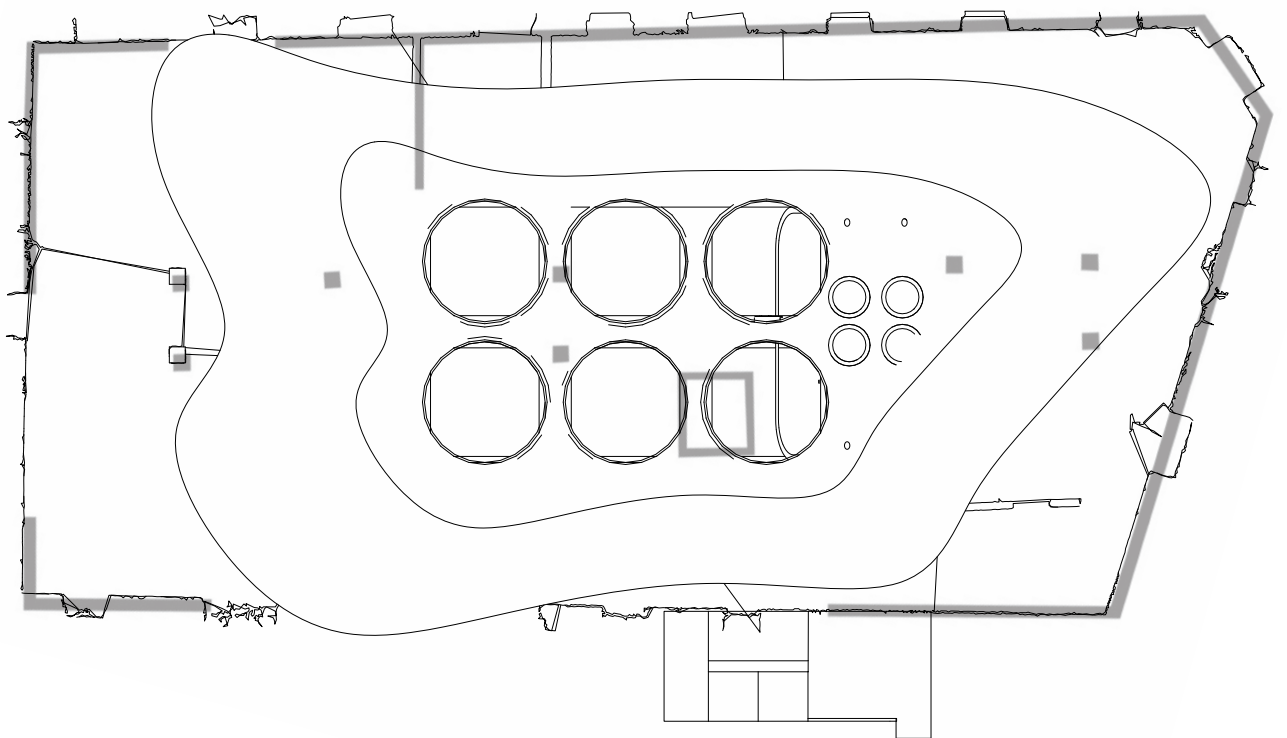

Not a direct action, but adaptation and re-transforming.

Not contra action of destroying the system, but a change of a system from within.

The physical space of a „protester/rebel base“ might be falsified construct — not found object/artifact.





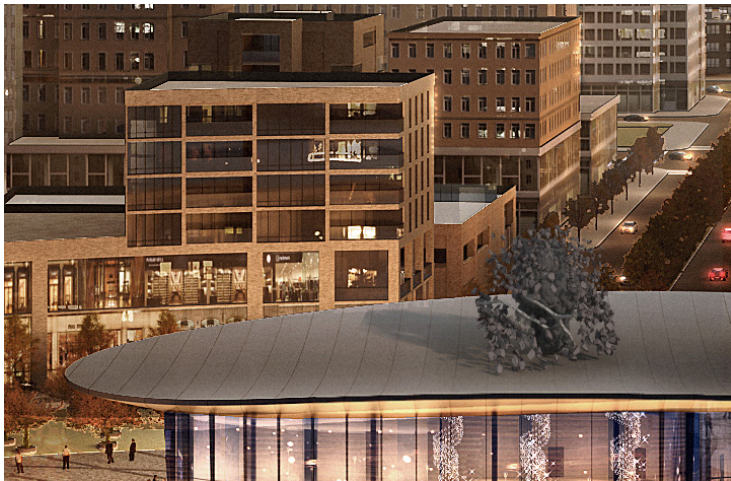

- Parasite-sabotage from within, not a protest on the street (old instrument)
- Political structure has its instruments to prevent the old fashioned rebellion.
- Not a direct action, but adaptation and re-transforming.
- Not contra action of destroying the system, but a change of a system from within.
- The physical space of a “protester/rebel base” might be falsified construct — not found object/artifact.



**Sign exist but signified doesn't.**

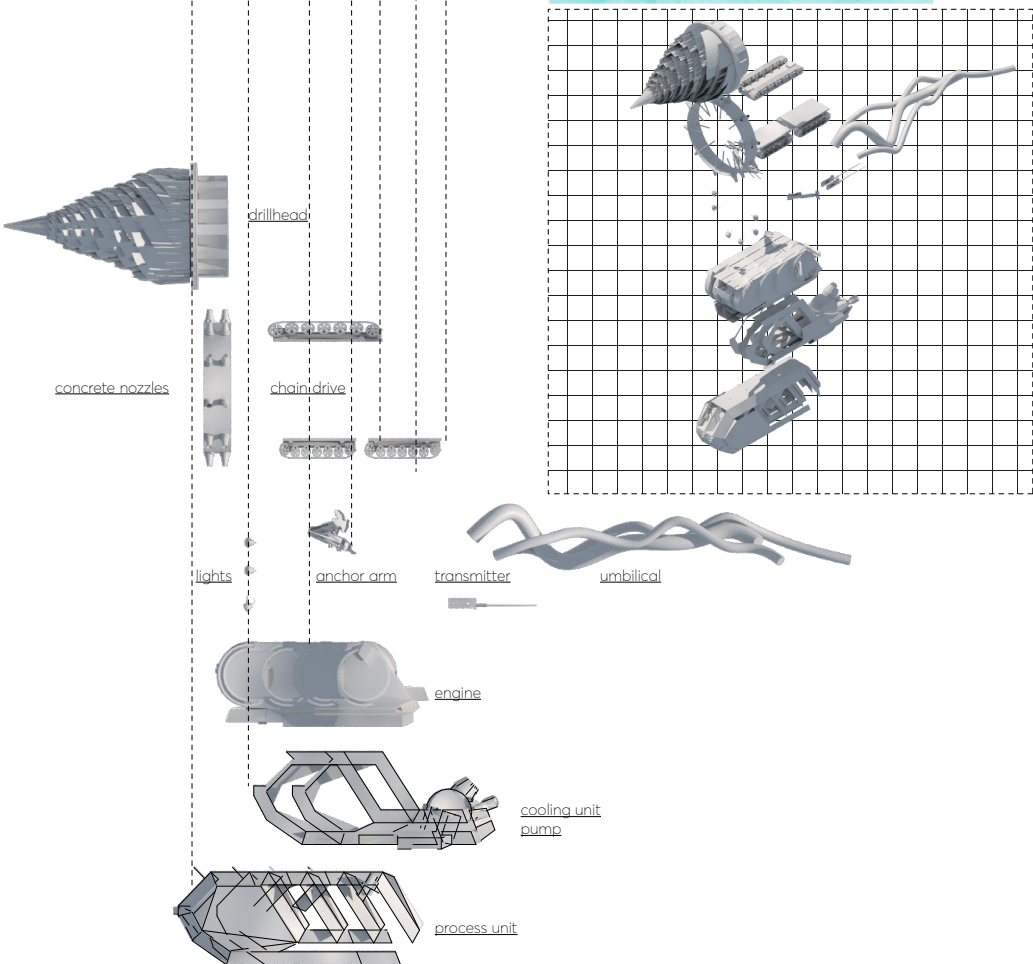
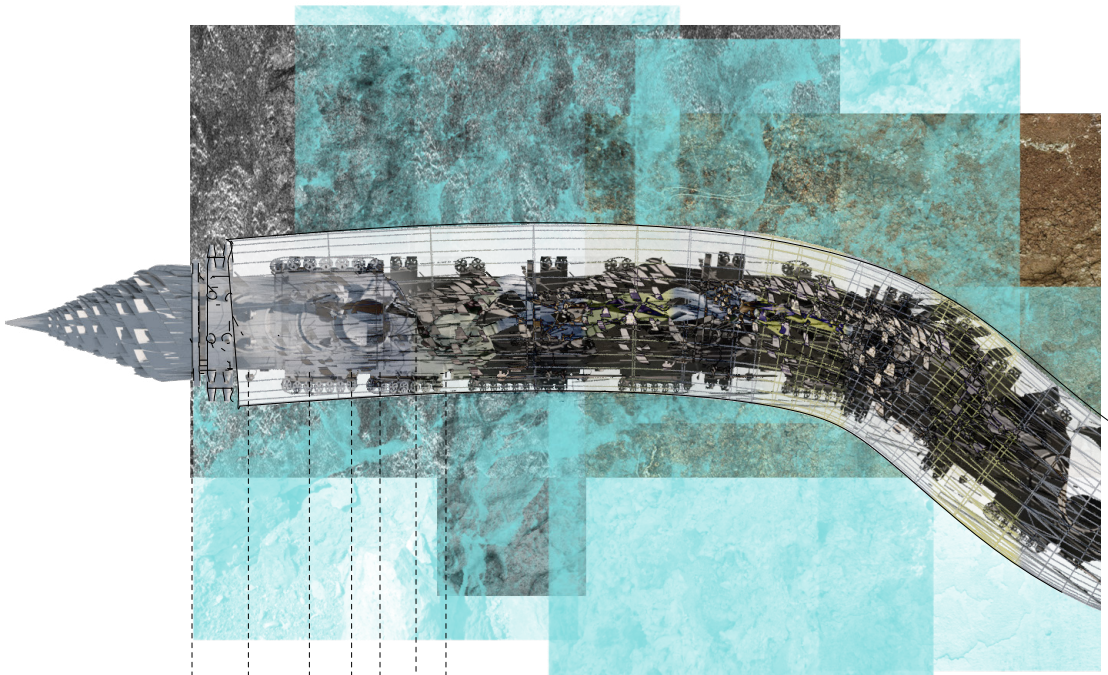



# THE DUCK PIT

Belgrade

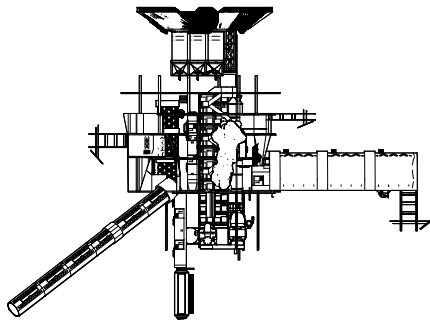
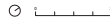
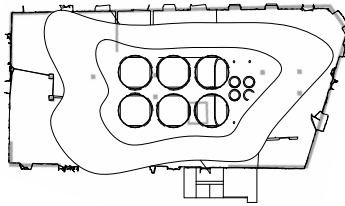
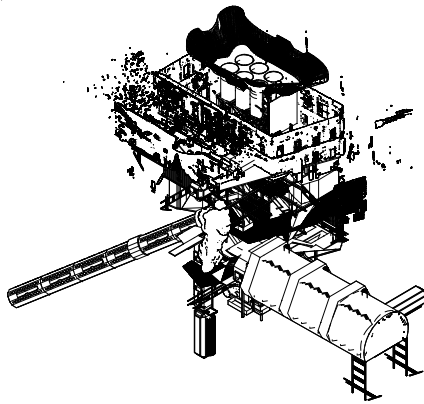

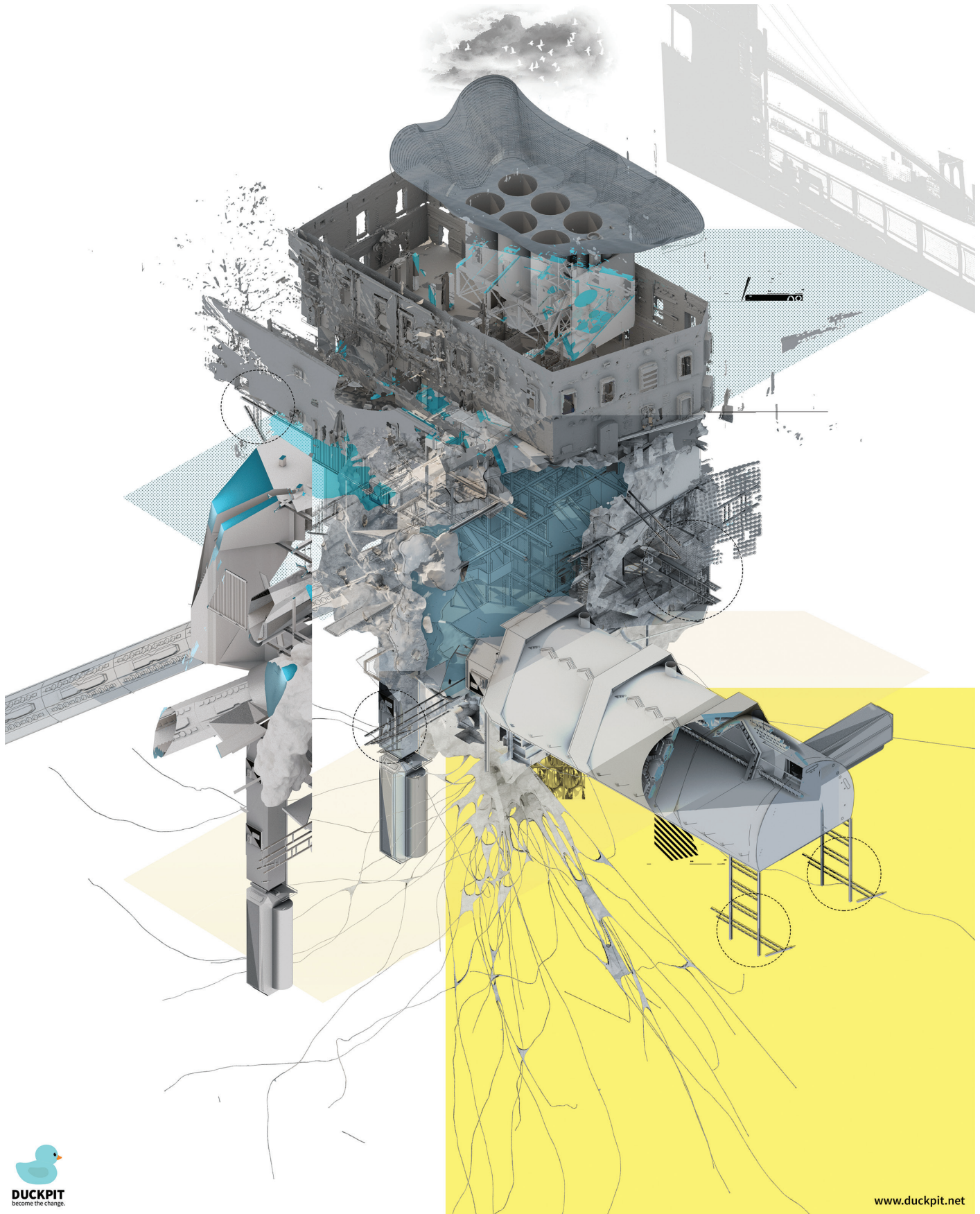



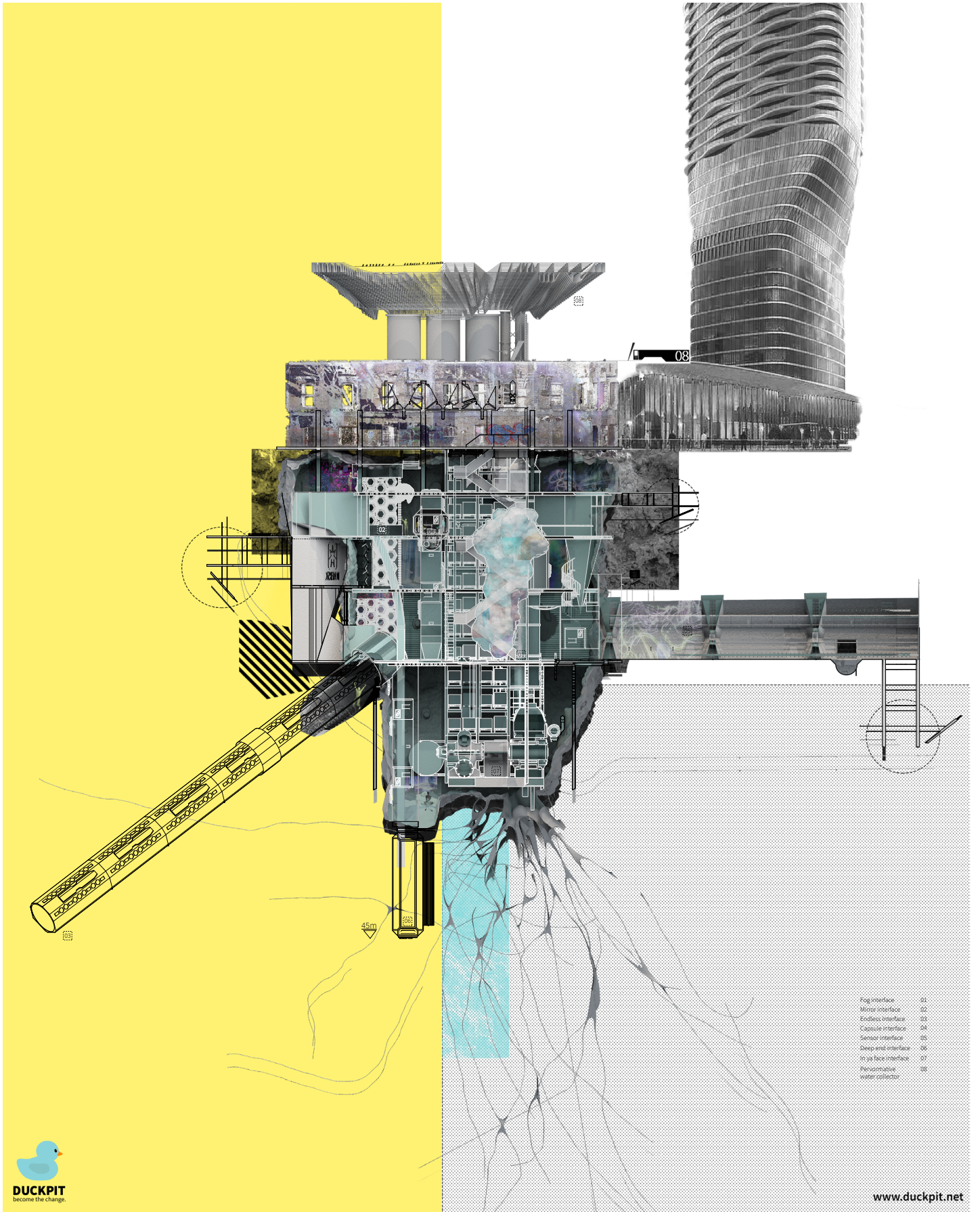

Fog interface	01
Mirror interface	02
Endless interface	03
Capacitive interface	04
Sensor interface	05
Deep end interface	06
In ya face interface	07
Permeable water collector	08

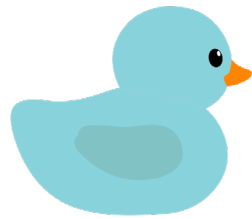

**DUCKPIT**  
become the change.

[www.duckpit.net](http://www.duckpit.net)





### Find out what 'Duckpit' is all about

(Please read the full story or else the page won't open)

A megalomaniac project backed by the promise of Abu Dhabi money is forcefully pushed forward by sidestepping laws and ignoring existing urban fabric, in order to secure the future identity of Serbia and its capital.

#### INFO

The project is presented as a public-private partnership between Serbia and Eagle Hills. Belgrade will provide the land equipped with infrastructure while the private company will invest into buildings. Once again the plan failed to reveal the official contract between the two countries and the nature of the public-private partnership.

There is no sign of its actual existence or knowledge of details, legal status, government and plans with the city of Belgrade and its citizens have. After the change of the Building and Planning Act (BIA), the Belgrade Waterfront project overcame all legal obstacles and construction was ready to begin. The official opening of the first and grand 5th object, a stand on paper, a restaurant-bar is ready...

### Did you know the serbian word for duck is „Patka“?

ПАТКА - „patka“ (noun)  
/du:k/, uam, pmo: (mrg:)

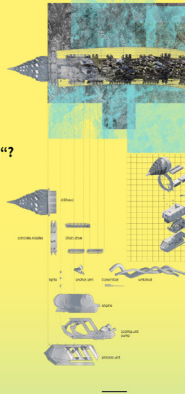

### Grow an epidemic - make a change.

Use your cursor to help the virus grow - by clicking and dragging through out the animations you can manipulate the existing structures of the rendering.



### How do you become the change?

Good question! No need to donate any money or protest in front of an old building as before. Simply spread the message of this page by hitting a Duckpit like so:

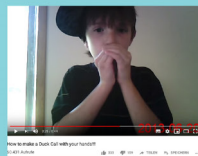

@duckpit

