



CATALOGUE 2024

Handcrafted  
furniture  
made from  
selected materials  
designed  
with love by  
Clémentine  
Caurier\*

\*Collection de meubles, créée avec passion par Clémentine Caurier, fabriquée avec des artisans.



# RUA CHA SERIES

Initially, RUA CHA series is designed for a portuense interior. Conviviality and simplicity are the keywords of this first creation.

In its development, the minimalism of the lines and subtlety of details allow each piece to be easily integrated into a wide variety of spaces. The generous curves make them warm elements and their quality, both in the respectful choice of materials and their use, make them durable companions.

*La série RUA CHA a été dessinée initialement pour un intérieur portuan. Convivialité et simplicité sont les maîtres mots de cette première création et de son développement. Le minimalisme des lignes et la subtilité des détails permettent à chaque pièce de s'intégrer aisément à des espaces très variés. Les courbes généreuses en font des éléments chaleureux et leur qualité, tant dans le choix respectueux des matériaux que dans leur utilisation, en font des compagnons durables.*

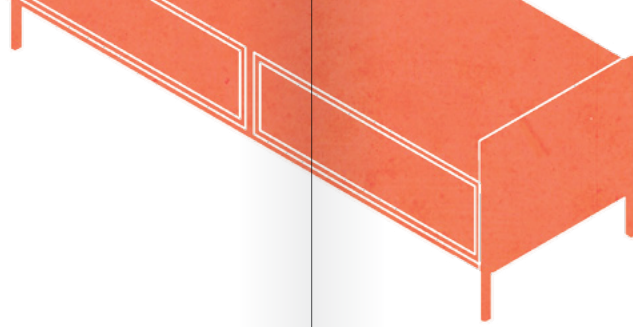

EXTENDABLE TABLES *TABLES*

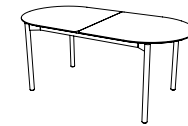

P 08 - 13

DINING CHAIRS *CHAISES*



P 14 - 23

SOFAS *CANAPÉS*

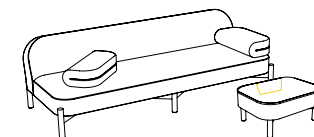

P 24 - 29

SIDEBOARD *ENFILADE*

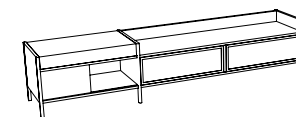

P 30 - 33

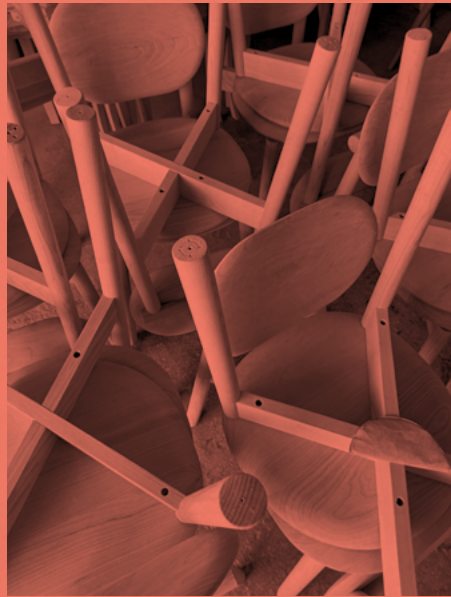

1.



2.



3.

1. First production of chairs awaiting finishing stage / 2 & 3. Technical tests on the first prototypes of the RUA CHA table / 4. Table tops finishing to give the best protection to the wood / 5. Inner structure of the RUA CHA sofa ready to be upholstered / 6. Last step of a long sewing process: staples.

1. Première production de chaises en attente de finitions / 2 & 3. Essais techniques sur les premiers prototypes de la table RUA CHA / 4. Finition des plateaux afin de donner la meilleure protection au bois / 5. Structure interne du sofa RUA CHA prêt à être rembourré / 6. Dernière étape d'un long travail de couture : les agrafes.



4.



5.



6.



# TABLES

RUA CHA table is a light, extendable table in solid wood. Its geometric lines and slim width make it easy to integrate into a wide variety of spaces, and its rounded softness invites people to gather. Thanks to its integrated extension leaf and synchronized opening, it becomes resolutely a contemporary object, and it can accommodate between 6 and 10 place settings while retaining perfectly its elegance and finesse. Its protective finish makes it soft to the touch and is entirely in keeping with its natural character. The wood grain is apparent in all finishes.

*La table RUA CHA est une table légère, en bois massif, à rallonge. Ses lignes géométriques et sa petite taille l'intègrent aisément dans des espaces très variés, et sa rondeur invite au rassemblement.*

*Grâce à sa rallonge intégrée, très facile à manipuler, elle devient un objet résolument contemporain. Elle a la capacité d'accueillir entre 6 et 10 couverts sans perdre de son élégance et de sa finesse.*

*Ses finitions protectrices la rendent douce au toucher et n'enlèvent rien à son caractère naturel. Quelle que soit sa teinte, les nervures du bois sont visibles.*

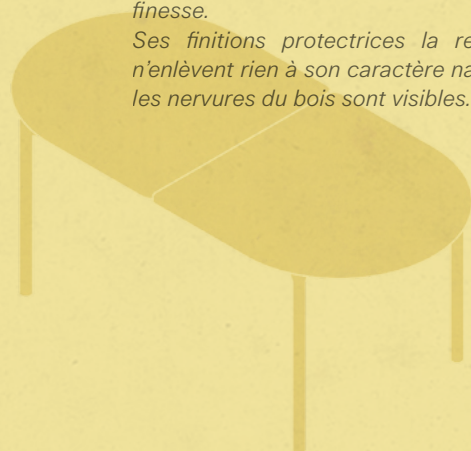

# TABLE NATURAL

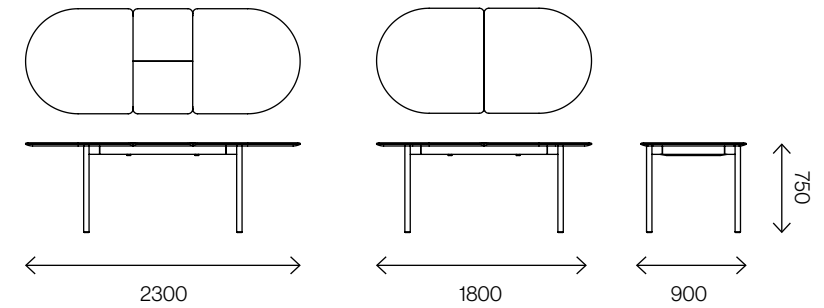

ORIGIN <i>origine</i>	<b>Portugal</b> <i>Portugal</i>
WOOD <i>bois</i>	<b>solid ash</b> <i>frêne massif</i>
WOOD FINISHING <i> finition bois</i>	<b>natural color</b> <i> couleur nature</i>
EXTENSION 50 cm <i>rallonge 50 cm</i>	<b>inside the table</b> <i>à l'intérieur de la table</i>
DISMOUNTABLE LEGS <i> pieds démontables</i>	<b>yes</b> <i>oui</i>



# TABLE BROWN

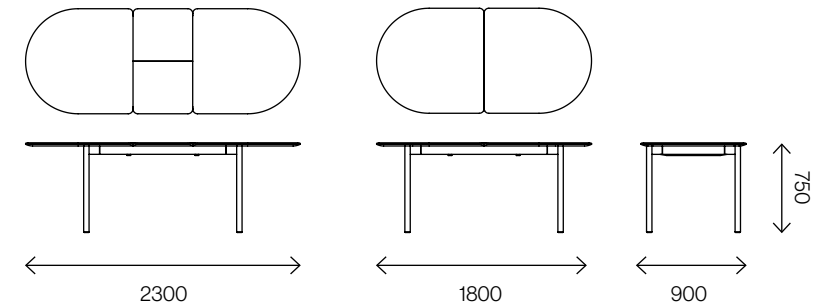

ORIGIN <i>origine</i>	<b>Portugal</b> <i>Portugal</i>
WOOD <i>bois</i>	<b>solid ash</b> <i>frêne massif</i>
WOOD FINISHING <i> finition bois</i>	<b>brown color</b> <i>couleur chataigne</i>
EXTENSION 50 cm <i>rallonge 50 cm</i>	<b>inside the table</b> <i>à l'intérieur de la table</i>
DISMOUNTABLE LEGS <i> pieds démontables</i>	<b>yes</b> <i>oui</i>



# CHAIRS

RUA CHA chairs are made of solid wood.

The carved shape of both the backrest and the seat guarantee great comfort. Their simple geometry matches the lines of the extendable table and gives a rustic-contemporary character to the whole.

They have been given a protective finish in different colours, but with clearly visible wood grain they retain their genuine natural character.

*Les chaises RUA CHA sont faites de bois massif.*

*La forme sculptée du dossier et de l'assise garantit un bon confort.*

*Leur géométrie simple s'accorde aux lignes de la table à rallonge et donne à l'ensemble un caractère rustico-contemporain.*

*Elles ont reçu une finition protectrice de couleurs différentes mais gardent néanmoins, grâce aux nervures du bois bien visibles, tout leur caractère naturel.*





# CHAIR NATURAL

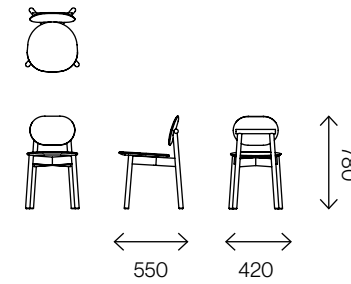

ORIGIN <i>origine</i>	<b>Portugal</b> <i>Portugal</i>
WOOD <i>bois</i>	<b>solid ash</b> <i>frêne massif</i>
WOOD FINISHING <i> finition bois</i>	<b>natural color</b> <i> couleur nature</i>
STACKABLE <i>empilable</i>	<b>by two</b> <i>par deux</i>
DISMOUNTABLE <i>démontable</i>	<b>no</b> <i>non</i>



# CHAIR BROWN

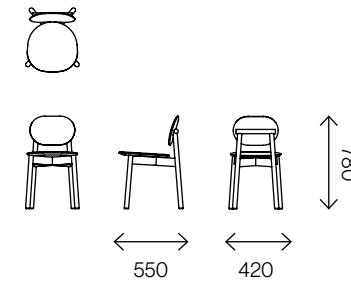

ORIGIN	<b>Portugal</b>
<i>origine</i>	<i>Portugal</i>
WOOD	<b>solid ash</b>
<i>bois</i>	<i>frêne massif</i>
WOOD FINISHING	<b>brown color</b>
<i> finition bois</i>	<i> couleur châtaigne</i>
STACKABLE	<b>by two</b>
<i>empilable</i>	<i>par deux</i>
DISMOUNTABLE	<b>no</b>
<i>démontable</i>	<i>non</i>



# CHAIR BLACK

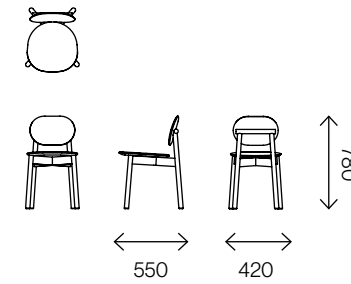

ORIGIN <i>origine</i>	<b>Portugal</b> <i>Portugal</i>
WOOD <i>bois</i>	<b>solid ash</b> <i>frêne massif</i>
WOOD FINISHING <i> finition bois</i>	<b>black color</b> <i>couleur noire</i>
STACKABLE <i>empilable</i>	<b>by two</b> <i>par deux</i>
DISMOUNTABLE <i>démontable</i>	<b>no</b> <i>non</i>



# CHAIR GREEN

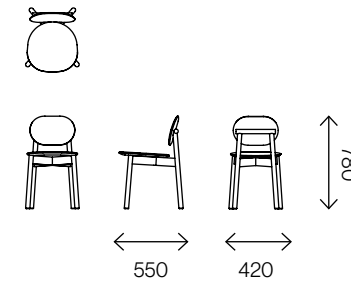

ORIGIN <i>origine</i>	<b>Portugal</b> <i>Portugal</i>
WOOD <i>bois</i>	<b>solid ash</b> <i>frêne massif</i>
WOOD FINISHING <i> finition bois</i>	<b>green color</b> <i> couleur vert forêt</i>
STACKABLE <i>empilable</i>	<b>by two</b> <i>par deux</i>
DISMOUNTABLE <i>démontable</i>	<b>no</b> <i>non</i>



# SOFAS

RUA CHA sofa is based on a light, crossed structure in solid wood. The generous curves are first padded with a high density memory foam and then covered with natural fibers, wool and linen. Its low, deep seat invites you to relax and the removable armrests give you a feeling of great freedom in the way you can approach it. Its quality lies in the choice of materials as well as in their execution.

It is available in 2 and 3 seaters, can be combined with a pouf and can be covered in a wide range of colours.

*Le sofa RUA CHA repose sur une structure légère croisée, en frêne massif. Enveloppé d'un rembourrage aux courbes généreuses, il est habillé de mousse à mémoire de forme, puis de laine et de lin, fibres naturelles. Son assise basse et profonde invite à la détente et ses accoudoirs amovibles apportent une grande liberté dans la manière de l'appréhender. Sa qualité réside aussi bien dans le choix des matériaux que dans leur mise en œuvre.*

*Il est disponible en 2 et 3 places, peut être accompagné d'un pouf et peut revêtir une large palette de couleurs.*



SOFA 2-SEATER OR 3-SEATER

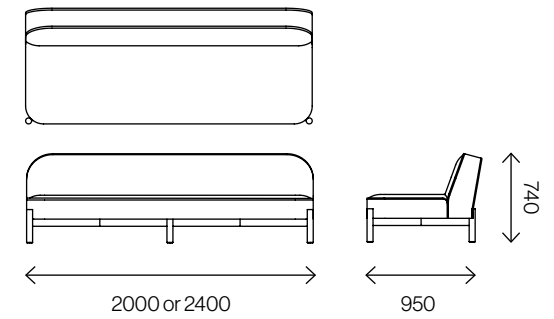

ORIGIN <i>origine</i>	<b>Portugal</b> <i>Portugal</i>
WOOD <i>matériau - structure intérieure</i>	<b>solid ash</b> <i>frêne massif</i>
WOOD FINISHING <i> finition bois</i>	<b>natural</b> <i>couleur nature</i>
FABRIC COMPOSITION <i>composition tissus</i>	<b>75% virgin wool - 25% linen</b> <i>75% laine vierge - 25% lin</i>
FABRIC COLOR <i>couleur tissus</i>	



POUF

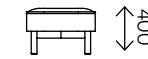
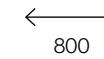
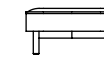
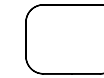

ORIGIN <i>origine</i>	<b>Portugal</b> <i>Portugal</i>
--------------------------	------------------------------------

WOOD <i>matériau - structure intérieure</i>	<b>solid ash</b> <i>frêne massif</i>
--	---

WOOD FINISHING <i> finition bois</i>	<b>natural</b> <i>couleur nature</i>
---	---

FABRIC COMPOSITION <i>composition tissus</i>	<b>75% virgin wool - 25% linen</b> <i>75% laine vierge - 25% lin</i>
---	---

FABRIC COLOR <i>couleur tissus</i>	
---------------------------------------	--



# SIDEBOARD

RUA CHA sideboard is a slender silhouette, solid wood piece of furniture designed to welcome a hi-fi system. Its architecture, its mechanisms and the use of textile make it a very functional object.

The left-hand compartment with its sliding lid can accommodate a record player and vinyl records. Two other compartments on the bottom right can accommodate an amplifier, hi-fi system or speakers. The fabric doors allow sound and infrared signals to pass through easily. The opening at the back gives permanent access to cables.

The long line is elegant and the organic combination of wood and fabric makes it a warm addition to any space.

*L'enfilade RUA CHA est une longue pièce en bois massif conçue pour accueillir un système Hi-fi. Son architecture, ses mécanismes et l'utilisation de textile en font un meuble très fonctionnel.*

*Le compartiment de gauche au couvercle coulissant permet d'héberger une platine ainsi que des vinyles. Deux autres compartiments, en bas à droite, permettent d'accueillir amplificateur, chaîne - Hifi ou enceintes. Les portes en tissu permettent au son et aux signaux infrarouges de passer facilement. L'ouverture prévue à l'arrière donne un accès permanent aux câbles.*

*Sa longue ligne est élégante et le mariage organique du bois et du tissu la font s'intégrer chaleureusement à l'espace.*





# SIDEBOARD

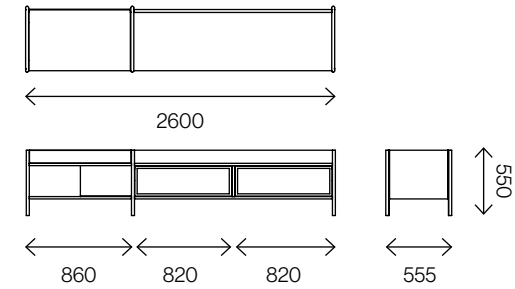

ORIGIN	<b>Portugal</b>
<i>origine</i>	<i>Portugal</i>
WOOD	<b>solid ash</b>
<i>bois</i>	<i>frêne massif</i>
WOOD FINISHING	<b>natural color / black color</b>
<i> finition bois</i>	<i> couleur nature / noire</i>
FABRIC COMPOSITION	<b>90% virgin wool - 10% nylon</b>
<i> composition tissus</i>	<i> 90% laine vierge - 10% nylon</i>
DISMOUNTABLE	<b>yes</b>
<i>démontable</i>	<i>oui</i>







## THE DESIGNER

Clémentine Caurier is born in France in 1986. She grows up in Ardèche, Marseille and Nancy. At 17, she decides to study Industrial Design. Her five years at Ecole de Design Nantes Atlantique, completed by one year at the IAE in Nantes, leads her to a double Master's degree in Product Design and Business Administration. At the same time, she attends workshop classes at the Hochschule für Gestaltung in Schwäbisch Gmünd (Germany). Touched by the design approach via the material, she chooses Germany for a second time for her end-of-studies internship.

Berlin is a revelation for her. She discovers a real space of freedom of expression within an international creative community. She immediately becomes an independent designer and begins collaborating with various design studios. It is with the designers Moritz Böttcher, Sören Henssler and Nikolaus Kayser that she discovers the world of furniture. After a few years of experience and the co-creation of numerous award-winning projects, she decides to develop her own creations for furniture brands, as well as her manual skills, particularly through ceramic work.

From 2015, her professional choices lead her to travel more and more. During this same period, she frequently teaches at the design school of Rubika Valenciennes, and at the Design school of Pune in India. She increases her knowledge of ceramics in Southern Europe and quickly established strong and creative links in Portugal.

There she discovers a developed craft world and sees the opportunity to complete her technical knowledge in the world of furniture.

This is followed in 2017 by increasingly frequent trips between Berlin, France and Portugal, the prototyping of what will become RUA CHA series in 2020, as well as the creation of Clémentine Caurier Collection.

## LA CRÉATRICE

*Clémentine Caurier est née en France en 1986. Elle a grandi en Ardèche, à Marseille puis à Nancy. À 17 ans, elle décide d'étudier le Design Industriel. Ses 5 ans à l'École de Design Nantes Atlantique, complétés par une année à l'IAE de Nantes la conduisent vers un double Master en Design Produit et Administration des entreprises. En parallèle, elle suit un enseignement en atelier à la Hochschule für Gestaltung de Schwäbisch Gmünd (Allemagne). Touchée par l'approche du design via la matière, elle choisit une seconde fois l'Allemagne pour son stage de fin d'études.*

*Berlin est pour elle une révélation. Elle y découvre un réel espace de liberté d'expression au sein d'une communauté créative internationale. Elle devient immédiatement designer indépendante et multiplie les collaborations avec différents studios de design. C'est notamment avec les designers Moritz Böttcher, Sören Henssler et Nikolaus Kayser qu'elle découvre le monde du mobilier. Après quelques années d'expérience et la coréalisation de nombreux projets récompensés, elle décide de développer ses propres créations pour des marques de mobilier, ainsi que ses compétences manuelles, notamment à travers le travail de la céramique.*

*À partir de 2015, ses choix professionnels l'amènent à voyager de plus en plus. Durant cette même période, elle intervient fréquemment à l'école de design de Rubika Valenciennes, puis à celle de Pune en Inde. Elle approfondit ses connaissances en céramique dans le Sud de l'Europe et tisse rapidement des liens solides et créatifs avec le Portugal.*

*Elle y découvre un monde artisanal développé et y voit l'opportunité de compléter ses connaissances techniques dans l'univers du mobilier.*

*S'en suivent en 2017, des allers-retours de plus en plus fréquents entre Berlin, la France et le Portugal, le prototypage de ce qui deviendra en 2020 la série RUA CHA, ainsi que la création de Clémentine Caurier Collection.*

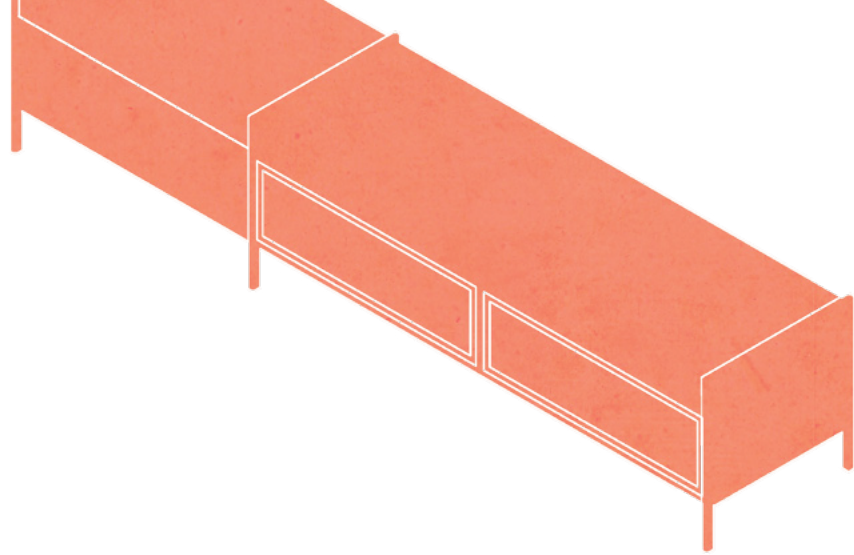

## CONTACT

IG @clementinecauriercollection

[www.clementinecauriercollection.com](http://www.clementinecauriercollection.com)

clementinecaurier@gmail.com

## CREDIT

**PHOTOGRAPHY** by filipaalves.com

**HOMEWEAR** by bicla.com.pt

**SPECIAL THANKS** to Pedro Marques,  
Claudia Alemão & Filipa Alves,  
Marie-Anne Caurier & Damien Flynn.

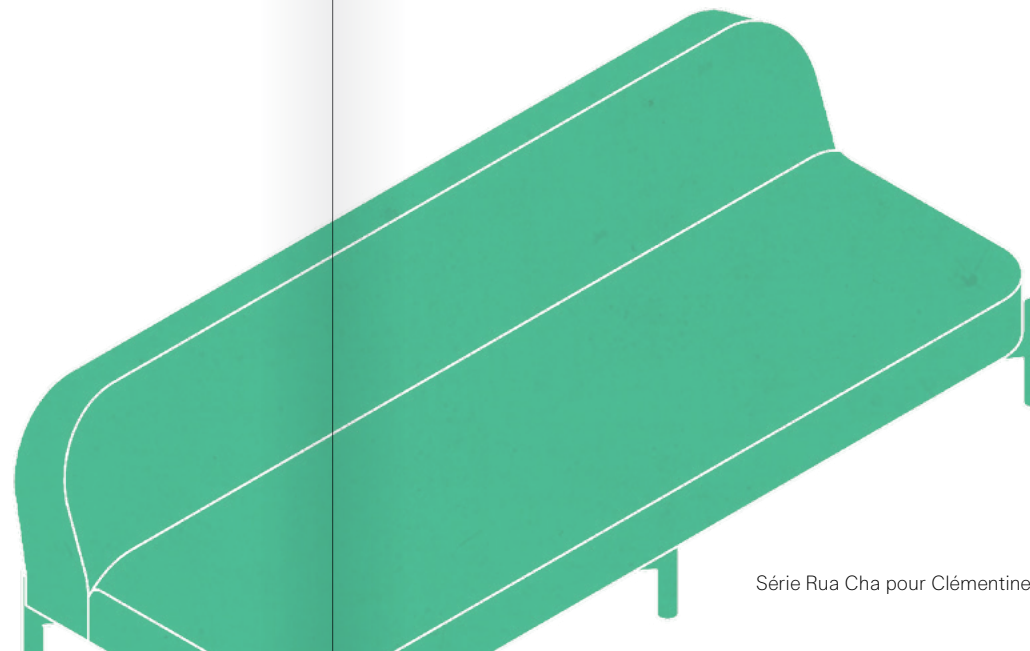



Clementine  
Courier  
Collection