

The Public Bathroom:  
Tracing a History of Architectural Symbolism and Social Control

Senior Project Submitted to  
The Division of the Arts  
of Bard College

by  
Mayim Frieden

Annandale-on-Hudson, New York  
May 2022





## Acknowledgments

To my ima and my abba for showing me how important it is to love, dream, ask questions and follow your gut. To my ima--thank you for being there from thousands of miles away every day of these past four years, keeping me company over the phone when I needed it most. To my abba--thank you for your endless encouragement and goofiness, and for passing on an appreciation for music, reading and hardware stores.

To my older siblings--Tal, Galya and Aylah--thank you for leading the way, letting me learn from you, giving the biggest hugs and most honest advice. I wouldn't be who I am today if it weren't for being your youngest sibling, and all of the blessings that have come with that.

To Amalia, my forever baby niece, for being the sweetest and silliest source of love, especially when college felt harder than ever, and for being a reminder that there is a new generation that needs to be heard and cared for.

To my grandma, thank you for supporting this thesis before it even began through your love, curiosity and wholehearted interest in me, my ideas and my ambitions. I am so lucky to have you.

Thank you to my advisor, Olga Touloumi--working with you on this thesis and my other projects over the last four years has made academic work exciting, fun and endlessly thought-provoking. My fascinations with architecture and architectural history have been able to take form with your insight and support.

This thesis could not have been completed without you all, or without the laughter, love, hugs, music, walks, talks, drives, Facetimes, coffees, breakfasts, lunches, dinners and desserts that I have been lucky enough to share with the sweet, hilarious, genius and incredible people close to me near and far. Thank you for bringing warmth, comfort and happiness into my life.

And, thank you to the architects and designers across the country and world that are dedicating their lives to rejecting these disciplines' long-expired selectivity and rigidity--for demonstrating that our world can be designed with genuinity and care, and that our built environments can be sustainable, inclusive, relaxing and enlivening all at once.



# Table of Contents

Introduction.....	1
Chapter 1: Public Bathrooms as Public Health.....	16
Chapter 2: Constructing a Standard.....	42
Chapter 3: Disrupting the Standard.....	80
Epilogue.....	105
Works Cited.....	117
List of Figures.....	124



## Introduction

“To talk about architecture without talking about toilets is to operate in denial of a whole array of sexual, psychological, and moral economies. For all the endless apparent talk about the body in architecture, architects don’t really want to talk about it. Architectural discourse is a deodorizer.”

Beatriz Colomina and Mark Wigley, “Toilet Architecture: An Essay About The Most Psychosexually Charged Room In A Building”

When asked the topic of this thesis, I was frequently met with scrunched eyebrows or laughter, told it was such a random, cute, silly idea. Taking public bathrooms up as a genuinely serious analysis was treated as a quirk or a punchline. Throughout my research, I noticed a similar trend; articles written on public bathrooms in the United States continuously relied on humor and puns in their titles, as if this topic was too boring, or too embarrassing, to address straightforwardly. When discussions of public bathrooms in this country were not disguised by jokes or danced around, they were either lacking crucial historical context or entirely absent. Across the United States, the discipline of architecture has hardly referenced the public bathroom as a site for deliberation or design. Regardless of the baseline understanding across this country that public bathrooms should be a consistent component of the built environment, people really don’t want to think or talk about them until they find themselves searching for one. Public bathrooms have been oversimplified and, as a result, largely ignored as a piece of history.

The United States has been conditioned to reduce the public bathroom into a set of oftentimes paradoxical expectations. They’re free, but might be locked depending on the hour. They will always be separated into two sides, yet for no reason other than ingrained social codes regarding gender. They are expected to be clean and sterile, though simultaneously anticipated to be spaces of disorder. They are the site of a quick, biological errand, nevertheless lines or long waits are prepared for. They have been associated with automatic and systematic technologies,

yet concurrently, these technologies are often labeled ‘out of order’ or discovered to be as such. In the United States, not only is the public bathroom as a piece of architecture and infrastructure taken for granted, but its complexities and contradictions are ignored or, alternatively, found laughable--its complex, 150-year history leaving little to no trace.

Though amused feedback to the topic of this thesis was common, there were fortunately alternative responses that demonstrated public bathrooms’ contestation and controversies. Often referencing the discomfort or frustration they have felt from prior experiences in this space, the selection of this topic provided others with relief or appreciation rather than laughter. Though framed by their title as ‘public,’ United States’ public bathrooms have been used to perpetuate exclusive stigmas since their inception. As a result, public bathrooms have continuously functioned as a tool of social regulation and ostracization. For those who have been on the receiving end of this, public bathrooms are disorienting at best and dangerous at worst.

Throughout their history, public bathrooms across the United States have entrenched social divisions regarding race, gender, class and disability further into the built environment--who you are and how you are perceived societally has influenced how the public bathroom will treat you as a result. As somebody that is non-binary and trans masc, public bathrooms have been both anxiety-inducing and disheartening. Picking a side feels unnatural and within either, I feel out of place, as though either way I’ve made the wrong choice. Public bathrooms have materialized the United States’ concerning tendency to divide and categorize, in turn prescribing or imposing certain behaviors and dynamics.

This thesis examines the relationship facilitated between architecture and urban publics by exploring public bathrooms in New York City as a historical and contemporary development. Studying this relationship reveals how government agents, administrators and architects have

continuously used public architecture as a tool for conditioning and controlling certain mentalities, behaviors and dynamics within the public. This relationship requires an interrogation of how these actors have defined and characterized this ‘urban public’ and who has been ostracized or ignored as a result. This examination depends upon the site and period being studied, since different publics have been identified and addressed at various moments, depending upon the interests or intentions of the city, planner, or architect. This analysis is particularly important regarding the public bathroom, since it has intended to serve substantially different publics, and breed varying behaviors, throughout distinct periods in history.

Because the notion of a public bathroom is reliant on its instated ‘public’ nature, it is a particularly significant site for understanding how New York City has imagined, and consequently interacted with, its urban public. This dynamic most formally begins during the nineteenth century, when public bathhouses, comfort stations and bathrooms were deemed components of New York City’s ‘Americanizing’ agenda; in response to the circulation of new, deadly epidemics, the white upper class had determined that low-income, Black and immigrant communities’ lack of ‘American’ hygiene practices were debilitating the overall health and success of the city, and thus public sanitary services were born. This dynamic has changed with the city--as new anxieties, fears or stigmas have spread regarding the conditions and behaviors of the public, the public bathroom has shifted in response. This thesis argues that the public bathroom has continuously symbolized particular sociocultural beliefs, and functioned as a tool of social control and regulation as a result.

## Constructing Space with Language

Defining the public bathroom has always been ambiguous, its name ranging and evolving throughout time and place. Linguistically, minor contextual factors distinguish the terms “bathroom” and “restroom,” the two words most commonly used today when referencing this space. The Oxford English Dictionary states that the term “bathroom” was initially created in the late 1600s to refer specifically to a public room “containing facilities for bathing,” then reforming to refer exclusively to rooms in houses “for private bathing,” yet in the 1800s, became defined in North America as “a room containing a toilet or toilets, usually with facilities for handwashing, and sometimes also a bath or shower,” leaving room for ambiguity regarding the location, amenities and access of the space.<sup>1</sup> The word “restroom,” originating in the mid-1800s, was first defined as “a room (usually in a public building or workplace) set aside for rest and relaxation,” the means for experiencing this relaxation left undisclosed, later being redefined in the United States as “a lavatory in a public building or workplace”--therefore while both definitions explicitly signify the space’s public access, they do not disclose the features or fixtures to be expected.<sup>2</sup>

To only reference these two terms would be inaccurate since bathroom terminology has encompassed a range of alternatives over time: “washroom,” “water closet,” “comfort station,” “outhouse,” “loo,” “latrine,” “john,” “potty,” to name a few.<sup>3</sup> In New York City, the administrators and government officials that advocated for the first public toilets during the late 1800s did so using the term “comfort station,” defined now as “a room or building with toilet and lavatory facilities for public use.”<sup>4</sup> This term remained in use throughout the first half of the 20th

---

<sup>1</sup> “Bathroom,” *Oxford English Dictionary*, <https://www.oed.com/view/Entry/16165?redirectedFrom=bathroom#eid>.

<sup>2</sup> “Restroom,” *Oxford English Dictionary*, <https://www.oed.com/view/Entry/275516?redirectedFrom=restroom#eid>.

<sup>3</sup> “Restroom,” *Merriam-Webster*, <https://www.merriam-webster.com/thesaurus/restroom>; “Bathroom,” *Merriam-Webster*, <https://www.merriam-webster.com/thesaurus/bathroom>.

<sup>4</sup> “Comfort Station,” *Dictionary.com*, <https://www.dictionary.com/browse/comfort-station>.



century, replaced by the most commonly used terms today, ‘public bathroom’ and ‘public restroom’ during the second half of the 20th century. This etymological history provides insight into the various decisions involved in the initiation of public bathroom development--what fixtures and features should the space include, and consequently, what should it be societally associated with? Comfort? Rest? Bathing? Being public?

These records provided by the Oxford English Dictionary and Merriam-Webster do not comprise the full scope of public bathroom terminology either, instead providing the vocabulary used primarily by two Western countries (the United States and the United Kingdom). Cultural and spatial norms inspire language, causing terminological variation across the world; therefore, the Oxford English Dictionary and Merriam-Webster’s definitions are only relevant when referring to the specific geographic contexts above. Further, the term ‘comfort station’ has been used throughout various countries in regards to differing contexts. However, within New York City, this term was most predominantly used in reference to the first architectural form of the public bathroom.

Society has been taught how to perceive public bathrooms over time by-way-of their title and their architecture--yet, their terminology has forecasted and influenced the subsequent design process. Throughout the above record of terms, obscurity remains embedded within each. Both the terms which place direct emphasis on washing, bathing, or comfort, and alternatively, those with indistinct names such as “john,” rely upon a linguistically-motivated distraction from the true function of this space--completing natural, biological functions such as urinating, defecating, menstruating, vomiting, and a variety of other tasks that may or may not be natural or biological, yet which can take place in public bathrooms. Public bathrooms have never been referred to according to their direct purpose, reflecting the shame and discomfort that the United States in

particular has ascribed to the presence of one's body and its innate processes in public. The self-consciousness and embarrassment that this distanced terminology instituted then became embedded within the design of public bathrooms.

Throughout this thesis, I will be utilizing the term 'public comfort station' when discussing the periods in which this was the title most commonly employed. When discussing the public bathroom more generally, as a concept and as a piece of architecture, I will use the term 'public bathroom.' This is also the term I will use when discussing later periods, when it became one of the most customary ways of referring to this space. This term's root, 'bath,' is a reminder of the precursor to public bathrooms in New York City, public bathhouses. The histories of public bathhouses and public bathrooms are intertwined and both led to significant sociocultural shifts in perspective and behavior regarding the body, its perceived cleanliness and the enforced control over both. Therefore, this term is the most representative of the themes that will be explored in this thesis.

Furthermore, determining which bathrooms qualify as 'public' varies throughout the United States. Private businesses seldom open their bathrooms to the public--instead, oftentimes access is strictly limited to patrons or, alternatively, selectively prohibits certain populations of the public, such as houseless or non-English speaking people.<sup>5</sup> When discussing the public bathroom throughout this thesis, I am referring to bathrooms that are situated in free, non-restricted, locations--such as within New York City's streets, public squares and parks. This is not to argue that the public bathrooms within these locations do not regulate who can or cannot use them, but more so that they objectively *shouldn't*--the ways that they, indirectly, do so will be discussed.

---

<sup>5</sup> Julie Chou, Kevin A. Gurley and Boyeong Hong, "The Need for Public Bathrooms in New York City," *Urban Design Forum*, July 24, 2020, <https://urbandesignforum.org/proposals/the-need-for-public-bathrooms-in-new-york-city/>.

## Space, Period, Discipline

While the complex phenomenon of public bathrooms has not only been unraveling within New York City, this thesis will focus solely on the historical, social and cultural contexts of this city. This thesis will reference various pieces of New York City's public architecture--specifically the city's first public bathhouse and various public bathrooms--spanning from the late 1800s and into the 2010s. Throughout this large window of time, New York City has frequently been characterized by scholars, historians and popular culture as the most diverse city in the United States. While this diversity and multiculturalism has cultivated the stimulating and exciting nature of New York City, it has also been the impetus for social tensions since the first major waves of immigration into the city occurred in the 18th and 19th centuries. Architecture has been used to mediate and respond to social and cultural tensions, as it is capable of materializing and solidifying ideologies into the built environment. By cutting across New York City's relationship to the public bathroom over the last three centuries, this thesis will illustrate how city officials, administrators and architects have embedded various symbols into the public bathroom, in turn shaping it into a mechanism of social control.

The development of cities' built environments, and their relationship to the discipline of architecture, has been explored by various scholars, yet they often leave their analyses and arguments fixed in the time periods being studied. Historian Martin Melosi has discussed the obscurity between governmental versus individual obligation in cities during the 19th century, influencing how governments responded to the first public health crises, wherein they asserted individuals were responsible for protecting themselves from illness and death.<sup>6</sup> Architectural

---

<sup>6</sup> Martin Melosi, *The Sanitary City Urban Infrastructure in America from Colonial Times to the Present* (Baltimore: The Johns Hopkins University Press, 2000).

historian Andrea Renner has discussed New York City's appropriation of Europe's public bathhouses during the 19th century, in which a space of leisure and congregation became one of subordination and surveillance.<sup>7</sup> Urban historian Peter Baldwin has discussed the installation of the first public toilets in U.S. cities during the late 19th and early 20th centuries, and the impacts that this era had on cities' relationships to the body, privacy and notions of morality.<sup>8</sup>

Architecture professors, Paul Emmons and Andreea Mihalache, have discussed the rise of architectural handbooks and their use of the term 'the user' during the 1930s, which came as a result of mass-industrialization across the U.S. and the world, and the consequential shift it enacted in architectural design: "standardized buildings for standardized bodies."<sup>9</sup>

This thesis will draw from the theories, arguments and findings of these scholars, however it will also argue that these social, infrastructural and architectural histories continue to impact New York City's built environment and social fabric--specifically within the design, treatment and usage of public bathrooms. While the aforementioned scholars have positioned these phenomena as static moments in history, this thesis' exploration of the development of public bathrooms in New York City will illustrate how architectural design can uphold and sustain the ideologies and intentions of former centuries into the current moment and beyond. Many articles and books have been dedicated to the urban and architectural phenomenon these authors have discussed, yet very few, if any, have connected these themes and developments to the public bathroom.

Alternatively, several organizations have discussed and criticized the state of public bathrooms in New York City throughout the 2010s. For example, Chief Policy & Data Officer to

---

<sup>7</sup> Andrea Renner, "A Nation that Bathes Together: New York City's Progressive Era Public Baths," *Journal of the Society of Architectural Historians* 67, no. 4 (2008): 504-531.

<sup>8</sup> Peter C. Baldwin, "Public Privacy: Restrooms in American Cities, 1869-1932," *Journal of Social History* 48 no. 2 (2014): 264-288.

<sup>9</sup> Paul Emmons and Andreea Mihalache, "Architectural handbooks and the user experience," *Use Matters: an alternative history of architecture* ed. Kenny Cupers (New York: Routledge, 2013): 36-50.

the New York City Comptroller, Scott Stringer, conducted research on the conditions of public bathrooms across New York City’s parks--positioning these observations in opposition to “noteworthy efforts” in public bathroom development from prior periods.<sup>10</sup> Others have condemned the lack of “accessible, clean and safe” public bathrooms by arguing that they are “essential to a dignified public realm for all, especially those living on the street.”<sup>11</sup> Nonprofit organizations have been formed to “advocate for the availability of clean, safe and well-designed” public bathrooms by demanding the implementation of certain fixtures or protocols.<sup>12</sup> While this work has helped in illuminating current trends regarding the absence, closure or under-maintenance of public bathrooms, their arguments and proposals often lack consideration for their history within New York City and the United States. This thesis aims to situate the public bathroom within New York City’s urban history, alongside its infrastructural and architectural histories, to demonstrate how the state of public bathrooms that we are familiar with today is the direct product of the agendas and intentions from earlier periods.

The term ‘the public’ will play a significant role in this thesis, in reference to the population of New York City at any given time, which composes and activates the diverse and unpredictable nature of this city. Many people have discussed and complicated this phrase in depth, interrogating what and who it actually encompasses. Jürgen Habermas is often cited for contributing significant writing on this topic, known for defining ‘the public’ as “a sphere of private people,” composed of members of the bourgeois who believed they could represent the general public by discussing “public affairs.”<sup>13</sup> Many, if not most, people have disputed this

---

<sup>10</sup> “Discomfort Stations: The Conditions and Availability of NYC Parks Bathrooms,” *New York City Comptroller Brad Lander*, June 27, 2019, <https://comptroller.nyc.gov/reports/discomfort-stations-the-conditions-and-availability-of-nyc-parks-bathrooms/>.

<sup>11</sup> Chou, Gurley, Hong, “The Need for Public Bathrooms in New York City,” *Urban Design Forum*.

<sup>12</sup> “About Us,” *American Restroom Association*, <https://americanrestroom.org/about-us/>.

<sup>13</sup> Jürgen Habermas, *The Structural Transformation of the Public Sphere* (Cambridge: The MIT Press, 1989), 27.

definition and argued otherwise. Theorists such as Nancy Fraser have written in opposition to Habermas; beyond noting his classist and exclusive understanding and definition of ‘the public,’ Fraser has discussed ‘interpublic relations,’ which presumes not only that more than one ‘public’ exists, but that they continuously interact and influence one another.<sup>14</sup>

In “stratified societies,” such as the United States, where the “basic institutional framework generates unequal social groups” that are structured and shaped by relations of “dominance and subordination,” Fraser argues that there will always be more than one ‘public’.<sup>15</sup> When considering public architecture, the work of these two scholars is thought-provoking. In regards to Habermas’ arguments, public architecture is, in fact, often influenced and designed by a sphere of private actors, from politicians to government offices to donors, rarely including, or forming in direct response to the preferences of, the general public.<sup>16</sup> Further, public bathrooms have become a fixed, predictable architectural standard designed around a predetermined ‘user,’ therefore leaving little to no room for accommodating the various publics, or ‘interpublic relations,’ that Fraser attributes to societies like those of the United States.

This thesis will grapple with these scholars’ arguments when considering how the public bathroom has historically dealt with its ‘public’ nature. Habermas and Fraser’s theories have illustrated the discrepancies between what one would *think* ‘the public’ would mean and how it has been defined or functioned. Similarly, the public bathroom’s supposed ‘public’ nature contradicts with its exclusionary history and design. Drawing from Fraser’s discussion of counterpublics, this thesis will examine how public bathrooms in New York City were initially part of the white upper-class’s attempt to control and ostracize Black, immigrant and low-income

---

<sup>14</sup> Nancy Fraser, “Rethinking the Public Sphere: A Contribution to the Critique of Actually Existing Democracy,” *Social Text* 25/26 (1990): 58-60.

<sup>15</sup> *Ibid.*, 66-68.

<sup>16</sup> “Is Public Architecture Dysfunctional?” *Congress for the New Urbanism*, October 23, 2020, <https://www.cnu.org/publicsquare/2020/10/23/public-architecture-dysfunctional>.

communities on the basis of ‘hygiene.’ Public bathrooms continue to be a site where counterpublics interact and influence one another; the disabled, queer and trans communities have each enacted shifts in public bathroom perception and design as a response to sharing the space with counterpublics that have alternative needs and expectations.

The public bathroom, as a piece of architecture and social culture, has been discussed within various disciplines--most commonly, Gender and Sexuality Studies, Disability Studies and Sociological Studies. Ruth Barcan, Professor of Gender and Cultural Studies, has discussed how even the cleanest public bathrooms are perceived as “culturally dirty spaces,” in reference to their “technologies of concealment,” that obscure the presence of waste, and to their naturalization social categories through their gendered separation, both of which serve to divide and separate people and objects “whose proximity might otherwise be troubling.”<sup>17</sup> Architectural historians such as Barbara Penner have focused on modern architects’ influence on bathroom fixtures--for example, connecting the “standardized, white, and pristine, toilets” encountered today to the “cleansing drive of modernism”--and analyzing the lengths modern architects took to ensure that bathroom usage became a staple of the modern aesthetic.<sup>18</sup> Importantly, Penner centralized domestic bathrooms in her discussion, a trend I encountered frequently throughout my research, further exemplifying how public bathrooms have been dismissed and removed from conversations on historical, cultural and architectural movements.

David Serlin, a professor who researches historical and cultural approaches to disability, is one of many individuals that have written on the work done by the disability community to demand accessible public bathrooms--identifying the anxiety “at the core of contemporary

---

<sup>17</sup> Ruth Barcan, “Dirty Spaces: Separation, Concealment and Shame in the Public Toilet,” *Toilet: Public Restrooms and the Politics of Sharing* ed. Harvey Molotch and Laura Norén (New York: New York University Press, 2010) 25-41.

<sup>18</sup> Barbara Penner, “Entangled with a User: Inside Bathrooms with Alexander Kira and Peter Greenaway,” *Toilet: Public Restrooms and the Politics of Sharing* ed. Harvey Molotch and Laura Norén (New York: New York University Press, 2010) 230-231.

encounters with difference” that has prevented architects, governments and able-bodied people from not only accommodating, but accepting disabled people as members of the public.<sup>19</sup>

Sociologist Spencer Cahill and his students used Erving Goffman’s concepts of “frontstage” and “backstage” behaviors to analyze the norms and “behavioral guidelines” witnessed in the public bathroom.<sup>20</sup> Teams of architects, designers and scholars, such as “Stalled!” have presented new models for public restrooms through legal initiatives, design proposals, and educational workshops, taking national debates surrounding transphobia and the public bathroom as “its point of departure” to address the need for “safe, sustainable and accessible public bathrooms...regardless of age, gender, race, religion and disability.”<sup>21</sup>

While this work--historic, political, scholarly and architectural--has encouraged progress in how public bathrooms are discussed and designed, such as the gradual shift towards gender neutral public bathrooms or the United States’ legally-mandated enlargement of bathroom stalls’ standardized dimensions, this thesis rests upon the belief that discussions on public bathrooms must be contextualized by this country’s histories with public infrastructure and architecture. Through this contextualization, the objectives behind the first public bathrooms, and the various forms of exclusivity and prejudice underlying these objectives, can help explain how the public bathroom has become a site engulfed by sociocultural tensions and confrontations today. By situating the public bathroom as a component of New York City’s urban history, the architecture that they have become known for, and the dynamics and behaviors that they have been known to foster, can be understood in connection to historical ideologies, beliefs and policies.

---

<sup>19</sup> David Serlin, “Pissing Without Pity: Disability, Gender and the Public Toilet,” *Toilet: Public Restrooms and the Politics of Sharing* ed. Harvey Molotch and Laura Norén (New York: New York University Press, 2010) 167-185.

<sup>20</sup> Spencer Cahill et. al, “Meanwhile Backstage: Behavior in Public Bathrooms,” *Urban Life* 14, no. 1 (1985): 33-58.

<sup>21</sup> “Stalled!” <https://www.stalled.online/>.



## **Outline**

I will begin this thesis by explaining how the need for public infrastructure, specifically water-supply and sewage systems, emerged in New York City during the 19th century. This history introduces various political, cultural and social trends from this period: the problematic approach city administrators took when first attempting to respond to public health crises, the racist and xenophobic stereotypes constructed by the white upper class in response to the rise in immigration, and the influence both of these moments consequently had on the concept of ‘hygiene.’ This chapter will rely upon the visual and historical analyses of both New York City’s first public bathhouse in 1891, known as The People’s Bath, and New York City’s first public comfort station in 1869 at Astor Place, both of which exemplify the materialization of classist, racist and xenophobic beliefs. This chapter also includes references to archival reports that exemplify how public bathrooms in New York City were first envisioned and discussed by groups such as the New York Association for Improving the Conditions of the Poor.

While the first chapter will introduce how public infrastructure and architecture became a means for regulating behavior and societal dynamics, the second chapter will discuss the influence that modern architecture had on the public bathroom and its methods of social control. This chapter will examine the various components and qualities of modern architecture that became integral to the public bathroom as we know it, centralizing the emphasis that modernity placed on standardization, efficiency and the notion of ‘whiteness.’ Through referencing the archival documentation of urban renewal projects led by former NYC Park Commissioner, Robert Moses, this chapter will illustrate how the architecture of public comfort stations was reimagined during the 20th century in response to societal and governmental impulses for modernity. The archival documents and site plans from this moment of reconstruction will be

contextualized alongside another 20th century development, the architectural handbook, which formally delineated the standardization of bodies into a ‘universal’ subject. These materials serve to demonstrate how and why the public bathroom transformed into the architectural typology we are now familiar with, and what government officials and architects believed would be gained from this model.

The first two chapters trace the history of public infrastructure and public comfort stations in New York City throughout the 19th and 20th centuries, while also noting how they were envisioned as tools of social and behavioral regulation. Architectural design facilitated the transformation of public bathrooms into sites of social control by symbolizing and materializing the beliefs and anxieties--regarding waste, unfamiliar bodies, gender and sexuality--that led to their inception. The final chapter will illustrate how, regardless of the rigid and consistent behaviors and dynamics that modern architecture hoped to produce, public bathrooms have repeatedly witnessed their reappropriation and reconfiguration by those that they were not designed for--such as disabled and trans people--and through actions that were never intended to take place there--such as sex. This chapter exemplifies how no piece of architecture is fixed or impermeable, but instead is continuously responding to the social period it finds itself in.

This thesis does not intend to declare that there is a ‘right’ and a ‘wrong’ way to design public bathrooms--though, it is safe to say that the standard we are accustomed to today is not working. Instead, this thesis illustrates how public architecture can be a form of symbolism that reveals how those behind its construction envisioned and characterized a public and, simultaneously, how these figures believe this public should behave and interact. This dynamic is intensified within the public bathroom because of this space’s sustained association with shame and embarrassment, therefore one’s behavior has been deemed particularly sensitive and

representative of broader sociocultural beliefs or conditions. This thesis posits that public bathrooms in the United States have been used as apparatuses of social control since the first was built in 1869, due to the relationship that this country has drawn between one's body, 'hygiene,' and morality.

## **Public Bathrooms as Public Health: From Epidemics, to Public Bathhouses, to the First Public Comfort Station**

“The idea of a healthy architecture is always about the health of a small group relative to multiple others, but is routinely made in the name of all.”

Mark Wigley, “Chronic Whiteness”

“Social concern with hygiene is inseparable from division of the population into high and low, and control of the lower orders.”

Alan Hyde, *Bodies of Law*

Today, public bathrooms are anticipated components of the built environment. Yet, they are often difficult to locate, restricted to shops and therefore, to customers, out of order, locked or simply non-existent. Across the United States, and particularly within New York City, it has become routine to grow frustrated when attempting to find a public bathroom. It has been translated into a failure to respond to or care about public need on the part of government officials, politicians, and architects. However, the origins of public bathrooms in New York City illustrate how they were never conceived of as acts of care or support. Public comfort stations were born out of the city’s first encounters with public health crises, and the consequential pressure that City officials and administrators felt to manage the City’s declining built environment and its struggling inhabitants. As the concept of public bathrooms emerged, they became entangled with notions of ‘hygiene,’ ‘morality,’ and ‘Americanness.’ Public comfort stations became one site of many where these concepts were not only developed, but enforced. Cities are molded by their past, and this does not exclude a space as seemingly utilitarian or futile as public bathrooms.

## Urbanization and the Initiation of Sanitary Services

Towards the end of the 18th century and into the 19th century, the pace of urbanization within cities across the U.S. quickened, causing greater influxes of immigration into the United States, particularly New York City. These simultaneous shifts within cities' social fabrics revealed the unsustainability of the United States' practice of urban privatism. Urban privatism asserted that the city was to "be an environment for private money-making, and its government was to encourage private business" and individual responsibility in general.<sup>22</sup> Therefore, cities relied upon individuals--as opposed to government officials or administrators--for maintaining their finances, resources and overall well-being. Urban privatism initiated the individualistic and self-reliant social culture of U.S. cities, particularly that of New York City.

One of the greatest impacts of cities' increasing population was the continual emergence of various deadly diseases and epidemics.<sup>23</sup> The daunting uncertainty and threat to life this caused required cities across the United States to reconsider the impacts that urban privatism was having on the exact elements it had served to protect: the economy, infrastructure and health of their cities. Epidemics became the catalyst for city administrators to realize that they were responsible for protecting their public, and that their cities' built environments were the means for doing so. The built environment, through both its infrastructure and architecture, became the liaison between a city's government and its public regarding public health concerns--though the development of this relationship was gradual.

Without yet having scientific or medical confirmation of the causes of or treatments for new epidemics and diseases, cities' regulation of public health relied upon visualizable and sensorial indications of 'dirtiness,' like "odors, smells, and putrefying wastes."<sup>24</sup> City

---

<sup>22</sup> Melosi, *The Sanitary City*, 18.

<sup>23</sup> *Ibid.*

<sup>24</sup> *Ibid.*, 20-21.

governments began to consider the consequences that ‘dirty’ city commons, or central streets and plazas, could have on the city’s overall health, and therefore its economy and prosperity. As the rise of immigration into New York City coincided with the emergence of novel illnesses, white, upper-class residents found it “simplest to blame the poor, the infern, or members of nonwhite races” for the turmoil affecting the city’s built and social environment.<sup>25</sup> Such accusations were supported by the evolving definition of ‘dirtiness’ as a sensorial trait involving odors; Black, immigrant and low-income communities were associated with the “sickening odors of the tenement-house,” though this was a symptom of infrastructural inequities rather than qualities of the inhabitants.<sup>26</sup> Though New York City was being forced to reconsider the benefits of urban privatism, the mentality that it had bred into upper-class New Yorkers was persistent. Rather than viewing the health conditions of tenement dwellers as a result of the city’s uneven and classist development of infrastructure and architecture, the inhabitants were deemed responsible for New York City’s struggles with public health.

Consequently, the first measure taken by the City of New York in response to public health concerns was the establishment of a city inspector in 1804; the role of this office was to monitor public nuisances and report any violations to the city council.<sup>27</sup> The formal incorporation of public health into administrative responsibilities was initiated through methods of surveillance and policing, most predominantly the surveillance and policing of tenement houses. The architecture and infrastructure of tenement houses remained inadequate, yet the sanitary conditions of its inhabitants were expected to improve through the threatening presence of an inspector. The relationship between the management of New York City’s public health crisis and methods of social control was reemphasized in 1865 with the creation of the first Municipal

---

<sup>25</sup> Melosi, *The Sanitary City*, 59.

<sup>26</sup> Renner, “A Nation That Bathes Together,” 504.

<sup>27</sup> Melosi, 20-21.

Board of Health, which included one health commissioner, one physician and three commissioners appointed by the governor, and most notably, four police officers.<sup>28</sup>

Throughout the 17th and 18th centuries, New York City's water-supply systems--mainly wells and pumps--had become insufficient in both scale and quality. The process and politics behind developing a clean and reliable water supply in New York City was influenced by the city's persistent privatist approach; the preference for establishing a private system, rather than a municipal one, was motivated by political and financial schemes. The Manhattan Company was founded in 1799 as New York City's first (privately-owned) water supply system by New York City Council Assemblyman Aaron Burr.<sup>29</sup> To found the company, Assemblyman Burr acquired a charter which would grant it with substantial power and few obligations--Burr had hoped to use the company's power to "amass surplus capital in the hopes of building a great banking business."<sup>30</sup> Administrative considerations of public infrastructure and public resources were inseparable from capitalist dreams, with little relevance to their public's needs, health or well-being. Consequently, the Manhattan Company laid only 23 miles of pipes, while also charging twenty dollars a year to those the pipes reached, asserting that access to clean water was limited to the upper class.<sup>31</sup>

The Manhattan Company's Reservoir was illustrated in a lithograph in the *Manual of the Corporation of the City of New York for 1855*. The architecture of this building reflects the company's prioritization of affluence and power, as opposed to the health and well-being of the public (Fig. 1.1). Tall and grand in size, composed of brick and stone materiality, with columns

---

<sup>28</sup> "1866 - The Metropolitan Health Act was passed in New York," *Historia Sanitaria*, <https://www.wiki.sanitarc.si/1866-metropolitan-health-act-passed-new-york-efforts-dr-stephen-smith-dorm-an-eaton-giving-adequate-power-health-authority-enforce-public-health-laws/>.

<sup>29</sup> "New York City's Water Supply System: Past, Present, and Future," *National Center for Biotechnology Information*, <https://www.ncbi.nlm.nih.gov/books/NBK566285/>.

<sup>30</sup> Melosi, *The Sanitary City*, 36.

<sup>31</sup> "Privatization, Part II: Hamilton, Burr, and the Manhattan Company," *Public Water*, <http://public-water.com/story-of-nyc-water/privatization-ii/>.

and legend-like sculptures upon the front-facing facade, this Reservoir exemplified many of the architectural elements used in ancient civilizations to indicate power.<sup>32</sup> The conceptualization and materialization of ‘power’ has always been interwoven with the existence of a ‘class society,’ therefore to demonstrate one group’s power architecturally is also to demonstrate “the violence of one class for suppressing another.”<sup>33</sup> As one of New York City’s first public resources, the Manhattan Company illustrated *which* public such resources were tailored to, both in how its service functioned and in the architecture it was represented by. Regardless of their intended upper-class clientele, the Manhattan Company’s infrastructure was carelessly constructed, often out of service and serving water unfit for consumption, becoming obsolete in 1842 with the introduction of the Croton Aqueduct.<sup>34</sup> The origins of New York City’s public health system and infrastructures reveal the city’s apathetic attitude towards public need and well-being, dealt with through methods of surveillance and the accumulation of profit.

---

<sup>32</sup> Mohsen Dehbozorgi, “Recognition of the Elements of Power in Ancient Architecture,” *Urban and Regional Planning* 1, no. 4 (2016): 97-104.

<sup>33</sup> Ibid.

<sup>34</sup> “Documentary History of American Water-Works,” *Waterworks History*, [http://www.waterworkshistory.us/NY/New\\_York\\_City/manhattan.htm](http://www.waterworkshistory.us/NY/New_York_City/manhattan.htm).





Figure 1.1: “Reservoir of Manhattan Water Works *Chambers St. 1825*,” *Manual of the Corporation of the City of New York*, lithograph, 1855.

### Cleanliness as Morality

In 1842, the same year the Old Croton Aqueduct was completed, New York City’s Inspector at the time, John Griscom, published the report, “A Brief View of the Sanitary Condition of the City.”<sup>35</sup> This report stressed a symbiotic relationship between a city’s and an individual’s physical and moral health; Griscom believed that by preventing disease and filth, “moral decay” could, too, be prevented, specifically referencing New York City’s Black, immigrant and low-income populations.<sup>36</sup> Conventions discussing public health and sanitation were held in different cities across the United States, circulating and solidifying the belief that

<sup>35</sup> Melosi, *The Sanitary City*, 61-62.

<sup>36</sup> *Ibid.*

“the evils which now bear so heavily upon the poorer classes already seriously endanger the sanitary safety of all other classes, and multiply the social perils and public burdens of the city.”<sup>37</sup>

The inadequacies of New York City’s built environment were still not considered to be the roots of the city’s public health crisis, instead perpetuating stigmas against non-white, non-rich communities by identifying them as the cause of much broader issues.

The rise of epidemics, access to a public water-supply system, and associations drawn between one’s physical and moral condition all became further intertwined when scientists confirmed “the germ theory” in 1880.<sup>38</sup> The “germ theory” discovered that most diseases were waterborn, a realization with two major impacts. First, the “germ theory” enacted the medicalization of cleanliness into the concept of “hygiene,” emphasizing bathing oneself “as a curative for illness.”<sup>39</sup> Since landlords continuously neglected to update or maintain the architecture and infrastructure of tenement houses, they often lacked bathing facilities.<sup>40</sup> This sustained the upper-class’s mistrust towards tenement house residents, since “unwashed members of society” were viewed as “a potential threat to the larger community.”<sup>41</sup> ‘Cleanliness’ had become “a sign of refinement, virtue, and personal responsibility” and, more broadly, “part of the normative discourse surrounding ‘Americanness,’” without proper consideration over the various barriers that prohibited certain New Yorkers from achieving this model of ‘cleanliness.’<sup>42</sup> As a result, the New York Board of Health, New York medical doctors, and the white upper class all believed that New York City, specifically its Black, immigrant and low-income communities, needed public bathhouses so as to produce “good Americans.”<sup>43</sup>

---

<sup>37</sup> Ibid.

<sup>38</sup> Ellen Lupton, *The Bathroom, the Kitchen, and the Aesthetics of Waste* (New York: Princeton Architectural Press, 1992), 23.

<sup>39</sup> Ibid., 17-18.

<sup>40</sup> Julie Horan, *The Porcelain God: A Social History of the Toilet* (Secaucus: Carol Publishing Group, 1997): 99.

<sup>41</sup> Lupton, *The Bathroom, the Kitchen, and the Aesthetics of Waste*, 19.

<sup>42</sup> Renner, “A Nation That Bathes Together,” 506.

<sup>43</sup> Ibid.

Whereas the architecture of public bathhouses in European cities relied upon “lavish displays of civic pride,” the architectural design of the first public bathhouses in New York City was intended to be “clean, orderly, and respectable.”<sup>44</sup> Public bathhouses were mainly constructed in immigrant communities and neighborhoods, and were racially segregated.<sup>45</sup> Therefore, though European immigrants were stigmatized and ostracized for lacking ‘American’ values and traits, their whiteness distinguished them from Black New Yorkers, materializing the perpetuation of white supremacist attitudes into the built environment. In 1891, The People’s Bath was the first public bathhouse constructed in New York City.<sup>46</sup> By 1915, nineteen public bathhouses had been established throughout the urban built environment (Fig. 1.2). The site plan of The People’s Bath was replicated at later locations, therefore it can be used to represent the design of public bathhouses across New York City.

---

<sup>44</sup> Ibid., 510.

<sup>45</sup> Marilyn Williams, *Washing “The Great Unwashed”: Public Baths in Urban American, 1840-1920* (Columbus: The Ohio State University Press 1991), 61.

<sup>46</sup> Ibid.

**MAP 1**  
**The Public Baths of Manhattan, 1915**

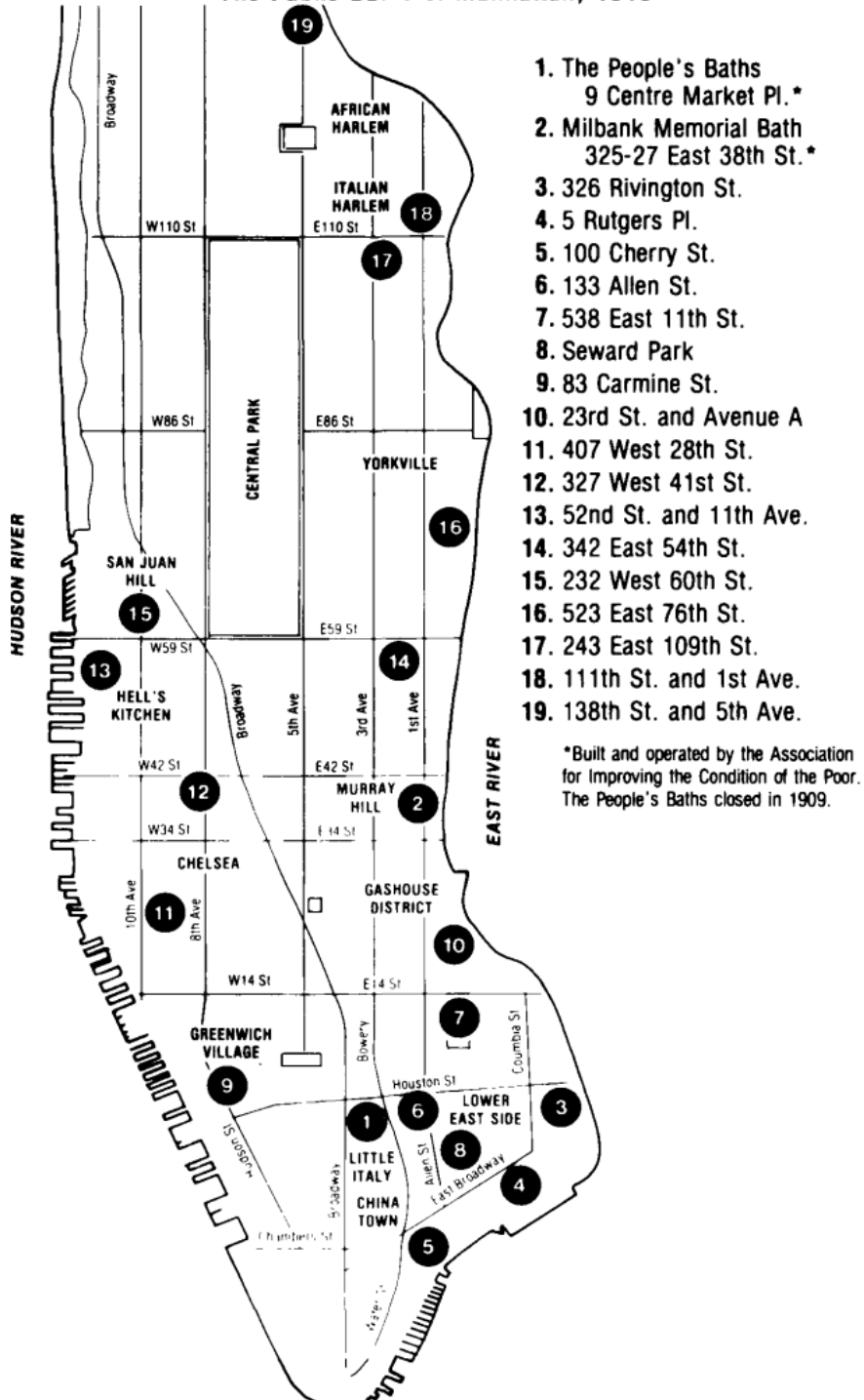

Figure 1.2: "Map 1, The Public Baths of Manhattan, 1915."

The sustained commitment to the site plan of the People's Bath was likely due to its enforced regulation of the bathing process, designed so as to enact the "cultivation of the habit of personal cleanliness" among those within.<sup>47</sup> At the same time, public bathhouses grew in popularity in New York City during the late 1890s and early 1900s due to what city administrators at the time believed was the "new social spirit or the civic renaissance, whereby the claims of life are given precedence over those of property."<sup>48</sup> As diseases continued to circulate and populations continued to grow, city administrators and officials had to face the fact that their cities had to become "more of a home for all members of the body politic," and that the newly arriving members of the city's social fabric were not temporary. One way of accommodating these new members of 'the body politic,' it was believed, was by making bathing and bathroom facilities publicly accessible.<sup>49</sup> The 'claims of life' within this 'civic renaissance' took form by enforcing bathing practices upon Black, immigrant and low-income communities.

### **Designing 'Hygiene'**

The site plan of the People's Bath enabled one singular path of circulation, which began by entering either through the men's or women's entrance, followed by a supervised, single-sex waiting rooms (Fig. 1.3, 1.4, 1.5).<sup>50</sup> After waiting their turn in either the men's or women's waiting rooms, guests had twenty minutes to use either the shower or bath, after which they had to leave the building immediately. A central office space was placed in between each waiting room, separated from them through a "partition of glass and ornamental iron, so located that...no

---

<sup>47</sup> *Report on Public Baths and Public Comfort Stations by the Mayor's Committee of New York City* (1897): 18.

<sup>48</sup> *Ibid.*, 26.

<sup>49</sup> *Ibid.*

<sup>50</sup> Renner, "A Nation That Bathes Together," 519.

one can enter or leave the buildings, or its baths, without being seen from this point.”<sup>51</sup> This attunement to surveillance within New York City public bathhouses’ structure and materiality is reminiscent of Bentham’s social control mechanism from the mid-1700s, the panopticon, characterized as the “comprehensive symbol for modern authority and discipline in the western world.”<sup>52</sup> The panopticon was initially designed to monitor the maximum number of prisoners with the least amount of guards and security costs; this undertaking was completed through a central tower surrounded by a ring-shaped building of prison cells.<sup>53</sup> Similarly, New York City’s public bathhouses were designed so that a single, stationed officer or attendant could supervise and control the entrance and movement of everyone within--noted for its economical benefits since, at any point, just one person could “control all parts of the building.”<sup>54</sup> Though the guests of public bathhouses were not prisoners and the bathhouse was not a prison, the architecture of this space evidently drew upon developing, Western understandings of authority, discipline and control.

Michael Foucault has discussed how the “continuous surveillance and the feeling of general visibility” that the panopticon enacted was capable of “coercing internal moral reform by making a person feel as though they were constantly being watched.”<sup>55</sup> According to this analysis, it is understandable why a similar design was incorporated within New York City’s first public bathhouses, which were primarily constructed to induce ‘moral reform’ from those within via bathing. Further, Foucault noted that “when architecture disciplines, it does not matter who

---

<sup>51</sup> *Report on Public Baths and Public Comfort Stations*, 165.

<sup>52</sup> “Internalized Authority and the Prison of the Mind: Bentham and Foucault's Panopticon,” *Joukowsky Institute for Archaeology & the Ancient World*, [https://www.brown.edu/Departments/Joukowsky\\_Institute/courses/13things/7121.html](https://www.brown.edu/Departments/Joukowsky_Institute/courses/13things/7121.html)

<sup>53</sup> Rajiv C. Shah and Jay P. Kesan, “How Architecture Regulates,” *Journal of Architectural and Planning Research* 24, no. 4 (2007): 350-359.

<sup>54</sup> *Report on Public Baths and Public Comfort Stations*, 65.

<sup>55</sup> *Ibid.*

exercises power. Any individual, taken almost at random, can operate the machine.”<sup>56</sup> Therefore, according to this logic, while public bathhouses hired and stationed a specific individual to monitor those within, any person at any point could take on that role--causing those around them to feel watched and examined, circulating a constant sense of visibility. The flexible authorization of power that the panopticon model enabled assisted the beliefs that led to the development of public bathhouses in the first place--namely, the belief that controlling others’ treatment of their bodies could improve a city’s health, ‘hygiene’ and morality. Public bathhouses were designed around this intended social regulation, encouraging those within to both feel observed, while also observing those around them.

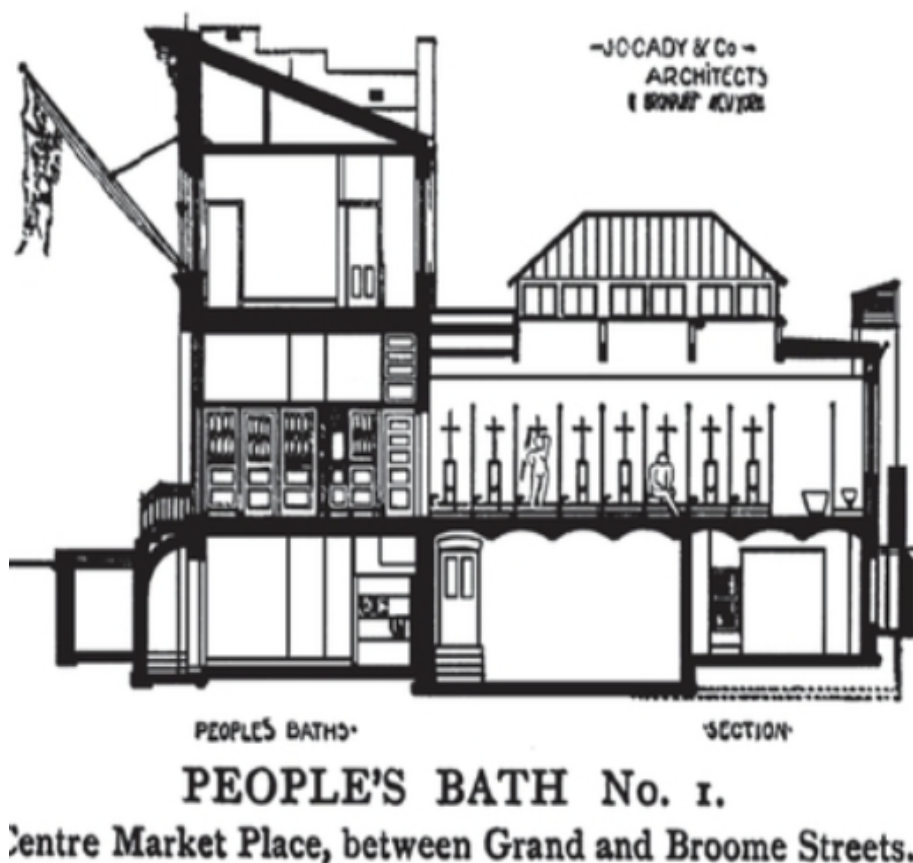

Figure 1.3: J.C. Cady & Co., “People’s Bath No. I.,” section drawing, 1891.

<sup>56</sup> Shah and Kesan, “How Architecture Regulates,” 354.



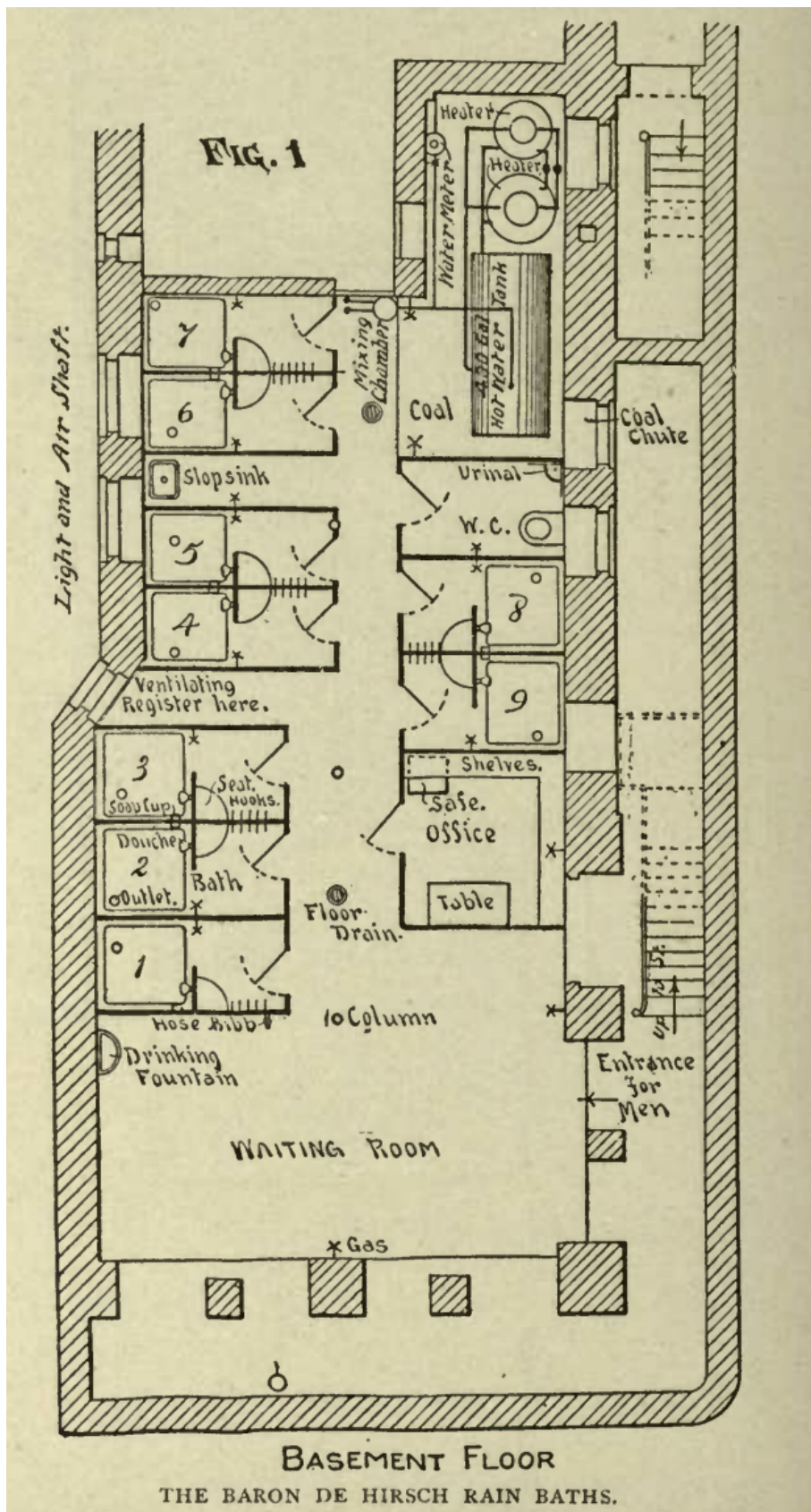

Figure 1.4: Brunner & Tryon Architects, “The Baron De Hirsch Rain Baths,” site plan of men’s section on the basement floor, 1891.



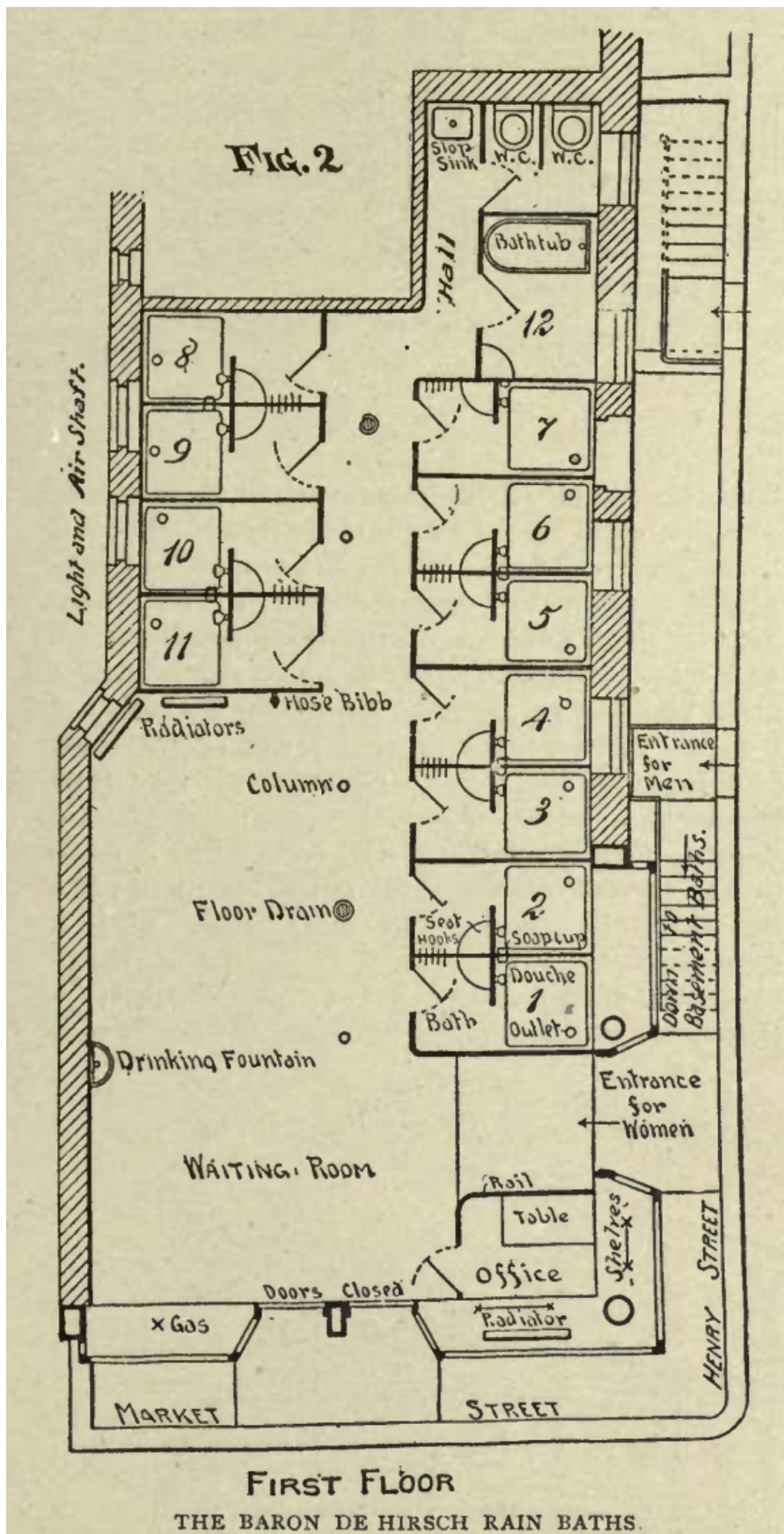

Figure 1.5: Brunner & Tryon Architects, "The Baron De Hirsch Rain Baths," site plan of women's section on the first floor, 1891.

While the site plan of the People's Bath was structured and shaped by disciplinary intentions, the architectural design more broadly can, similarly, be analyzed and understood. Utilizing light-colored brick and terracotta for both the exteriors and interiors of New York City's public bathhouses was meant to inspire guests' preferences towards cleanliness, minimalism and purity while also being "modest" enough so as to "not repel the poor and lowly by architectural pretensions," yet still possessing "the dignity and massiveness necessary to prevent its appearing insignificant or trivial" (Fig. 1.6).<sup>57</sup> Within the interiors, windows, skylights and reflective surfaces were installed to "everywhere suggest cleanliness and light, and no possibility of hidden disease germs."<sup>58</sup> Cement, iron, slate and enamel constructed the bathing halls--quick to produce and easy to clean--which were lined by stalled compartments (Fig. 1.7).<sup>59</sup> In stark contrast to the luxury and relaxation that was designed into the domestic bathrooms of the upper class, public bathhouses centralized bare, minimal designs so as to hyper emphasize their cleanliness, both to assure guests and to impart them with an internalization of 'hygiene' practices.

The architectural design of the first public bathhouses "inhibited the communal," intentionally designed to produce isolated, independent interactions as opposed to encouraging congregation or socialization.<sup>60</sup> Alongside the "germ theory" initiating public bathing and 'hygiene' practices, this theory simultaneously instituted a fear of others' bodily waste, as it was now a confirmed, potential means of germ (and illness) transmission. This theory authorized the discomfort of the white upper class towards the potentially 'dirty' bodies of others, specifically towards Black, immigrant and low-income communities. The design of the first public

---

<sup>57</sup> Renner, "A Nation That Bathes Together," 510, 513.

<sup>58</sup> *Report on Public Baths and Public Comfort Stations*, 168.

<sup>59</sup> Renner, 511.

<sup>60</sup> *Ibid.*, 520.

bathhouses motivated this discomfort among other demographics, by deliberately keeping bodies separated through stalls and time limits.



Figure 1.6: J.C. Cady & Co., "People's Baths," photograph, 1891.

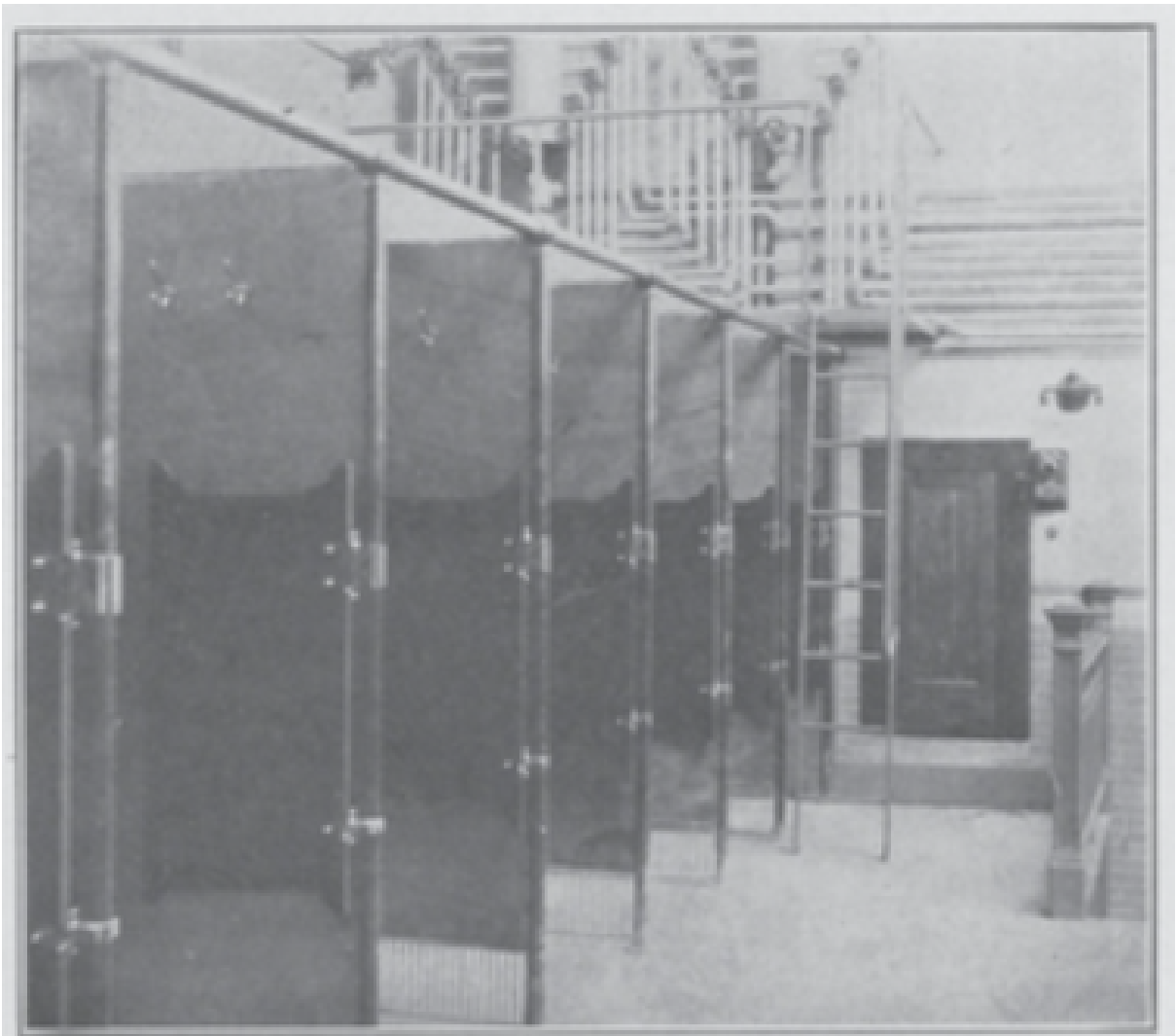

Figure 1.7: Werner & Windolph, “West 60th Street Baths,” photograph, 1906.

### **Bodily Waste as Societal Threat**

Prior to the confirmation of the “germ theory” in the United States, human waste remained under the branch of ‘public nuisances,’ so waste disposal had been an individual responsibility. Individuals were in charge of disposing of their waste in open lots or cesspools near their house, as well as for periodically emptying them.<sup>61</sup> City governments’ disregard for establishing a municipal waste disposal system illustrates a broader dismissal across the United

---

<sup>61</sup> Melosi, *The Sanitary City*, 41.

States of creating adequate services for natural, biological processes such as urination, defecation, or menstruation to occur safely and comfortably. This may be attributed to the long-standing association between the human body and human waste with shame or embarrassment rather than acceptance and accommodation, or to the recurring characterization of waste-disposal systems and infrastructure as unimportant. For New York City to switch their waste disposal systems from being separate and individualized to being public and municipal required proof that such an approach would “provide benefits not derived from the old one.”<sup>62</sup> The “germ theory” introduced fears and associations between human waste and illness that highlighted the benefits of a municipal waste disposal system, and the risks of continuing to rely on individual responsibility.

As public bathhouses could remove and sanitize “the unwanted elements from the body,” sewage, drainage and public toilet systems could bring “technologies of concealment” into the built environment, invisibilizing human waste.<sup>63</sup> Throughout this period of the 1800s, bodily restraint was regarded as “essential to respectability” by the urban, white middle and upper class, therefore the presence of waste within public streets made New York City’s status, and therefore the status of its inhabitants, questionable.<sup>64</sup> In 1857, New York City’s waterworks engineer developed the first effective city-wide sewage system.<sup>65</sup> The dangers and illnesses that bodily waste could potentially cause placed further pressure on individuals to behave and appear ‘hygienically’ in public, escalating the “individualization of the self and a concomitant retreat into well-separated, bounded, and sealed bodies,” a process motivated by the design of public bathhouses, yet which also built off New York City’s social history of individualism.<sup>66</sup>

---

<sup>62</sup> Ibid., 91-94.

<sup>63</sup> Renner, “A Nation That Bathes Together,” 605; Barcan, “Dirty Spaces,” 34.

<sup>64</sup> Baldwin, “Public Privacy: Restrooms in American Cities, 1869-1932,” 267-268.

<sup>65</sup> Melosi, 93.

<sup>66</sup> Barcan, “Dirty Spaces,” 34.

In 1865, New York physicians conducted a study of New York City, the *Report of the Council of Hygiene and Public Health of the Citizens' Association of New York Upon the Sanitary Condition of the City*, which included a specific call for public urinals and comfort stations in response to complaints over men urinating in the city's streets and the continuing public health crises. As a response, the Metropolitan Board of Health proposed the construction of two public comfort stations "in heavily traveled areas" one at Park Row and Broadway near City Hall and a smaller one at Astor Place.<sup>67</sup> Limited by a \$3,500 budget, only the comfort station at Astor Place was constructed, opening in May of 1869. Public comfort stations, the predecessor to public bathrooms, were therefore the symptom of various sociocultural themes: the determined interdependence between the city's 'cleanliness' and its inhabitants' well-being, the association between bodily waste and illness, and a gradual acceptance by the New York City government of its residents' needs.

While New York City administrators and politicians had begun to realize the need for public comfort stations during the late 1800s and early 1900s, many members of the public remained reluctant. On the one hand, middle- and upper-class white New Yorkers appreciated public comfort stations for reducing "the filth and indecency of the street" and encouraging city-wide bodily restraint, which they had deemed "essential to respectability" and 'morality' throughout the 19th century.<sup>68</sup> On the other hand, however, disinterest and disapproval towards public comfort stations or public urinals was strong; many merchants and business owners firmly opposed the installation of either, "fearing that the odor and appearance would repel affluent people who were their most valued customers."<sup>69</sup> Other objectors, however, simply believed that public comfort stations would disrupt the "harmonious appearance of nearby buildings" by being

---

<sup>67</sup> Baldwin, "Public Privacy: Restrooms in American Cities, 1869-1932," 268.

<sup>68</sup> *Ibid.*, 267.

<sup>69</sup> *Ibid.*, 269.

an “eyesore.”<sup>70</sup> Though public comfort stations were becoming associated with moral and physical benefits on both individual and societal scales, concerns over the potentially damaging aesthetics of public comfort stations--because of people’s intense discomfort with being in close proximity to waste--sustained societal reluctance.

Architects, planners and city administrators deemed ornament to be the response. Throughout reports and surveys conducted by New York City administrators regarding public bathhouses and comfort stations, the importance of the structures’ attractiveness was emphasized. Attractiveness was deemed crucial both to “bring up the sense of decency in the users than degrade it” and to “introduce among our lowest classes habits of cleanliness and self-respect.”<sup>71</sup> A connection was drawn between public comfort stations’ ornament and their reception and acceptance, similar to how the architecture of the first public bathhouses was designed in order to produce and condition certain mentalities and practices. During this period of the mid to late 19th century in New York City, cast-iron had become one of the most popular architectural materials, “which reflected the popular taste in its demand for...ornament.”<sup>72</sup> Cast-iron was capable of “finer sharpness of outline, and more elaborate ornamentation and finish” than other materials used for ornamentation, such as marble or stone--yet, most importantly, it was a cheaper material, and therefore could be “placed within the reach of those who desire to gratify their own love of art, or cultivate the public taste.”<sup>73</sup> Cast-iron ornamentation had become favored both by architects and the ‘public taste,’ therefore becoming a useful device for making public comfort-stations’ introduction into the built environment slightly more seamless.

---

<sup>70</sup> Alexander Davis, *Bathroom Battlegrounds: How Public Restrooms Shape the Gender Order* (Oakland: University of California Press, 2020), 53.

<sup>71</sup> *Report on Public Baths and Public Comfort Stations*, 143.

<sup>72</sup> W. Knight Sturges, “Cast Iron in New York,” *The Architectural Review* 114 (October 1953): 234.

<sup>73</sup> *Ibid.*

As has been stated by various scholars, “architecture plays a communicative role by expressing cultural or symbolic values.”<sup>74</sup> Cast-iron ornamentation, then, represented one method for New York City administrators, officials and architects to communicate to their public that comfort stations were a new societal and cultural value. Simultaneously, architects’ acknowledgment that cast-iron ornamentation was part of the ‘public taste’ suggests that its incorporation into public comfort stations was an attempt at gaining the public’s acceptance of their construction. In response to the hesitation and discomfort that the concept of public bathrooms first evoked--primarily amongst the middle and upper class--societal aesthetic preferences were tailored to. New York City’s first public comfort stations incorporated ornate entrances, signage and lighting fixtures, trying to aestheticize spaces that would have otherwise been associated with shame and distaste.

The architecture of the first public comfort station at Astor Place can be explained by various, conflicting 19th-century sociocultural beliefs. On one hand, constructing a public bathroom was seen as a way to universalize upper-class, domestic hygiene practices so that low-income and working class communities could “find acceptance within middle- and upper-class society and for immigrants to demonstrate that they had fully assimilated to native-born culture.”<sup>75</sup> On the other hand, public bathrooms could be designed to reassert class boundaries by offering the public a space substantially less comfortable, aesthetically pleasing and orderly than those private businesses had simultaneously begun to offer shoppers.<sup>76</sup> Whereas 19th-century privately-owned restrooms, such as those within department stores, “attempted to replicate the private home in appearance and exclusivity,” offering luxurious and superfluous furnishing and amenities, the “instrumentalities” of public restrooms were “eminently

---

<sup>74</sup> Shah and Kesan, “How Architecture Regulates,” 351.

<sup>75</sup> Davis, *Bathroom Battlegrounds*, 31.

<sup>76</sup> Baldwin, “Public Privacy: Restrooms in American Cities, 1869-1932,” 271-274.



educational.”<sup>77</sup> While there were various intentions motivating the first public comfort stations, each led to an architectural design that reflected the intended guest’s identity back at them--emphasizing either their race, gender, class or nationality, just as the first public bathhouses had intended to.

The Astor Place public comfort station initiated the standards and societal expectations for public bathroom design. Throughout the research for this thesis, requests and inquiries regarding images or site plans of this comfort station--made to various archives--were unsuccessful. Though the New York City municipal archives include a multitude of documents and images, it appeared as though there was no documentation of the construction of the city’s first public bathroom, perhaps residue from the embarrassment and discomfort that saturated such a project or to the unimportance attributed to it. However, the verbal descriptions from reports and articles help in envisioning how this space was architecturally designed.

The small facility at Astor Place, constructed with cast iron walls, was divided into two sections--the men’s and women’s compartments. As the City’s first public bathhouses did, public comfort stations drew upon the societally assumed necessity for men and women to complete certain functions and processes separately. The men’s compartment was directly accessible from the street and contained three, stalled urinals and two toilets.<sup>78</sup> The women’s compartment was only accessible via an anteroom, or a vestibule-like space, that was primarily the janitor’s storage space and offered merely two stalls and one washbasin. Whereas the men’s compartment allowed guests to quickly slip into and out of the comfort station, their movement concealed by the business of the street, the women’s compartment’s structure ensured guests “were in plain view of hundreds of strangers as they entered and left the building,” the anteroom spotlighting their

---

<sup>77</sup> Ibid.

<sup>78</sup> Ibid., 268.

presence to the street.<sup>79</sup> Likely, this contrast was due to providing women access within urban public spaces being an afterthought--at this point of the 19th century, white women were still mainly confined to domestic spaces, and women of color to spaces of labor. Simultaneously, the complaints regarding the city streets being filthy were mainly a response to men urinating in public. Both of these elements led to a public comfort station that predominantly catered to men.

The cramped, small size of the space made it inaccessible to anybody with physical disabilities. The development of public ‘sanitary’ spaces in the 19th century had encouraged a culture of social disposability within New York City; as this period instituted the authorization and institutionalization of bathing, as formerly referenced through the People’s Bath, it also witnessed the institutionalization of disabilities.<sup>80</sup> ‘Dirty’ bodies needed to be ‘cleansed’ in order to participate and be accepted in public life, otherwise they would worsen the conditions of the city. Similarly, disabled people were excluded from public spaces, institutionalized, and ultimately “sterilized” as they were otherwise considered to be “wasteful drains on family and societal resources.”<sup>81</sup> The dismissal and exclusion of disabled people in the Astor Place public comfort station was one result of the broader “prescription, maintenance, and deployment of ability norms...and the production of the normate citizen” in the United States during the 19th century.<sup>82</sup> This century witnessed various forms of exclusion and social control across the built environment, in which architecture was used by government officials and administrators to indicate who the public constituted and how this public was expected to behave and regard itself.

The Astor Place public bathroom was torn down in 1872, three years after its construction, once the Department of Public Works took over its management and determined it

---

<sup>79</sup> Ibid., 269.

<sup>80</sup> Stephanie Jenkins, “Constructing Ableism,” *Genealogy* 5 no. 66 (2021): 5.

<sup>81</sup> Ibid.

<sup>82</sup> Ibid., 2.

was “in too public a place.”<sup>83</sup> The association between urination, defecation and shame was resistant to the attempted normalization of public bathrooms--their public presence was still deemed inappropriate. Though it was in service for only a few years, the architectural design of the Astor Place comfort station illuminates broader sociocultural trends that were developing throughout the 19th century. For example, the construction of two sections--one for men, one for women--is one reverberation of the United States’ historic tendency to “trace two clearly distinct lines of action for the two sexes.”<sup>84</sup> This tendency was particularly stressed within spaces of revelation, such as public bathhouses and comfort stations, in which it was established that the modesty of women was to be protected from men.

However, the United States’ tendency to separate people according to a gender binary was limited to white people. Jim Crow laws, which started being enforced in 1870, led to the racial segregation of public bathrooms; while white people had men’s and women’s sections, Black people and people of color were only granted a ‘colored’ section (Fig. 1.8). Public comfort stations’ initiation was influenced by concepts of ‘modesty’ and ‘purity’ that were constructed and circulated by the white upper class; therefore, the racial segregation of bathrooms was believed to ensure “that Black people would not contaminate bathrooms used by whites.”<sup>85</sup> However, the lack of recognition of gender within the ‘colored’ section of public bathrooms also exemplifies “civilizational discourse” at work; white people believed that the gender binary “was crucial in distinguishing civilized societies from the less advanced,” therefore the eradication of gender within the ‘colored’ public bathroom insinuates that white people did not regard Black people and people of color as firstly, members of the same society as them, and secondly, as

---

<sup>83</sup> Baldwin, “Public Privacy: Restrooms in American Cities, 1869-1932,” 268.

<sup>84</sup> Alexis de Tocqueville, *Democracy in America*, vol.4 (London: Saunders and Otley, 1840), 99.

<sup>85</sup> Toby Beauchamp, *Going Stealth: Transgender Politics and U.S. Surveillance Practices* (Durham: Duke University Press, 2019), 85.

civilized.<sup>86</sup> This perception and treatment of the gender binary demonstrates how the United States has employed constructed social categories within the built environment, in order to control and regulate its public.



Figure 1.8: 'Ladies,' 'Men,' and 'Colored' entrances to public bathroom, photograph, 1960.

The Astor Place public comfort station represents how New York City's public bathrooms came as the result of white, upper-class concerns over immigration, public health and the city's 'morality'--all of which initiated an architectural typology that centralized identity and visibility and, in turn, social and behavioral control. The architectural design of the Astor Place public comfort station represents how architecture was used to mediate the wary initiation of public bathrooms into public space, and how certain New York City residents were excluded or

---

<sup>86</sup> Ibid.

regulated in the process. Though initially, the white upper class was hesitant to welcome public comfort stations into the city's built environment, they gradually began to reconceptualize the space as one for pedagogy that could teach Black, immigrant and low-income communities 'hygiene' practices. The evolution of public bathrooms throughout the 20th century involves architectural developments that, ultimately, intensified former decades' control and standardization of the body in public, a process supported by the century's simultaneous development of the modern architecture movement.

## **Constructing a Standard: Modern Architecture's Influence**

“In all great epochs of history the existence of standards--that is the conscious adoption of typeforms--has been the criterion of a polite and well-ordered society; for it is commonplace that repetition of the same things for the same purposes exercises a settling and civilizing influence.”

Walter Gropius, *On the Bauhaus*

While the first public bathhouses (and the first public comfort station) of the 19th century were deemed necessary for improving the health, ‘hygiene,’ and ‘morality’ of Black, immigrant and low-income populations, during the 20th century, “wide-ranging pleas to consider the public good were simply less effusive and elaborate than odes to modernity.”<sup>87</sup> This did not mean that the public bathroom was no longer seen as an essential tool for conveying the importance of ‘hygiene’ throughout the city’s streets--on the contrary, it became transformed into a *modern* tool for advancing this agenda further. The development of modern architecture and standardization went hand-in-hand; the latter enabled the former to be erected using quicker, and therefore cheaper, materials and labor. In order to modernize the public comfort station--as the conclusions and critiques from two photographic and archival surveys from 1914 and 1934 suggest had to be done--it needed to become standardized.

Throughout the 20th century, many architects in the United States felt that there was no architectural model “appropriate to modern life” in their country.<sup>88</sup> While the quality of being ‘modern’ can be defined in a range of ways, within spheres of U.S. architectural discourse, modern life was characterized as “mobile, swift, dynamic,” with free movement from place to place, time “weighed as never before.”<sup>89</sup> Consequently, modern architects throughout the country

---

<sup>87</sup> Davis, *Bathroom Battleground*, 73.

<sup>88</sup> Alan Colquhoun, *Modern Architecture* (Oxford: Oxford University Press, 2002), 40.

<sup>89</sup> William Lescaze, “The Meaning of Modern Architecture,” *The North American Review* 244, no. 1 (1937): 110.

aimed to encapsulate such traits by replacing old methods of production and construction with newer and faster methods that were ‘of the time.’ During this same period of the 20th century, the white upper class grew increasingly adamant that public comfort stations were a necessary and crucial element of the urban built environment. The public bathroom became entangled with understandings of modernity during this century, ultimately evolving into a product of modern architecture.

During the 1910s and 1920s, many modernist architects and theorists began to align modernity with the notion of ‘hygiene.’ Adolf Loos in “Plumbers,” stated that “one of the fundamental tenets of modernism is its image of hygiene, its ideal of bringing cleanliness and order to the great unwashed,” moreover personifying modernism as a purifier over those perceived to be ‘unwashed.’<sup>90</sup> Hermann Muthesius, another proponent of modern architecture, once wrote of the bathroom as “an art based on actual modern conditions and modern achievements.”<sup>91</sup> These proclamations reflect a wide-spread understanding within the architectural community that to be modern, one had to begin at the bathroom. While these architects were not the figures designing public comfort stations in New York City--as they were referencing the domestic bathroom, rather than the public bathroom--their characterizations of hygiene and bathrooms as central components to modernism were influential over how public comfort stations were later conceptualized and designed.

Bathrooms, along with other buildings being deliberated within modernist discourse, were to be guided by “functional order,” or, designed around the functions that were intended to be conducted within so that they could be facilitated and “performed in the best possible

---

<sup>90</sup> Jan Jennings, “Le Corbusier’s ‘Naked’: ‘Absolute Honesty’ and (Exhibitionist) Display in Bathroom Settings,” *Interiors* 2, no. 3 (2011): 310.

<sup>91</sup> Penner, *Bathroom*, 108.

manner.”<sup>92</sup> While, arguably, public comfort stations were always designed around their function, since they served a fairly straightforward purpose, the lack of consistency across the design of New York City’s public comfort stations during the late 19th century frequently led to disorder. Comfort stations varied in their layouts, fixtures and materialities; while some were functional, others were still reliant upon antiquated fixtures and materials that made their usage nearly, or entirely, dysfunctional. Furthermore, the functions of the public comfort station were becoming interwoven with the functions of modernity during this period, consequently prompting a reevaluation of the treatment of, and behavior around, waste. To ensure that a building’s form was consistently directly responding to its function--and that this form was encouraging and exemplifying ‘modern’ completions of these functions-- its form was to be standardized, a template for the architectural toolbox.

### **The Desire for Modernism**

The New York Association for Improving the Condition of the Poor, which funded the city’s first public bathhouse discussed in the previous chapter, had a Department of Social Welfare, under which there was a Bureau of Public Health and Hygiene. In 1914, the Bureau felt compelled to conduct a “social, sanitary, and economic survey” on comfort stations in New York City out of “logical interests...in problems of disease causation and transmission, of sickness prevention, and of health preservation.”<sup>93</sup> Public comfort stations were deemed an “inviting field for study...fertile of results providing modern sanitary methods.”<sup>94</sup> Consequently, this survey studied certain phases of public comfort stations’ “construction, equipment and operation,”

---

<sup>92</sup> Lescaze, 113.

<sup>93</sup> New York Association for Improving the Condition of the Poor, *Comfort Stations in New York City: A Social, Sanitary and Economic Survey* no. 80 (1914): 11.

<sup>94</sup> *Ibid.*



culminating in 18 major recommendations. This report demonstrates the upper-classes' sustained association between the condition of the 'poor' and their need for public sanitary services, as well as the developing relationship between public comfort stations and 'modern' methods of sanitation.

Defined as a charitable organization, the New York Association for Improving the Condition of the Poor was funded solely through voluntary contributions and was aimed at systematizing charity throughout New York.<sup>95</sup> Therefore, though the Bureau did not explicitly address any specific party or government agency within its investigation, this survey can be seen as one component of a broader message to the City of New York regarding poverty and the role of the upper class. Their recommendations advise that those "conducting public comfort stations" recognize "the responsibility which they have for educating the people who come in contact with these stations," to induce "an appreciation of the necessity for sanitary equipment."<sup>96</sup> This survey may have been addressed to a variety of figures, from government officials that controlled the funding of comfort stations, to the architects and planners that were hired by these various officials to construct them. Regardless, it is clear that this Bureau saw a relationship between comfort stations, educating the 'poor' public, and public health, and intended to explicitly convey this linkage to those it pertained to.

The 1914 Survey's recommendations range from: suggesting opening public comfort stations in certain subway stations, renovating and redesigning those that already exist in subway stations and parks, and reappropriating public bathhouses into public comfort stations. They also offered direct advice to parts of New York City administration. They specifically advised the Department of Public Works to construct "smaller stations with fewer units, scattered over more

---

<sup>95</sup> "New York Association for Improving the Condition of the Poor. Office of the Corresponding Secretary and General Agent," *SNAC Cooperative*, <https://snaccooperative.org/view/32319533>.

<sup>96</sup> *Comfort Stations in New York City: A Social, Sanitary and Economic Survey*, 10

thickly populated areas, at more frequent intervals,” as well as providing proposals specific to the design of public comfort stations. Generally, the survey sought to improve both the presence and effectiveness of public comfort stations in order to popularize ‘hygiene’ practices. The specific materialization of this imagined and desired effectiveness coincided with many of modern architecture’s cries--namely that of form precisely following function. To the New York Association for Improving the Condition of the Poor, the function of public comfort stations was considered both educational and hygienic, and therefore, so should be the form.

One of the most significant criticisms that this survey offered regarded the discrete nature of public comfort stations. Their construction did not only need to widely expand, but they needed to embody the prominence of a public service announcement. The survey’s suggestions attempted to integrate both of these functions: public hygiene practices and public education. Their notes addressing the architectural obscurity of public comfort stations referenced their signs which were deemed “entirely too inconspicuous or lacking altogether.” (Fig. 2.1, Fig. 2.2.)<sup>97</sup>.

---

<sup>97</sup> *Comfort Stations in New York City: A Social, Sanitary and Economic Survey*, 16.



Figure 2.1:  
New York  
Association  
for Improving  
the Condition  
of the Poor,  
“No Sign!  
What Is It?  
Male Or  
Female?”  
Photograph,  
1914.

**NO SIGN! WHAT IS IT? MALE OR FEMALE?**

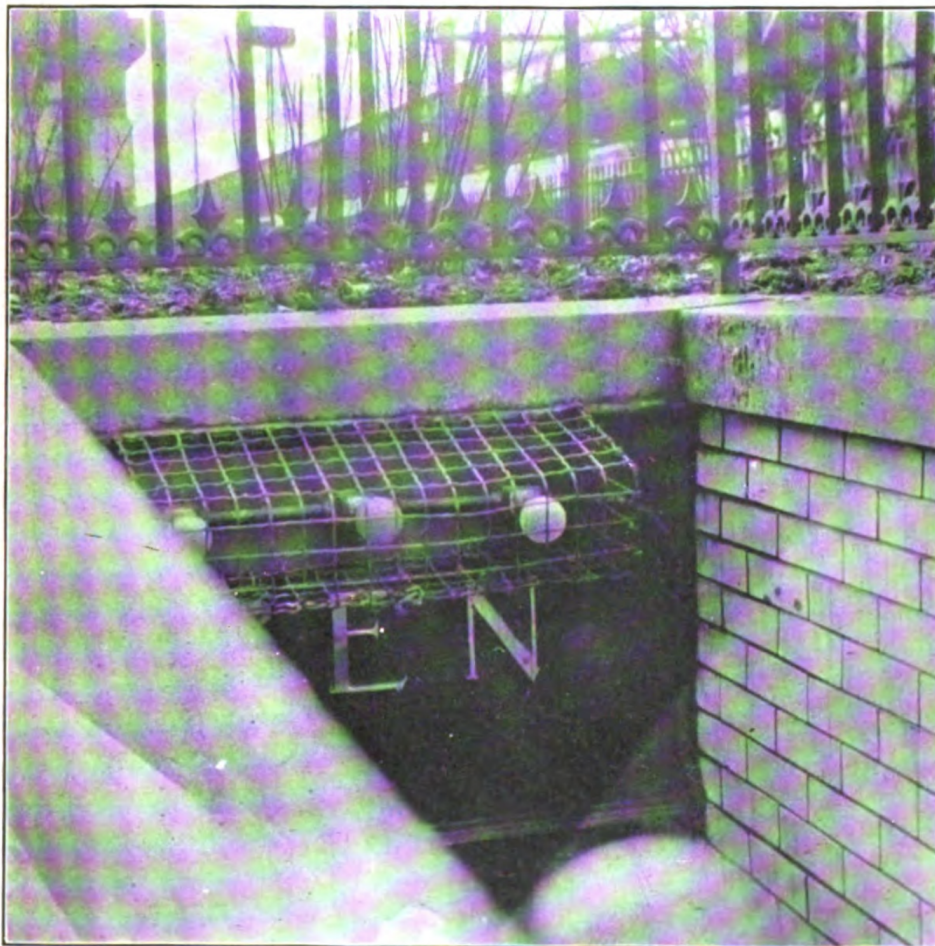

Figure 2.2:  
New York  
Association for  
Improving the  
Condition of  
the Poor,  
Photograph,  
“AN  
INADEQUATE  
SIGN. Not  
visible a few  
feet to either  
side of the  
sairway,”  
photograph,  
1914.

**AN INADEQUATE SIGN. Not visible a few feet to either side of the stairway.**

The New York Association for Improving the Condition of the Poor believed that if comfort stations were hidden or inconspicuous within the built environment, their value and utility would not be recognized by the public. Comfort stations' concealment and obscurity within the built environment was likely residue of the shame that the prior period had attributed to the body's biological functions, and the consequential resistance towards constructing public comfort stations. However, this survey illustrates the emergence of the 20th-century perspective, wherein public comfort stations were deemed imperative public resources and therefore, needed to be prominent so as to encourage both the adoption and appreciation of hygiene practices.

It is important to note *which* public this Association and Bureau anticipated public comfort stations to serve. While suggesting the construction of more comfort stations in general, the survey explicitly stated that “the necessity of such an equipment in the tenement sections is obvious.”<sup>98</sup> The rhetoric underlying this Bureau's discussion of public comfort stations closely resembles those of the first public bathhouses, in which certain populations--namely, Black, immigrant and low-income communities--were believed to need sanitation services more than others, and were therefore perceived as more ‘dirty.’ Not by coincidence, both the first conversations around public bathhouses and public comfort stations were initiated by The New York Association for Improving the Condition of the Poor. During this period, the public bathroom as a project was closely associated with modernism's associations of whiteness with cleanliness, and darkness with ‘backwardness’ or “impending demise.”<sup>99</sup> In this sense, the public bathroom reified racialized and classist hierarchies upon its conception.

In order to ‘teach’ the working and lower class public how to be ‘hygienic,’ as the The New York Association for Improving the Condition of the Poor stated needed to be done,

---

<sup>98</sup> Ibid, 14.

<sup>99</sup> Mabel Wilson, “Black Bodies / White Cities: Le Corbusier in Harlem,” *ANY: Architecture New York* no. 16 (1996): 38.

architects and planners needed to design public comfort stations so as to exemplify the cleansed, sanitary and effective characteristics that they were attempting to teach. Through closer attention to the materiality of public comfort stations' floors and their types of doors, flush attachments, and bathroom fixtures, the upkeep, usage and influence of public comfort stations could be transformed. For example, most of the public comfort stations that were studied had wooden and linoleum floors, both of which were advised to be "discontinued" (Fig 2.3).<sup>100</sup> While changing the materiality of comfort station flooring could have influenced the cleanliness of the space--since lighter materials make dirt, waste or garbage hypervisible--these comments also indicate a desired shift towards modern materialities, criticizing the use of those that had become apparently outdated.

The 1914 survey reported disapproval towards the frequent presence of "antiquated equipment," such as "the old box of closets in which the bowl is enclosed," and which allows "every opportunity for the accumulation of paper and refuse."<sup>101</sup> This critique--as do those on the floors' materialities--draws upon both a desire for 'sanitary' conditions amongst comfort stations, and a desire for modern technologies. New toilet fixtures enabled waste, and toilet paper, to be flushed at a much quicker speed, preventing the accumulation this survey witnessed and delineated. While these new fixtures could have encouraged more sanitary conditions, they also comforted the societal shame and discomfort towards waste, whisking it away in seconds. Moreover, modernist design and public education were to work together. For example, while 'modern' fixtures for distributing paper towels were called for to encourage hand washing, this suggestion was followed up by a recommendation to install instructive placards that signified the importance of their use.<sup>102</sup>

---

<sup>100</sup> *Comfort Stations in New York City: A Social, Sanitary and Economic Survey*, 19.

<sup>101</sup> *Ibid.*, 22.

<sup>102</sup> *Ibid.*, 9.

A clear progression can be traced from the upper-class desire for a more ‘sanitary’ public to the construction and examination of public comfort stations and the urge towards modernism. There had been a clear need for comfort stations in New York City for decades, yet it was beginning to be acknowledged by parties with more authority--controversial parties nonetheless--during this moment of the 20th century. The tool deemed capable of both increasing the number of comfort stations in the City *and* of making them appear more sanitary and modern was standardization, a central component of modernist architecture. This 1914 Survey, therefore, can be seen as a motor that initiated the project of modernization in New York City within the realm of public comfort stations, catching them in a web of modernity.

### **Modernist Architects’ Interventions**

In the early 1900s, modern architects began approaching the bathroom in attempts “to overcome the threat of abjection” that the “germ theory” had enacted in the prior century.<sup>103</sup> In doing so, they realized that bathrooms could also be one part of modern architecture’s process of “purging itself of the ‘false taste’ and ‘scandalous’ love of surface ornamentation that characterized Victorian design.”<sup>104</sup> This period’s discomfort towards waste and distaste towards ornamentation aligned with the purely bare, white and functional design that modern architecture was seeking to popularize, and that other parties had simultaneously begun to desire from public comfort stations. An entirely white and unadorned bathroom was believed to represent “the true spirit of modernism,” perhaps because of its application of new materials, technologies and construction methods, or because of its ability to materialize the current period’s shifting desire towards the minimal.<sup>105</sup> While public bathrooms may not be defined as pieces of modernist

---

<sup>103</sup> Joel Sanders, “Architectural History,” *Stalled!* <https://www.stalled.online/historicalcontext-navigation>.

<sup>104</sup> Penner, *Bathroom*, 84.

<sup>105</sup> *Ibid.*

architecture, they were a site used for exemplifying the qualities that modern architects had begun to envision.

Though most modernist architects were discussing and designing domestic bathrooms, U.S. architect Frank Lloyd Wright undertook the bathroom from a slightly, yet not entirely, public point of view in designing the Larkin Company Administration Building and its bathrooms in 1906. Wright is credited for inventing the suspension of the bathroom partition--today recognized as the stall--within the Larkin Building's bathrooms (Fig 2.3).<sup>106</sup> This decision was meant to promote ease of cleaning. Typical bathroom partitions at the time were attached to the floor, creating several enclosed spaces that could only be cleaned by fully opening their doors and entering. Alternatively, the gap between the partition and the floor that Wright's design created allowed for much quicker mopping, while also minimizing the time cleaners had to spend near the toilets.<sup>107</sup> Within his suspension of the stall, Wright was responding to modernity's desires for efficient time management and visual distance from waste.

---

<sup>106</sup> Beatriz Columbia and Mark Wigley, "Toilet Architecture: An Essay About the Most Psychosexually Charged Room in a Building," *PIN-UP* no. 23 (2017/2018), <https://pinupmagazine.org/articles/toilet-modern-architecture#16>.

<sup>107</sup> Frank Lloyd Wright, *An American Architecture* ed. Edgar Kaufmann (New York: Bramhall House, 1955).



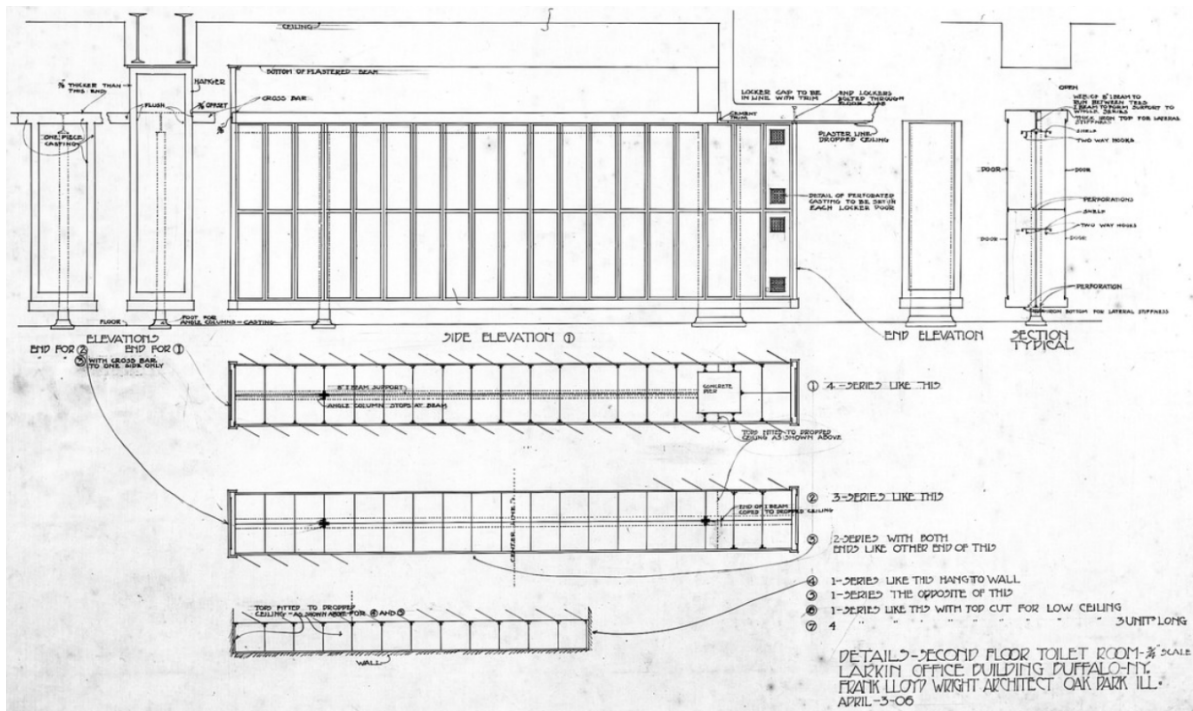

Figure 2.3: Frank Lloyd Wright, Elevation of Larkin Building's 2nd Floor Toilet Room, 1906.

The pursuit of a 'truly modern' bathroom led to an aesthetic that both responded to and drew from the process of industrialization. Industrialization had enabled the mass-production of materials that were non-porous, enameled or glazed and therefore easy and quick to clean--such as marble, glazed tiles or chrome-plated metal, which were also, non-coincidentally, light-colored materials. The associations between light-colors, cleanliness and improved health were already centuries old at this time. Neolithic constructions found in southeast Asia from around 10,000 years ago have been excavated and illuminated the first synthetic material that was ever created by humans, as a response to their health suffering from unfamiliar pathogens--a white lime plaster that was capable of disinfecting the surfaces of interiors and creating a "continuous sealed skin" between the floors, walls, and ceilings.<sup>108</sup> Multiple layers of this lime

<sup>108</sup> Mark Wigley, "Chronic Whiteness," *Sick Architecture*, e-flux Architecture (November 2020) <https://www.e-flux.com/architecture/sick-architecture/360099/chronic-whiteness/>.



plaster were applied until reaching the smoothest and “whitest” layer, which would continue to be “regularly redone to preserve the effect.”<sup>109</sup>

This cycle of declining health leading to the production, application and reapplication of white lime plaster was later transferred over to limewash, becoming the material applied to the walls of the first privies and public urinals during the 19th century and throughout the subsequent cholera and typhoid outbreaks.<sup>110</sup> Towards the end of the 19th century, a brand of “impermeable and washable enamel ‘sanitary paint’” was invented, promoted both for its antibacterial purposes and for its ability to spotlight the presence of “dirt or darkness.”<sup>111</sup> Throughout the 20th century, architects used, applied and reapplied such materials to endow their buildings with an ‘imagery of hygiene,’ both amongst the space and those within.<sup>112</sup> Light-colored materials--later encapsulated by the concept of ‘whiteness’--have historically been perceived as an instrument for improving health conditions. Further, the process of application and reapplication that such materials have historically been subjected to represents how whiteness “is not a fixed thing but the idea of a fixed thing” that must be upheld through continuous, committed repetition; the characterization of ‘whiteness’ as a ‘clean slate’ or as ‘pure’ is firmly dependent upon the time and labor of others, and could not exist otherwise.<sup>113</sup>

Architects’ belief that constructing spaces devoid of color and ornament would improve a society’s cleanliness, and consequently morality, was supported by their idea that ‘whitewashing’ could be used as a “technology of surveillance that would put in motion an ever-expanding culture of self-policing.”<sup>114</sup> Surrounding people with spaces and materials that were bare and minimal, and maintained so as to consistently remain this way, was believed to

---

<sup>109</sup> Ibid.

<sup>110</sup> Penner, *Bathroom*, 119.

<sup>111</sup> Wigley, “Chronic Whiteness.”

<sup>112</sup> Penner, 119.

<sup>113</sup> Wigley, “Chronic Whiteness.”

<sup>114</sup> Le Corbusier, *The Decorative Art of Today* (Cambridge: MIT Press, 1987), 188.

inspire gravitation towards an “inner cleanliness” that saw one’s physical and mental conditions as intertwined.<sup>115</sup> The connections drawn between architectural designs and physical and mental health rested upon the characterization of the process of whitening as purifying.<sup>116</sup> By ‘whitening’ the built environment, architects made declarations about what did or did not ‘pass’ as clean and, by default, ‘moral.’ While ‘whitewashing’ had been a response to illness for thousands of years, industrialization and architectural movements of the 20th century enabled the scale and approach of this process to substantially expand.

Standardization had been transforming architectural production and architectural movements throughout the beginning of the 20th century. The Deutscher Werkbund, founded in Germany in 1907 by Hermann Muthesius, saw standardization as necessary to composing and uplifting a nation and more broadly, a national identity in the age of industrialization.<sup>117</sup> Both leading up to and following the founding of the Werkbund were debates surrounding the balance between craftsmanship and industry, particularly regarding which could more significantly improve the country’s quality of life.<sup>118</sup> Architects, engineers and administrators began considering the application of industrialized standards within various contexts, eventually reaching the public bathroom. As the 20th century unfolded, bathroom fixtures became more and more engulfed by “an anonymous industrial process,” fixed by standards and catalogs.<sup>119</sup> Sanitaryware manufacturers were responsible for both the design and production of bathroom fixtures, streamlining and standardizing both their aesthetic and functions.<sup>120</sup> Beyond just the fixtures placed within and their corresponding functions, bathrooms’ dimensions had also

---

<sup>115</sup> Wigley, “Chronic Whiteness.”

<sup>116</sup> Ibid.

<sup>117</sup> “Deutscher Werkbund,” *A Dictionary of Modern Architecture: University of Chicago*, November 16, 2015, <https://voices.uchicago.edu/201504arth15709-01a2/2015/11/16/deutscher-werkbund/>.

<sup>118</sup> “Deutscher Werkbund (1907-1933),” *Visual Arts Cork*, <http://www.visual-arts-cork.com/architecture/deutscher-werkbund.htm>.

<sup>119</sup> Penner, *Bathroom*, 123.

<sup>120</sup> Ibid.

become products of formulaic and ‘universal’ standards. Standardization, industrialization and modernity all shared similar intentions--making production and construction processes much faster, cheaper, more efficient and more consistent.

During this same period, “a new sort of architectural book appeared,” in which diagrams, dimensions and standards were delineated into handbooks that were circulated throughout architecture schools.<sup>121</sup> The initiation of this form of architectural book represented a new approach to architecture, which presumed that “the standardization of building elements could be predicated upon the...routinization of the human activities that they accommodated.”<sup>122</sup> By assuming predictable regularities within human activity, the standardization of building types could appear more in sync with those that would use them. In order to standardize human activity, architects had to standardize the human being.

Among the figures to launch such handbooks was German architect Ernst Neufert. His internationally acclaimed handbook, *Architects' Data*, was first published in 1936 and has been revised into 39 editions since, becoming a classic handbook for architects and architecture students across the world. There are several sections of the handbook--spanning over 300 pages with various architectural drawings throughout--starting with drawing practice, moving to delineating the human scale, culminating with a variety of references and dimensions for different architectural spaces, including bathrooms.

This handbook revolves around a “universal standard” of “the human scale,” a result of Neufert’s ‘theory of planning’ which proposed a framework for determining the dimensions of buildings and their constituent parts based on the human body.<sup>123</sup> While he believed that architects needed to stop basing their designs on “arbitrary scales instead of on the only correct

---

<sup>121</sup> Emmons and Mihalache, “Architectural handbooks and the user experience,” 36.

<sup>122</sup> Ibid.

<sup>123</sup> Ernst Neufert, *Architects' Data* ed. Rudolf Herz, trans. G.H. Berger, et al., (Hamden: Archon Books, 1970), 13.

scale--man himself,” the ‘man’ that became Neufert’s reference was composed using “relative proportions” and therefore, inherently, was not a universally ‘correct’ scale but a biased and subjective one (Fig 2.4).<sup>124</sup> Therefore, while *Architects’ Data* was meant to guide architects through an intentional design process, it encouraged an application of dimensions and proportions that, unavoidably, would exclude certain bodies.

---

<sup>124</sup> Ibid.

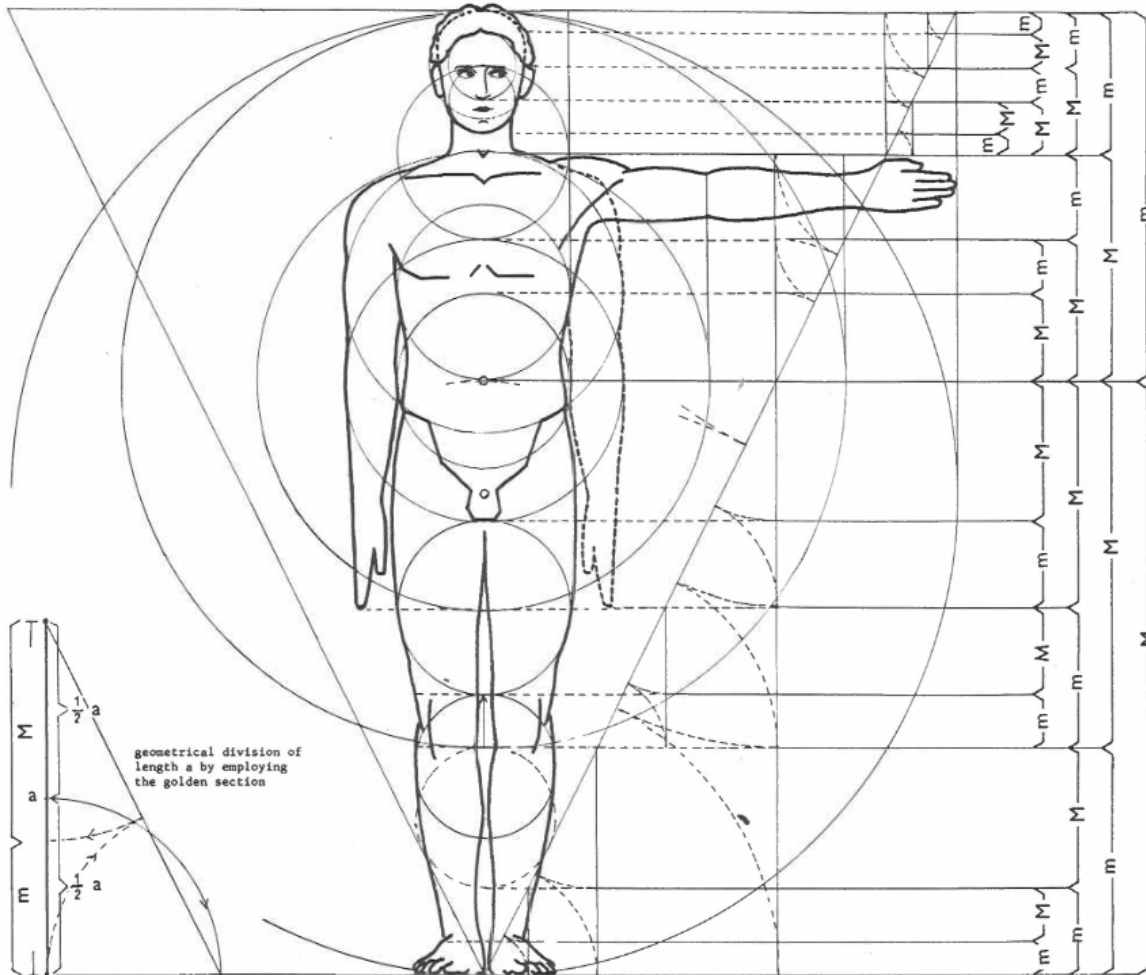

#### Relative proportions of man

The oldest known standard of human proportions (c. 3 000 B.C.) was discovered in one of the tomb-chambers in the pyramids of Memphis, so from that time onwards, and perhaps earlier, scientists and artists have been concerned with the study of human proportions. We know of the standards of the empire of the Pharaohs, of the Ptolomaic period, of the Greeks and Romans, and of Polyklet (all of which were accepted as norms for a considerable time); of the teachings of Alberti, Leonardo da Vinci, Michelangelo and others, the work of Dürer being particularly important.

In these systems the human body is measured by the length of the head, face or foot – at a later date they were subdivided and related to each other so that they became standardized in everyday use. In modern times, feet and ells (yards) are accepted measurement.

Dürer's findings met with general agreement. He began with the whole body-height and then determined subdivisions as follows:

- $1/2 h$  = upper half of body from groin;
- $1/4 h$  = length of leg from ankle to knee, and distance from chin to navel;
- $1/6 h$  = length of foot;
- $1/8 h$  = length from crown of head to chin, and distance between nipples;
- $1/10 h$  = height and width of face (including ears), length of hand to wrist;
- $1/12 h$  = width of face at lower end of nose.

These subdivisions are taken to  $1/40 h$ .

During the last century Zeising in particular has helped to clarify the basis of the 'golden section' through his research into the comparative dimensions of man, but his work did not get adequate appreciation until supported by Moessel after intensive examination. Corbusier used the golden section as 'Le Modulor' for all his projects after 1945, his measurements being: height of man = 1.829 m, height to navel = 1.130 m, etc. → p. 25.

Figure 2.4: Ernst Neufert, "Universal Standard" and "Relative proportions" of man, *Architects' Data*.

Echoing the visions of other modern architects, Neufert stated that an attunement to ‘the human scale’ would ensure efficient movement and labor “without space being wasted.”<sup>125</sup> In the subsection on “Bathrooms,” Neufert included drawings of various bathroom appliances, either showing the ‘universal’ man utilizing them or implicitly shaping their design around his proportions (Fig. 2.5).<sup>126</sup> While his drawings ensured the efficient use of space and movement for this ‘universal man,’ his standardization of human proportions automatically prohibited spaces from cultivating any collective efficiency or cohesiveness, as this universal subject catered to the realities of some people and neglected others. Neufert’s view of the user as a “standardized ‘subject’ inhibits the architects’ engagement with the unique attributes” of individuals’ needs, movements and realities.<sup>127</sup> Instead, this uniqueness was flattened through such handbooks, presuming that architecture’s functionality was a “choreography between the body of the user and the building,” that could be anticipated, coordinated and repeated.

---

<sup>125</sup> Neufert, *Architects’ Data*, 13.

<sup>126</sup> *Ibid.*, 132.

<sup>127</sup> Emmons and Mihalache, “Architectural handbooks and the user experience,” 44.

## BATHROOMS

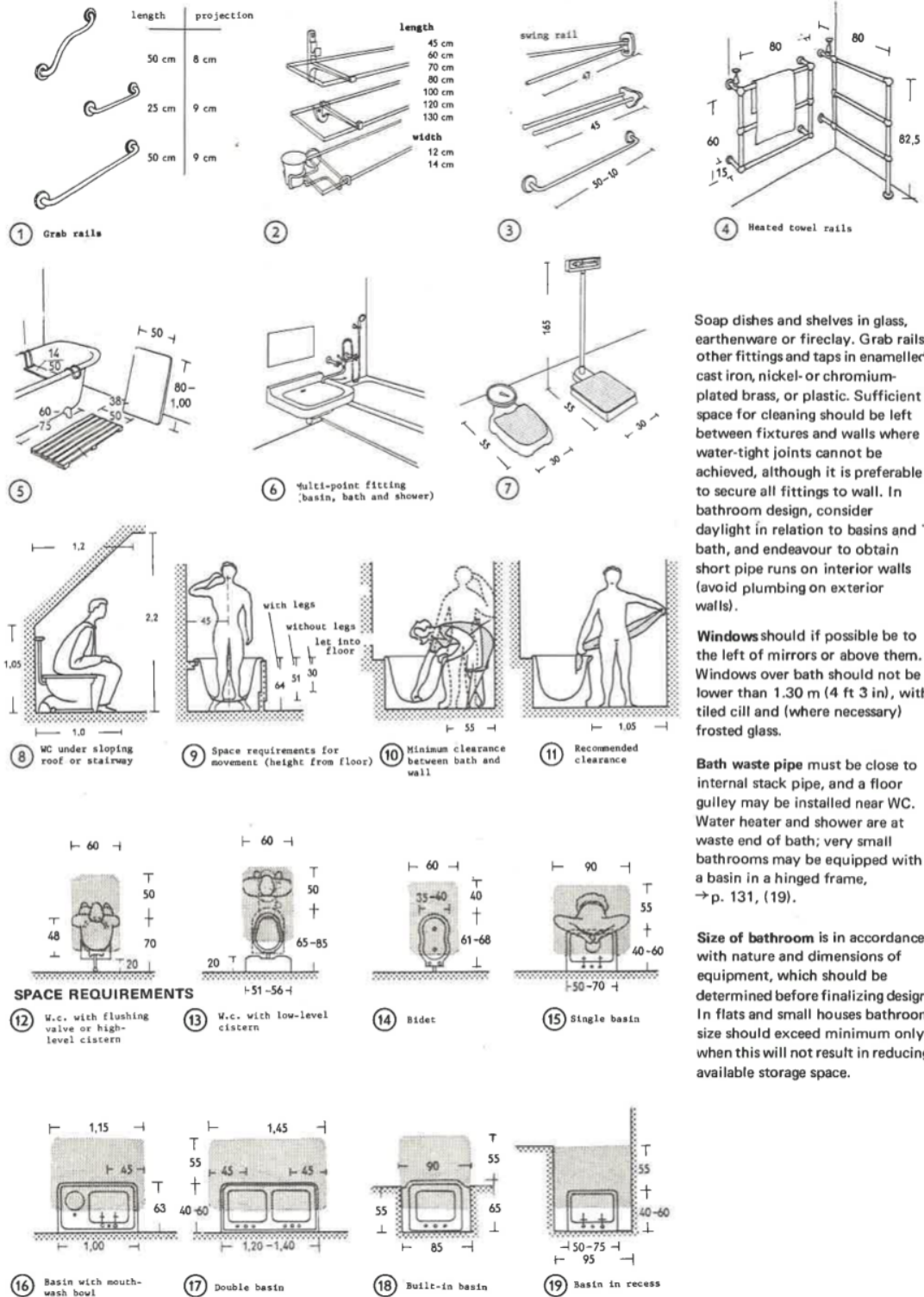

Soap dishes and shelves in glass, earthenware or fireclay. Grab rails, other fittings and taps in enamelled cast iron, nickel- or chromium-plated brass, or plastic. Sufficient space for cleaning should be left between fixtures and walls where water-tight joints cannot be achieved, although it is preferable to secure all fittings to wall. In bathroom design, consider daylight in relation to basins and bath, and endeavour to obtain short pipe runs on interior walls (avoid plumbing on exterior walls).

Windows should if possible be to the left of mirrors or above them. Windows over bath should not be lower than 1.30 m (4 ft 3 in), with tiled cill and (where necessary) frosted glass.

Bath waste pipe must be close to internal stack pipe, and a floor gully may be installed near WC. Water heater and shower are at waste end of bath; very small bathrooms may be equipped with a basin in a hinged frame, → p. 131, (19).

Size of bathroom is in accordance with nature and dimensions of equipment, which should be determined before finalizing design. In flats and small houses bathroom size should exceed minimum only when this will not result in reducing available storage space.

Figure 2.5: Ernst Neufert, "Bathrooms," *Architects' Data*.

None of the drawings within this section depict stalls or any other features that imply consideration for public bathroom design--while this is emblematic of architects' disinterest in participating in the design of public bathrooms, it also illuminates how the consequences of designing around a standardized subject were not considered. Applying standardized dimensions to public spaces--especially public bathrooms, in which use is entirely depending upon one's body being compatible with the dimensions and fixtures--asserts who the public is, or is not, structured around. Therefore, as architects turned to Neufert's handbook out of a desire for consistency and precision, they did so at the risk of creating exclusive or hostile spaces. While the architects who designed the first standardized public comfort stations may not have used *Architects' Data*, this handbook was one of several modernist handbooks that combined "classic concepts of universality and modern notions of standardization to solidify the architects' role as design authority."<sup>128</sup> Therefore, if not drawn directly from Neufert, public bathrooms built during this period of the 20th-century were likely products of similar 'universal' proportional and dimensional standards.

### **Documenting Standardization**

Around 15 years after The New York Association for Improving the Condition of the Poor's 1914 survey, New York City Mayor Fiorello La Guardia unified the city's five, distinct borough parks systems into one, under the management of a citywide Parks Commissioner, Robert Moses.<sup>129</sup> Mayor La Guardia appointed Moses to this position with the instruction to

---

<sup>128</sup> Aimi Hamraie, *Building Access: Universal Design and the Politics of Disability* (Minneapolis: University of Minnesota Press, 2017), 26.

<sup>129</sup> Rebekah Burgess and Mariana Mogilevich, "Cataloging Comfort," *Urban Omnibus*, May 2, 2018, <https://urbanomnibus.net/2018/05/cataloging-comfort/#:~:text=In%20the%201930s%2C%20when%20Robert.access%20to%20the%20public%20realm.>



better the city's atmosphere "through urban renewal."<sup>130</sup> One of the first of Moses's various, controversial projects following such guidance was the coordination of a crew of photographers to document the public works to come under his leadership. One album, dated from 1934, surveyed the conditions of the city's parks' comfort stations, with corresponding descriptions and instructions to guide their upcoming renovations, characterized as a window into "a moment of modernization in modesty."<sup>131</sup>

Building off of the 1914 Survey from twenty years prior, the photographic 1934 Survey illustrates the role that public comfort stations played in New York City's gradual gravitation towards modernity and modern design. More broadly, this survey also exemplifies how Robert Moses situated the public comfort station within his initiation of urban renewal processes. The presence of public comfort stations within such processes of 'renewal' is reminiscent of the work done by New York City government officials and upper-class administrators from the 19th century, in which the 'cleansing' of non-white, non-rich communities through the construction of public bathhouses was considered necessary for the 'renewal' and reinvigoration of the city. There has historically been an association drawn between the conditions of New York City's sanitary services and its overall status.

Throughout this photographic report, the absence or presence of 'modern' design is noted on almost every page, exemplifying how Moses's team, and the New York City government more generally, guided their reconstruction projects through inclinations and impulses for modernity. The typed notes that accompany each image report the need for some comfort stations, such as those at Prospect or Central Park, to be "demolished and replaced by a modern structure" by including "the following fixtures: in the men's area 6 urinals, 5 water closets and 2

---

<sup>130</sup> Paul Goldberger, "Robert Moses, Master Builder, is Dead at 92," *The New York Times*, July 30, 1981.

<sup>131</sup> Burgess and Mogilevich, "Cataloging Comfort."

lavatories; in the women's area, 4 water closets, 2 baby water closets and 2 lavatories” (Fig. 2.6, Fig 2.7).

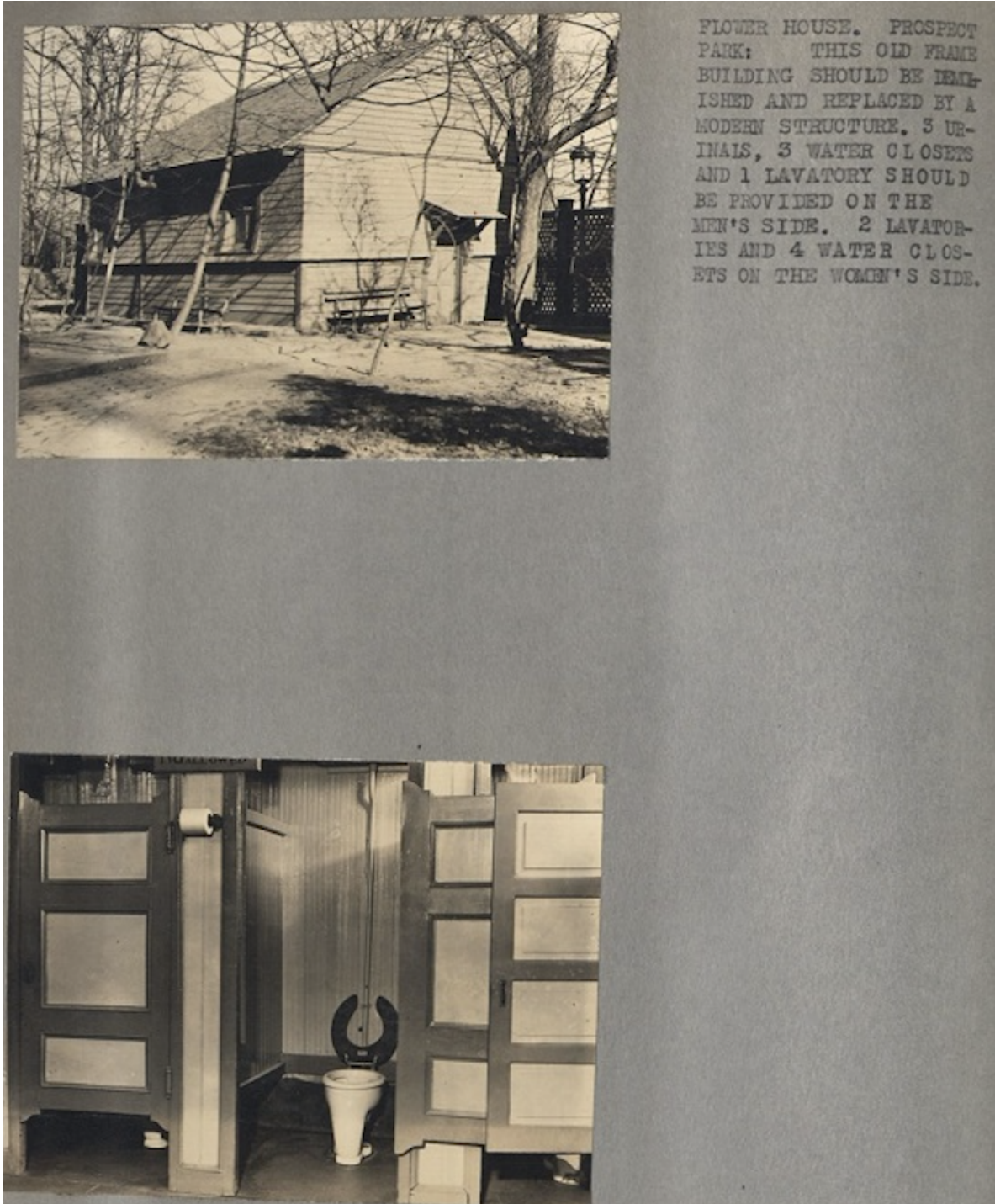

Figure 2.6: Department of Parks NYC, Prospect Park Comfort Station, *Comfort Stations Survey of 1934*.

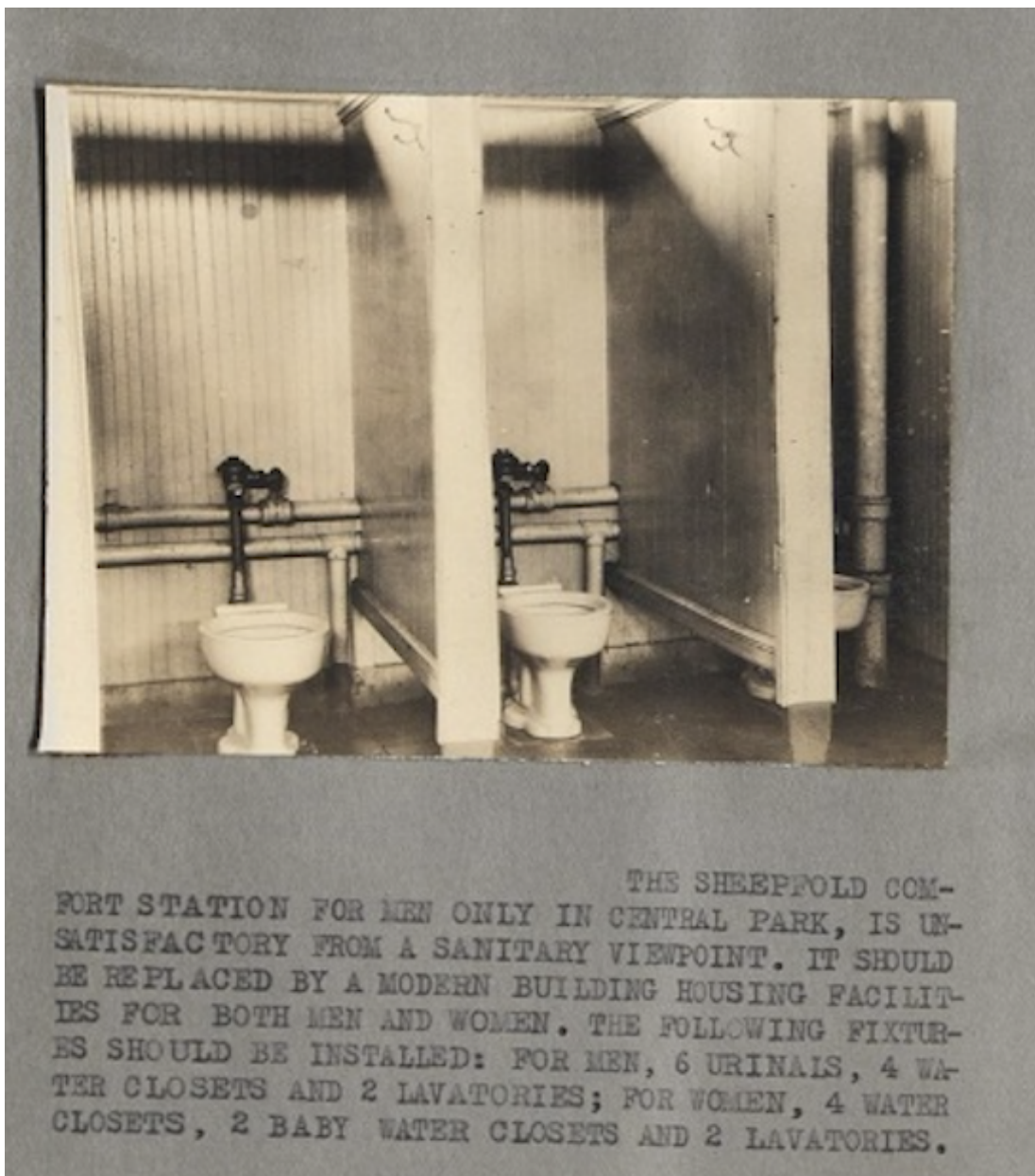

Figure 2.7: Department of Parks NYC, Central Park Comfort Station, *Comfort Stations Survey of 1934*.

Other comfort stations, such as those at Union Square, are marked “well planned and equipped,” with an extra comment, “note: modern fixtures” (Fig 2.8, Fig. 2.9, Fig. 2.10). Evidently, the word “modern” held particular value and significance during this period, employed either to signal the dire need for renovation or the discovery of a potential precedent. In many cases, the comments of the 1934 Survey mirror certain complaints from the 1914 Survey, indicating how desires for modern materialities and fixtures were becoming more

widespread across New York City. The images included of the Union Square comfort station are resemblant of traditional 21st-century public bathroom design--through their tiled walls, lines of metal stalls and general use of light-colored materials--exemplifying how the comfort stations deemed satisfactory by Moses's team likely became precedents to guide later constructions.





UN-  
ION SQUARE: THIS UNDER-  
GROUND COMFORT STATION IS  
WELL PLANNED AND EQUIPPED.  
NOTE: MODERN FIXTURES.



Figure 2.8: Department of Parks NYC, Union Square Comfort Station, *Comfort Station Survey of 1934*.



Figure 2.9: Department of Parks NYC, Union Square Comfort Station, photograph from *Comfort Station Survey of 1934*.



Figure 2.10: Department of Parks NYC, Union Square Comfort Station, photograph from *Comfort Station Survey of 1934*.

Following the completion of this photographic survey, Robert Moses and his team created 9 different types--from Type A to Type N--for New York City's public parks' comfort stations. While these types were specifically meant for the comfort stations within the city's public parks, this archival material can provide insight into how planners and architects envisioned public bathroom design more broadly during the 20th century. There are clear differences between some of the types, suggesting experimentations that were potentially shut down or phased out after being proposed either due to greater construction prices or feared ineffectiveness. Simultaneously, there are distinct similarities among many types, potentially indicating which features were generally approved of or deemed wise. Certain elements within these types can still be found in public bathrooms today, supporting the possibility that these types may have been circulated and repeated elsewhere in New York City. This speaks to the solidifying and reinforcing nature of architectural standardization--once constructed, the components of a standard can not easily be revised or discarded, as they are all needed for upholding the entirety of the structure.

To explore the various approaches that Moses's team took when attempting to modernize the public comfort station, I will focus on two types--Type C and Type N. These two types demonstrate two different, yet also similar, approaches to designing public comfort stations equipped for modernity. Type C was dated from 1937 and Type N from 1941, therefore isolating these two types is also helpful for tracing the evolution of NYC Parks Department's approach to the modernization of the public comfort station, since this is the largest time difference--being five years--between the nine types. Through these two types, the comfort station's embodiment of modern architecture's qualities and principles can be identified, further strengthening the interrelation between modernity and hygiene.

Entering Type C's public comfort station would first require locating either the men's or women's entrance, placed on opposite sides of the structure--therefore, neither male, female or anyone identifying in between being forced to make a choice, would be in view of the other (Fig 2.11). Upon entering, one is met with a vestibule area, prior to the entryway into the bathroom space. The site plan is in the shape of an octagon, reminiscent of the site plans for the first public bathhouses, which were structured by a desire for surveillance and social control (Fig 2.12). Type C's site plan enforced a similar sense of visibility and controlled movement via the pathways of circulation that its structure motivated.

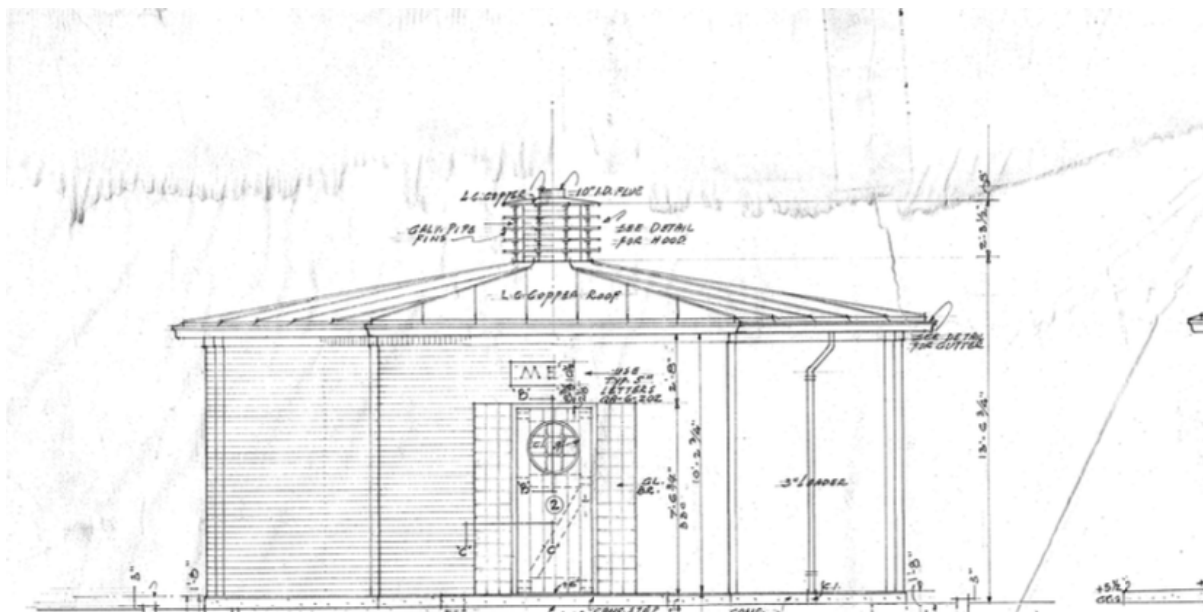

Figure 2.11: Department of Parks NYC, Type C, men's door side elevation, 1937.



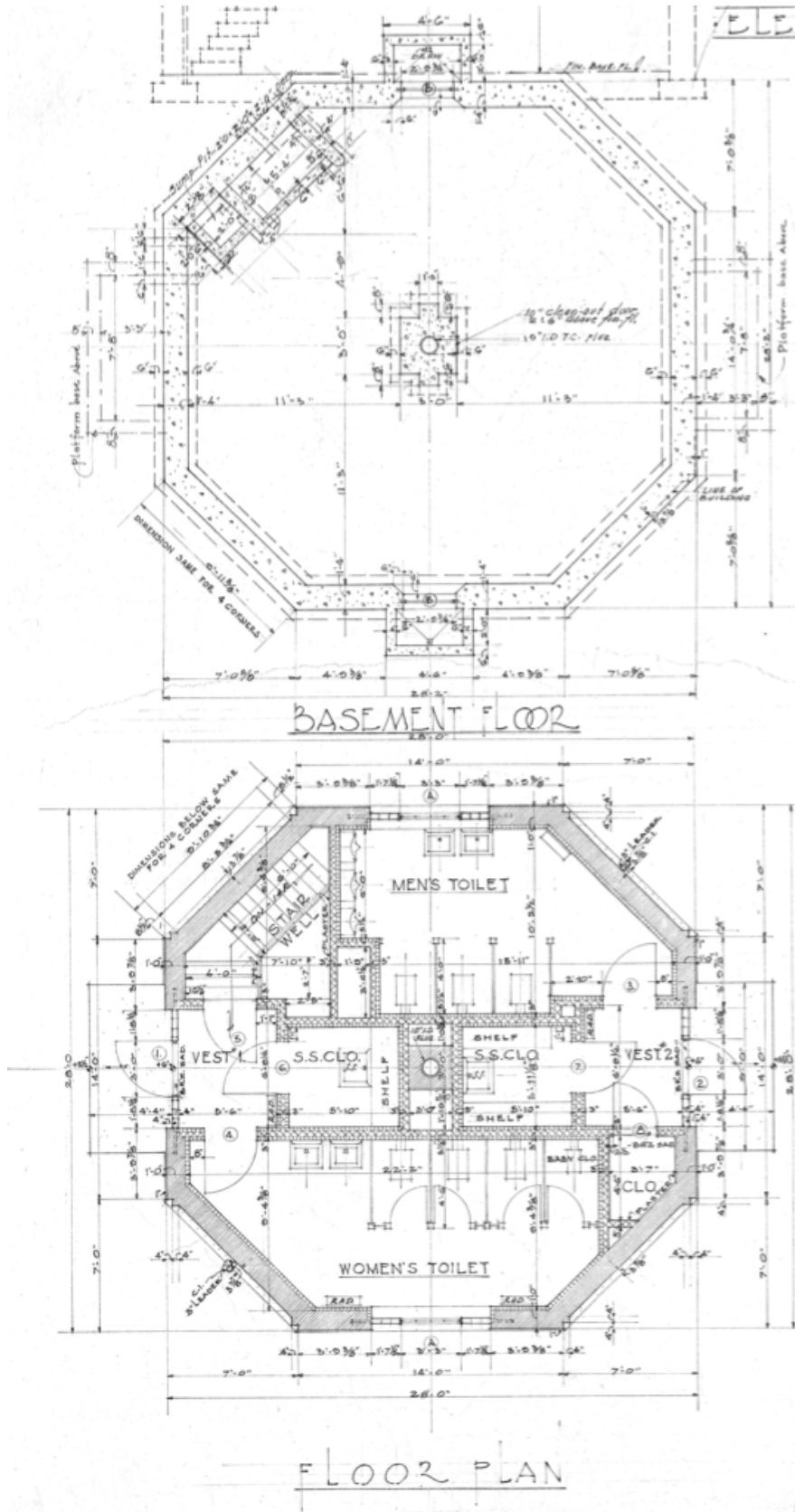

Figure 2.12: Department of Parks NYC, Type C, basement floor and ground floor plans, 1937.

Similarly, to enter Type N's public comfort station, you must first locate your 'respective' side--the men's' and women's entrances were placed on either side of the structure, again keeping each party's entrance and exit invisible to the other (Fig 2.13). Though not immediately apparent or sensed within, the men's and women's spaces were side-by-side, as opposed to facing one another, a shift enabled by Type N's rectangular site plan (Fig 2.14). The men's and women's sections lacked the vestibule-like area found in Type C, therefore one would find themselves directly in the bathroom space upon entering. While the rectangular shape of Type N's plan revoked the surveilling capabilities of Type C's octagonal site plan, structural choices were implemented to maintain a sense of visibility within the public comfort station. Though not substantially detailed, Type N's plans indicated that the stalled toilets were to be placed perpendicular to the comfort stations' entrances while also being parallel to the sinks--therefore, those entering the comfort station would see those exiting the stalls and those at the sinks, and those exiting the stalls would see those entering and at the sinks (Fig. 2.15).

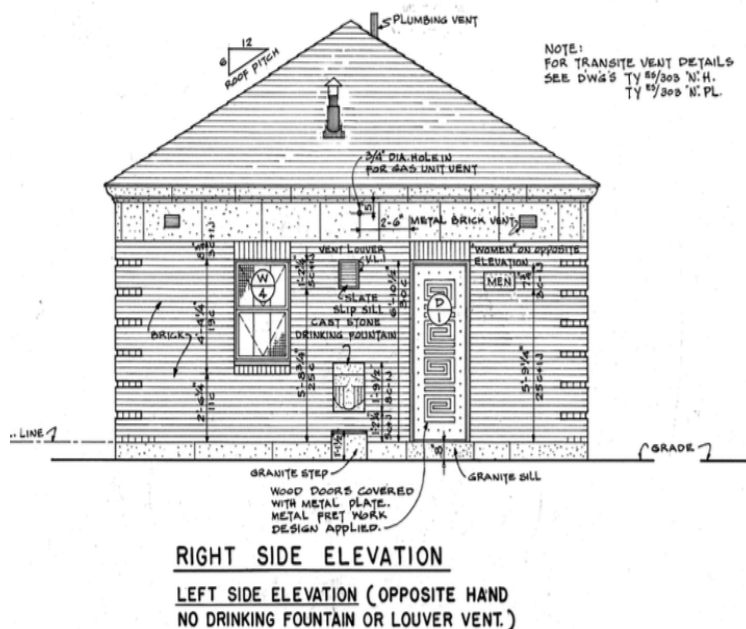

Figure 2.13: Department of Parks NYC, Type N, front and right side elevations, 1941.

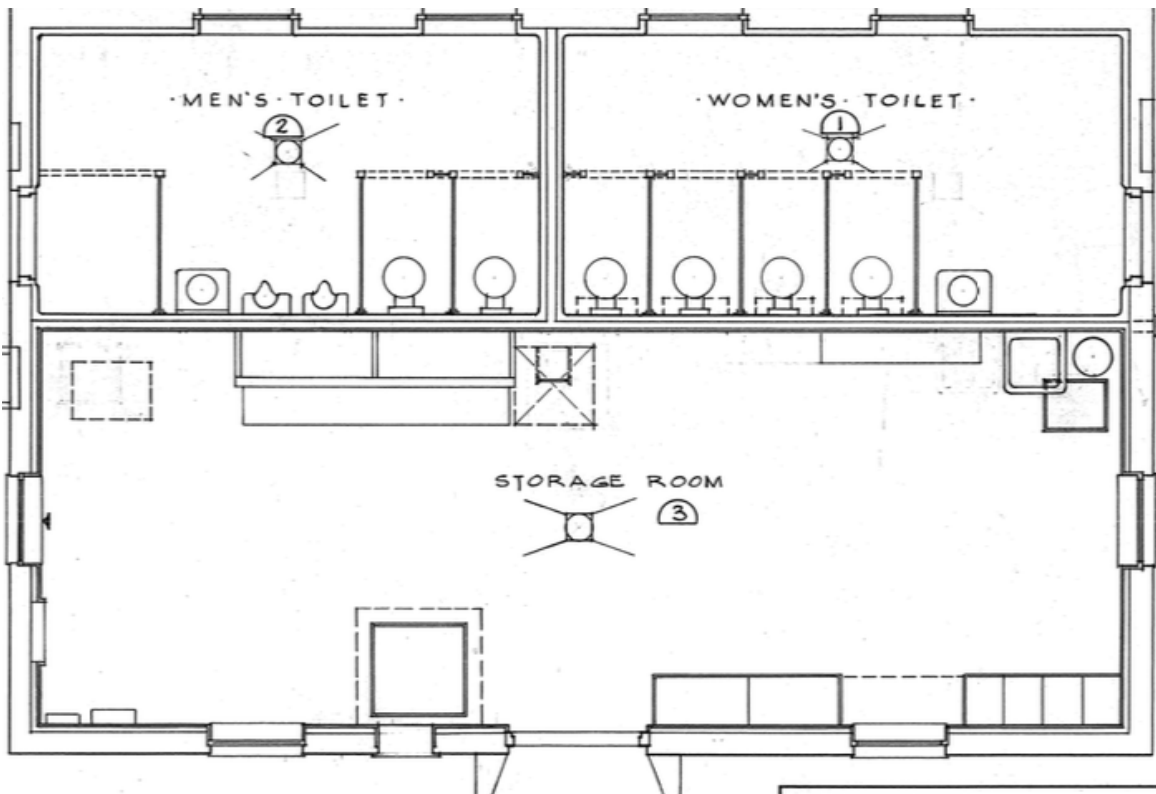

Figure 2.14: Department of Parks NYC, Type N, floor plan "scheme 2," 1941.

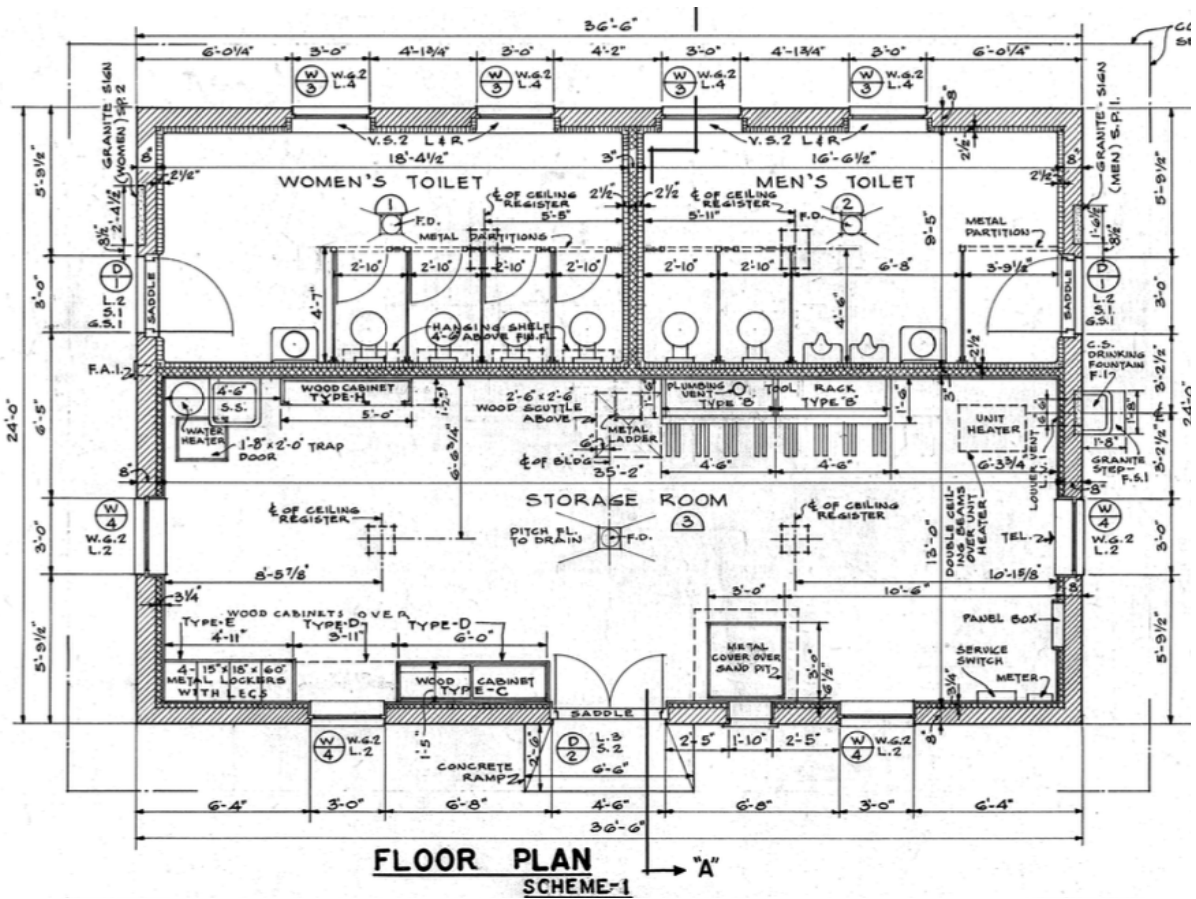

Figure 2.15: Department of Parks NYC, Type N, floor plan "scheme 1," 1941.

The paradoxical dichotomy between exposure and concealment is illustrated throughout the nine types. While floor drains were installed, toilet flushes were quickened and plumbing fixtures became more discreetly placed, as responses to the critiques from both the 1914 and 1934 comfort stations surveys--and, more widely as a response to the societal fear and disgust towards waste, hence taking measures to 'hide' it--the reliance on plans that motivated visibility and observance made prominent the arguably most vulnerable component of the bathroom, the source of the waste (the people within).

The restructuring of the public comfort station, both internally and externally, between Type C and Type N depicts a completely alternative usage of the space. This shift could have been done to simplify plumbing networks, or to intentionally motivate an alternative path of circulation. Type N's quickening of the entry into the public comfort station--and its simplification of the shape of the plan--may have also been a response to modern architects' understanding of modern life as quick and efficient, stressing the value of time, both in construction and in use. The desire for modernity was strung throughout the NYC Parks photographic survey, therefore it was likely a key consideration when developing these various types. This emphasis on modern design can also be found in the evolution of roofing style and materiality between Type C and Type N. Whereas Type C's roof is octagonal and copper, Type N depicts a pitched, slate roof, a typical roofing style in modern buildings (Fig 2.16, Fig. 2.17). Similar modern inspirations could be said of the consistency of the materialities noted throughout every type, all of which were industrial, light-colored and easy to clean: glazed quarry tile, cement, glass, plaster.

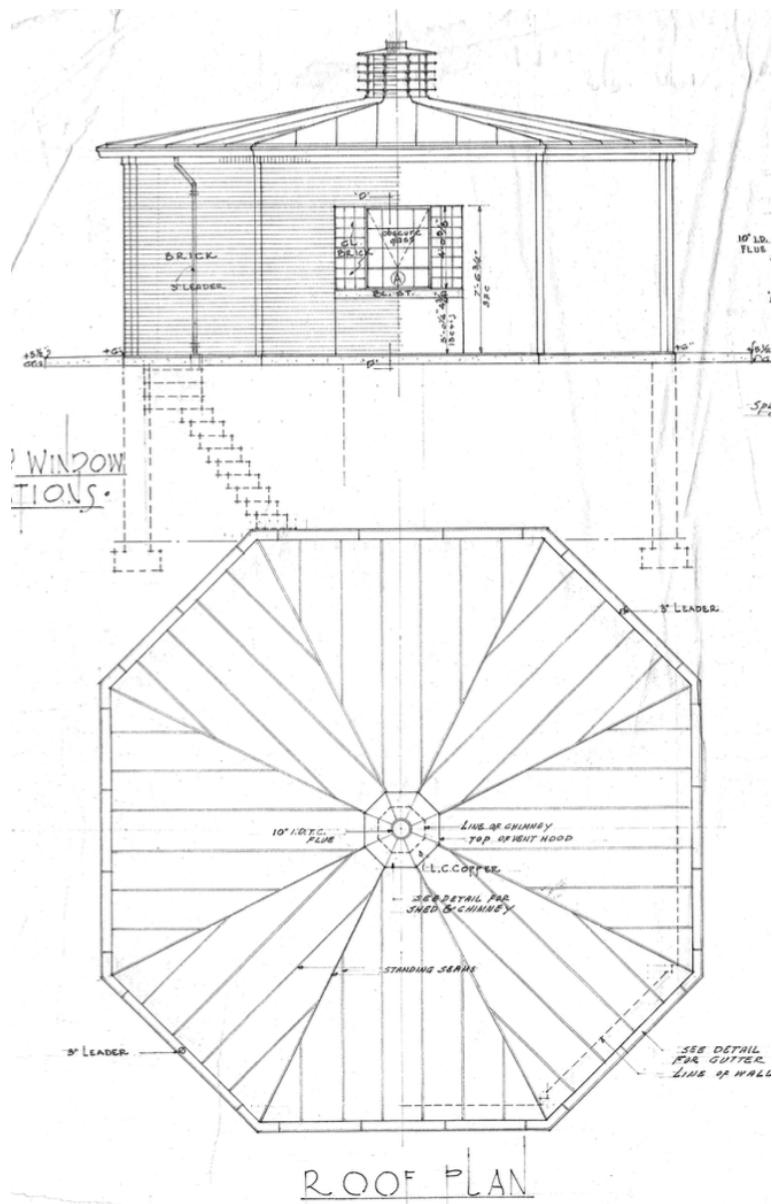

Figure 2.16:  
Department of Parks  
NYC, Type C, roof  
plan, 1937.

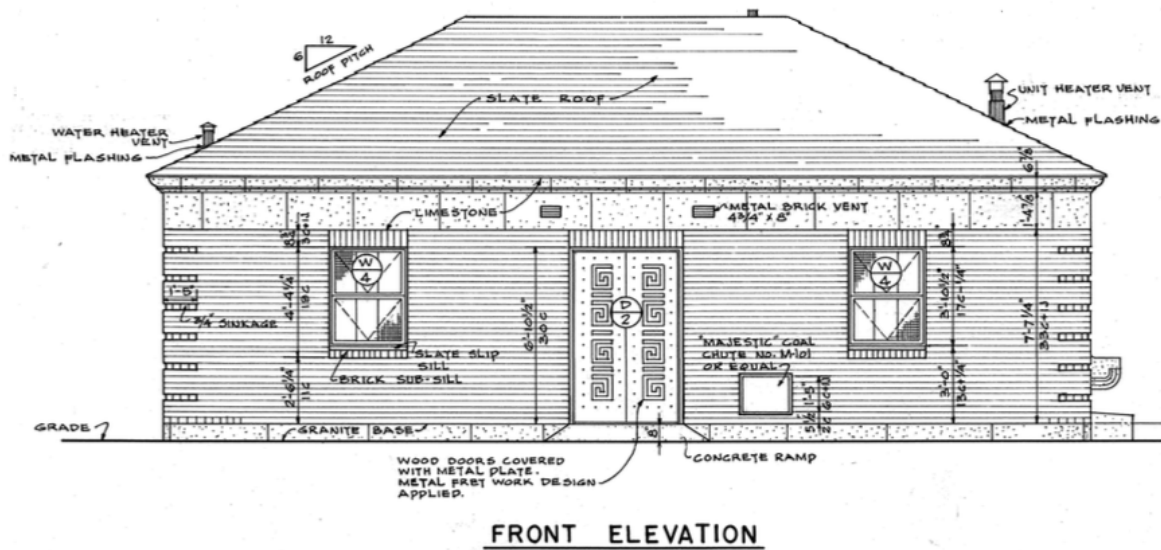

Figure 2.17: Department of Parks NYC, Type N, front elevation, 1941.

Critiques and disapproval of certain ‘antiquated’ materials are scattered throughout the Department of Parks 1934 photographic report. In some cases, the call for the demolition or complete renovation of certain public comfort stations rested upon their materialities--“the walls are brick, the ceiling open rafter ones, partitions, wood.” (Fig. 2.18). In other cases, certain public comfort stations were “well-equipped in every respect except stalls,” in which it is recommended that their wooden doors be replaced with “modern metal stalls” (Fig 2.19). Evidently, serious attention was paid to public comfort stations’ materiality, likely due to the similarly significant role of materiality within modern architectural discourse at the time. The materials listed throughout the nine types mirrored the beliefs of modern architects in that bathrooms should be composed of light-colored and easy to clean materials. The overlap between the materials that were becoming industrialized and mass-produced and those that were characterized as ‘modern’ materials is made clear once again. Further, ‘modern’ sanitary fixtures of “porcelain or enameled iron, from reliable makers” was also believed to signal “American superiority around the globe--one that could be peddled to ‘older countries’ who lagged ‘far behind’ plumbing achievements.”<sup>132</sup> The materiality of sanitation, evidently, was saturated with symbols and implications.

---

<sup>132</sup> Davis, *Bathroom Battlegrounds*, 74.

5



RED HOOK PARK: THIS COMFORT STATION SHOULD BE EITHER REHABILITATED OR DEMOLISHED ACCORDING TO THE DESIGN DIVISION'S DECISION. THE WALLS ARE BRICK, THE CEILING OPEN RAFTER ONES, PARTITIONS, WOOD, AND FIXTURES OF AN ANTIQUATED TYPE.



Figure 2.18: Department of Parks NYC, Red Hook Park Comfort Station, *Comfort Stations Survey of 1934*.



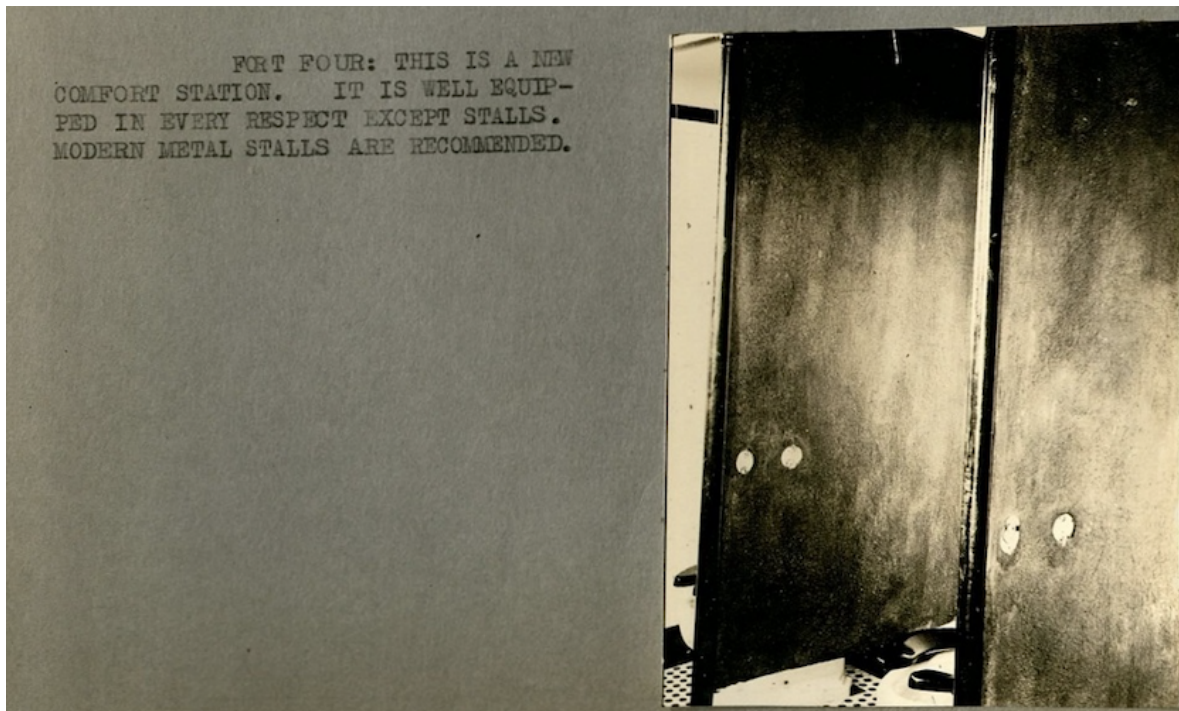

Figure 2.19: Department of Parks NYC, Fort Four Comfort Station, *Comfort Stations Survey of 1934*.

From their site plan, materialities, and stall dimensions, to the photographic survey's recurring call for 6 urinals, 6 water closets and 2 lavatories for the men's section and 6 water closets, 2 baby water closets and 2 lavatories for the women's, these archival documents illustrate how the public comfort station began to fall into a standardized mold. The photographs within this report are also evidence of the inconsistencies and disorder that the 1914 Survey was taking note of. Each component of the public bathroom's standardization process was a product of industrialization and modern architectural design principles, while also continuing to respond to the prolonged societal discomfort towards abjection and the bodies of others. While architectural standards served to transform buildings into rigid and consistent types, it also, in the process, generalized and homogenized the people that would enter them, hoping, too, for consistent and predictable usage.



## Accessing Standards

Robert Moses's attention to parks' public comfort stations may be seen as a reconsideration of access to public space. Moses's attunement to access, however, must be foregrounded by his perception of 'public.' For example, in locating sites for public park development, Moses led "clearance projects" in which housing units populated by low-income Black and Hispanic communities were destroyed to make room for public spaces that, in turn, displaced them.<sup>133</sup> Further, Moses's criteria for park development was "neighborhood-specific"; he ensured that the sites he selected maintained racial segregation through their intentional placements either in proximity to, or distanced from, communities of color.<sup>134</sup> The use of 'public' within the public comfort stations redeveloped under Robert Moses was exclusionary, prejudiced and intolerant. It is notable that access to sanitary services is either directly targeted at marginalized communities, or intentionally withheld from them--during the 20th century, the public bathroom continued to be a symbol of sociocultural ideals as well as a method for enforcing them.

From certain, narrow perspectives, access into the public realm was widened through the standardization of public comfort stations. The enlargement of women's public comfort stations alongside the implementation of fixtures for babies represented the acceptance of (white, middle- and upper-class) women and mothers participating in the city's public. Concurrently, the discrepancies between the numbers of fixtures within the women's and men's sections, with men having substantially more fixtures, can be questioned--were there any grounds for these variations, or was it intentionally planned that women would have to form and wait in lines that

---

<sup>133</sup> Joel Schwartz, "Robert Moses and City Planning," *Robert Moses and the Modern City* ed. Hilary Ballon and Kenneth T. Jackson (New York: W.W Norton & Company, 2007): 130-133.

<sup>134</sup> *Ibid.*

men would never encounter? Moreover, white women and white mothers were the demographic being encouraged and welcomed into public spaces and parks during this point of the 20th century. Black women and other women and mothers of color were never confined to the domestic sphere as white upper-class women had been; instead, they were constantly exploited members of the working class, who were not granted the same privileges to recreational or personal time in public spaces. While governmental attention to improving public resources--such as comfort stations--is often characterized positively, whom these resources were likely intended for, and consequently who would be made to feel out of place using them, should be deliberated.

In addition, while access to public spaces widened for white, middle- and upper-class women, access for disabled New Yorkers continued to be withheld. The dimensions of public comfort station stalls and spaces were inaccessible ever since being first erected in 1869 at Astor Place--and remained so for nearly a century, until accessibility was, at last, recognized as a human right. There were no considerations for individuals with wheelchairs, mobility impairments, or who simply did not fit the dimensions of the envisioned 'universal subject.' Disabled scholars have defined and discussed "architectural determinism," wherein form shapes space and space attempts to shape social relations.<sup>135</sup> Therefore, when public comfort stations became standardized, allowing or preventing access depending upon who needed it, they became influential over social relations. The standardization of comfort stations' dimensions materialized and made permanent the notion that public space catered to the able-bodied, leaving those marginalized without a necessary resource. Such assertions have sustained ableism within

---

<sup>135</sup> Rob Imrie, "The body, disability, and Le Corbusier's Conception of the Radiant Environment," *Disability, Space, Architecture: A Reader* ed. Jos Boys (New York: Routledge, 2017), 24.

society, wherein people with disabilities or impairments are treated as disposable, rather than integral.

The pieces of archival material analyzed throughout this chapter trace the standardization of the public comfort station into an architectural typology. This typology rested upon an intended ‘universal subject’ and, in turn, disregarded a multitude of other ‘subjects.’ The public nature of the comfort station was initially its most important characteristic; in bringing the toilet into the street, those who did not have them in their homes would ‘learn’ about hygiene. As industrialization made toilets less and less of an exclusive fixture, constructing public comfort stations became less motivated by political agendas and more by governmental offices’ perceived obligation. Modern architecture was the tool for quickly and cheaply fulfilling the governmental responsibility of providing public toilets, while simultaneously enforcing modernity’s desire for efficient movement throughout the city’s built environment. The symbolism of the public bathroom has continuously adjusted to correlate with the desire’s of a current period.

## **Disrupting the Standard: Flexible, Impermanent Architecture**

“Building forms reflect how a society feels about itself and the world it inhabits... Thus when any group that has been physically segregated or excluded protests its second-class status, its members are in effect challenging how architects practice their profession.”

Ray Lifchez, *Rethinking Architecture: Design Students and Physically Disabled People*

“Places (and spaces) both constitute and are constituted by the bodyminds, objects, practices, histories, and traces that inhabit them - and sometimes haunt them.”

Margaret Price, “Un/shared space”

In transforming public bathrooms into an easily replicable type, architects reduced the diversity of human bodies into a single standard. Architects entitled this standard ‘the user’ during the 20th century, which they constructed using the dimensions that had been outlined in the architectural handbooks born during the same period.<sup>136</sup> This ‘user’ intended to represent a ‘universal’ subject, in turn allowing architects to believe that their designs would be universally accessible and functional. However, designing around specific dimensions has an inherently “prescriptive function” by suggesting that, in order to be accommodated, you must fit certain bodily norms.<sup>137</sup>

Public bathrooms’ origins were entangled with prescriptive intentions--architects’ and planners’ intended impacts have continuously motivated their design, whether that be popularizing hygiene practices or directing efficient, ‘modern’ usage of public space. The architectural term, ‘the user,’ can be seen as an extension of the public bathrooms’ earlier, prescriptive intentions; when architects began to design public bathrooms around this established

---

<sup>136</sup> Hamraie, *Building Access: Universal Design and the Politics of Disability*, 20.

<sup>137</sup> Ibid.

‘user,’ they asserted who this space was intended for, consequently allowing it to become a symbol of broader sociocultural perceptions and, in turn, a tool of social regulation.

For those who architects exclude through the term ‘the user’--or, in other words, who diverge from architects’ established human ‘standard’--architecture naturally becomes a site of intervention, wherein its functionality relies upon a process of reclamation and repurposing. Associations, politicians and architects throughout history have treated the public bathroom as a space of pedagogy, its design guided by attempts to teach or influence behaviors or ideologies from those within. People have ignored or swayed from these ideals over time, either out of necessity or choice, demonstrating how the public bathroom, regardless of its insistent, prefixed design, can be a site of agency and individualism.

Architects participate in the assertion of certain binaries when making decisions throughout their design process: public versus private, individualized versus communal, gender separation versus integration, catering to the able-bodied versus the disabled. Public bathrooms are one architectural space that has such binaries firmly built into its structure. Though dependent upon these rigid binaries architecturally, the public bathroom has consistently been a site whose elements have been challenged and reoriented by those within. Public bathrooms attempt to control how people identify upon entry and how they will conduct themselves once within. As dedicated as architecture may be to shaping usage, usage is capable of shaping architecture. This chapter will discuss how different people--incompatible with the ‘user’ around which the public bathrooms were designed--have illustrated architecture’s flexibility, not only through their reclamations of the public bathroom, but for their consequential transformations in public bathroom design. Many of these transformations have come as a result of public bathrooms’ original architects neglecting to centralize or prioritize accessibility and diversity in

their design. While the public bathroom has been designed to guide behaviors and dynamics by symbolizing and imposing certain sociocultural beliefs, its resulting controversies have, as well.

### **The Inaccessible Public Bathroom**

Since designing the first public bathroom in New York City in 1869, architects have not constructed public bathrooms that accommodate all bodies. As public bathrooms became more common throughout the built environment in the 19th and 20th centuries, people with disabilities were “not among those populations around which the design and functionality of public toilets were organized.”<sup>138</sup> This is largely in part due to the way that city officials and administrators defined access during these periods. The administrators that were behind planning the first public comfort stations understood accessibility as providing Black, immigrant and low-income communities with access to toilets--rather than as the space being safe and usable for all. Therefore, while the white, upper class first conceived of public bathrooms in New York City as tools for popularizing their understandings of ‘hygiene,’ efficiency and gender, their architectural design catered to the able-bodied individual, suggesting that those with disabilities were not compatible with such concepts. Throughout the past few centuries, the approach that the United States has taken in treating people with disabilities has fortunately, yet gradually, shifted from one of disposability to one of accommodation. Throughout the late 20th and early 21st centuries, architecture has demonstrated its temporality and malleability, continuously evolving and shifting in response to the demands and contributions of disabled architects, people, and scholars.

Throughout the 1960s, public policy regarding disability began to take form, following decades of protests led by people with disabilities which had made the various injustices they faced visible, challenging the “out of sight out of mind” mentality that their continuous exclusion

---

<sup>138</sup> Serlin, “Pissing Without Pity: Disability, Gender and the Public Toilet,” 170.

and neglect had “served to promote.”<sup>139</sup> The American National Standards Institute developed the first (informal) accessibility standards for building codes in 1961; this “private sector model” had outlined standards for accessible features through ANSI’s “A117.1 Accessible and Usable Buildings and Facilities” guidelines.<sup>140</sup> While some states began drawing from this model to develop accessibility requirements within their own construction projects, accessibility remained largely unregulated and inconsistent across the country.<sup>141</sup> As a result, Congress enacted the first federal law to address accessibility in 1968, the Architectural Barriers Act (ABA). The ABA required that any facilities designed, built, altered, or leased with federal funds--such as post offices or courthouses--were accessible for people with disabilities.<sup>142</sup> Hugh Gallagher, an aide to Senator E.L. Bartlett, introduced and drafted the ABA; as a wheelchair user who experienced firsthand the barriers to access, Gallagher wanted accessibility to be “one of the items on the checklist of designers and and builders.”<sup>143</sup>

In 1968, noticing, again, uneven compliance of the ABA across the country, Congress formed the Access Board, both to directly enforce the ABA and to propose additional solutions to architectural barriers.<sup>144</sup> Some of the Access Board’s proposals included calls for making toilets more accessible--such as innovating toilet design through grab bars, enlarged stalls and

---

<sup>139</sup> Arlene Mayerson, “The History of the Americans with Disabilities Act A Movement Perspective,” *Disability Rights Education & Defense Fund*, 1992, <https://dredf.org/about-us/publications/the-history-of-the-ada/#:~:text=On%20May%209%2C%201989%20Senators,multi%2Dlayered%20strategy%20for%20passage.>

<sup>140</sup> “History of Accessible Facility Design,” *Whole Buildings Design Guide*, last updated July 18, 2019, <https://www.wbdg.org/design-objectives/accessible/history-accessible-facility-design#:~:text=The%20first%20nationally%20recognized%20accessible,the%20Easter%20Seals%20Research%20Foundation.>

<sup>141</sup> Lance Robertson, “Celebrating 50 Years of the Architectural Barriers Act,” *Administration for Community Living*, September 7, 2018, <https://acl.gov/news-and-events/acl-blog/celebrating-50-years-architectural-barriers-act.>

<sup>142</sup> *Ibid.*

<sup>143</sup> “History of the U.S. Access Board,” *U.S. Access Board Advancing Full Access and Inclusion For All*, <https://www.access-board.gov/about/history.html#:~:text=1973%20%E2%80%93%20The%20Access%20Board%20is%20Created&text=A%20provision%20in%20the%20law,and%20Transportation%20Barriers%20Compliance%20Board.>

<sup>144</sup> *Ibid.*

lowered sinks.<sup>145</sup> However, the ABA limited the installation of such accommodations to private homes or institutions. Congress's attempts at increasing the accessibility of the United States' built environment was, generally, limited progress, as it pertained predominantly to federal facilities and only extended as far as the problematic institutions that doctors and hospitals had established for people with disabilities, leaving the rest of the country largely inaccessible.

After years of the disability community successfully fighting several "disability-specific negative Supreme Court rulings," educating U.S. courts on the multitude of issues within disability-based discrimination, and coordinating national campaigns to encourage passing of non-discrimination legislation, the National Council on Disability--an independent federal agency whose members were appointed by President Reagan--proposed the first draft of the American with Disabilities Act (ADA) in 1988.<sup>146</sup> Throughout the next year, the disability community mobilized, assembling the Consortium for Citizens with Disabilities (CCD), which consisted of disability organizations, civic organizations, teams of lawyers and advocates. The CCD continuously negotiated with and informed members of Congress and their staff so as to ensure that the ADA was not only passed by Congress, but that CCD would play a role in its drafting.<sup>147</sup> The passing of the ADA came as a direct result of hundreds of disabled people climbing the steps of the U.S. Capitol Building in Washington, D.C. after leaving behind "wheelchairs, scooters, canes, and crutches," a protest known as the "Capitol Crawl."<sup>148</sup>

Once Congress signed the ADA into law in July 1990, the guidelines that the Access Board had been outlining for years prior--such as their "Uniform Federal Accessibility Standards," published to assist in the enforcement of the ABA--began being shared with, and

---

<sup>145</sup> Serlin, "Pissing Without Pity: Disability, Gender and the Public Toilet," 171.

<sup>146</sup> Ibid.

<sup>147</sup> Ibid.

<sup>148</sup> Hamraie, *Building Access: Universal Design and the Politics of Disability*, 198.





Congress's passing of the ADA demonstrated that an attunement to accessibility was now mandatory throughout the country's built environment. Yet, the ADA's interpretation of this attunement was through the abidance of specific, static building standards, rather than examining the ableism inherent to many architectural design and construction processes and exploring potential alternatives. When The International Code Council (ICC) was formed in 1994, as a non-profit organization "dedicated to developing a single set of comprehensive and coordinated national model construction codes," it represented a slightly different relationship with accessibility standards.<sup>151</sup> While the ADA was a civil rights law that served to prohibit discrimination against people with disabilities "in all areas of public life," the ICC was a source of multiple models, standards and potential solutions that architects and engineers could draw from. In other words, while the ADA stated particular requirements for architects to abide by, the ICC--formed by three different organizations that had already each developed their own sets of model codes--intended to be a resource throughout the construction process of facilities or fixtures, offering various standards that would ensure accessibility.<sup>152</sup>

The ICC worked with and built off of the ANSI A117.1, merging in 1999 and becoming renamed the ICC A117.1.<sup>153</sup> There are various differences between the provisions of the ADA and the ICC, and both continue to be revised every few years. One example of the variations between the ADA and the ICC regarding public bathrooms is that while the ADA requires the

---

<sup>151</sup> "Overview," *International Code Council*, [https://www.iccsafe.org/about/overview-2/#:~:text=The%20International%20Code%20Council%20\(ICC,and%20Code%20Administrators%20International%2C%20Inc.](https://www.iccsafe.org/about/overview-2/#:~:text=The%20International%20Code%20Council%20(ICC,and%20Code%20Administrators%20International%2C%20Inc.)

<sup>152</sup> "ANSI vs. ADA," *Abadi Accessibility*, January 4, 2016, <http://abadiaccess.com/ansi-vs-ada/>

<sup>153</sup> "Design and Construction Requirements; Compliance With ANSI A117.1 Standards," *Federal Register The Daily Journal of the United States Government*, October 24, 2008, <https://www.federalregister.gov/documents/2008/10/24/E8-23785/design-and-construction-requirements-compliance-with-ansi-a1171-standards>; "Should I Still Be Concerned About ICC A117.1?" *Wagner Collaborative Metal Works*, <https://wagnercompanies.com/ansi-a117/#:~:text=With%20the%20merging%20of%20the%20version%20is%20the%202009%20edition.>

installation of one grab bar, the ICC A117.1 states that “grab bars shall be provided on the rear wall and on the side wall closest to the water closet,” while also providing four different approaches to installing grab bars (Fig 3.2, Fig. 3.3).<sup>154</sup> The ADA has viewed accessibility as the abidance to specific, instated rules, whereas the ICC has exemplified various standards or approaches that can be utilized to construct accessible spaces and fixtures. These developments in public policy and construction code illustrate how government officials’, architects’ and engineers’ establishment of accessibility standards--such as those for public bathrooms--viewed accessibility as a separate, rather than an inherent, component to the architectural design process.

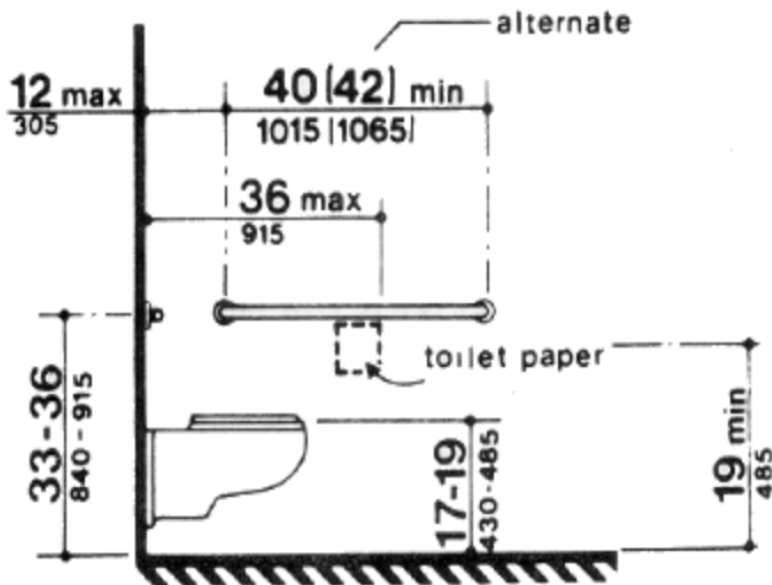

Figure 3.2: Department of Justice, “4.17.6 Grab Bars,” *ADA Standards for Accessible Design*, 1991.

<sup>154</sup> “Section 603 Toilet and Bathing Rooms,” *2017 ICC A117.1 Accessible and Usable Buildings and Facilities*, <https://codes.iccsafe.org/content/ICCA11712017P2/chapter-6-plumbing-elements-and-facilities>.

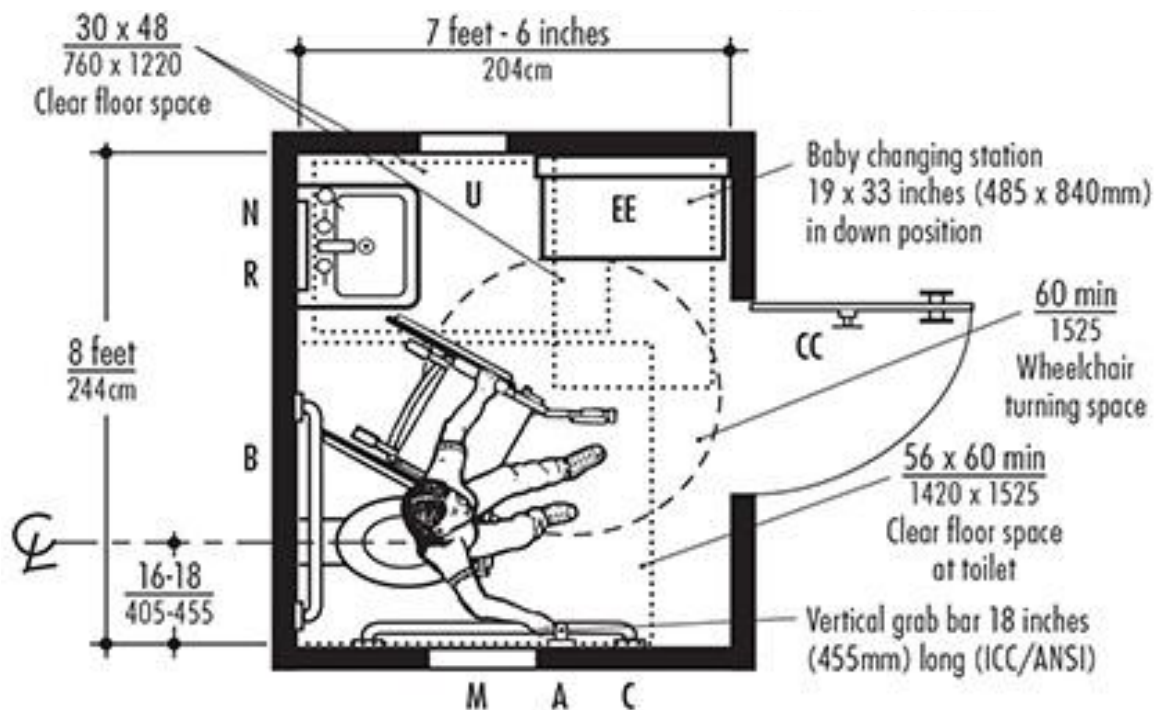

Figure 3.3: International Code Council, “604.7.1 (A),” Grab Bars with Dispenser Below, *2017 ICC A117.1 Accessible and Usable Buildings and Facilities*, 2017.

While the ADA and the ICC led public bathrooms to becoming moderately more accessible--although centuries overdue--the codes and standards they have required rely upon a “presumption of equality.”<sup>155</sup> By inserting ‘add-ons,’ such as grab bars or enlarged stalls, the public bathroom could be regarded as an “equal playing field.”<sup>156</sup> This resembles the broader “discourse of equality” within the United States, which is often implemented as “a blunt instrument used to flatten difference.”<sup>157</sup> The construction of more accessible toilets, tucked within accessible stalls--of which there is usually only one--upholds elements of able-bodied culture by obscuring the fact that independence and individualism are not universal experiences.<sup>158</sup> Though such standards have increased the inclusivity of the public bathroom, they did so by upholding the same ableist convictions that led to their inaccessibility in the first

<sup>155</sup> Serlin, “Pissing Without Pity: Disability, Gender and the Public Toilet,” 169.

<sup>156</sup> Ibid.

<sup>157</sup> Ibid.

<sup>158</sup> Ibid., 174.

place--that disability requires its own, isolated, spaces, apart from the rest of the public. The ways that government officials, architects and engineers have treated disability, within architecture and the public bathroom, has illustrated how “built environments serve as litmus tests of broader social exclusions.”<sup>159</sup>

The construction of such policies and standards characterized accessibility as accessories, or as ‘add-ons,’ relying upon “minimum guidelines” to transform the ableism within the built environment.<sup>160</sup> As a result, disabled architect Ronald Mace introduced the idea of “universal design” in 1985, which imagined “a way of designing a building or facility at little or no extra cost, so that it is both attractive and functional for all people, disabled or not.”<sup>161</sup> A key argument within Mace’s idea of Universal Design was that the “recent trends toward... ‘special’ or ‘handicapped’ products and spaces,” which were often designed with an “institutional appearance,” did not permit “a greater awareness of spatial misfit with disability at its center.”<sup>162</sup> Mace wanted to illustrate how “disability-focused” design did not need to be inherently “institutional” or “aesthetically displeasing,” but that stigmas towards disability had enforced such a narrow approach to accessible design.<sup>163</sup> Mace further complicated architects’ traditional approach to accessible design by asserting disabled people as “powerful knowers” and “political agents,” rather than “passive, disempowered users,” arguing for their inclusion, and an acknowledgment of their agency, throughout the design process, rather than just their dimensions.<sup>164</sup> Whereas the standards of the ADA and the ICC brought the notion of accessibility into the built environment, Mace demonstrated that inclusive design needed to take form beyond

---

<sup>159</sup> Aimi Hamraie, “Designing Collective Access: A feminist disability theory of universal design,” in *Disability, Space, Architecture, A Reader* ed. Jos Boys (New York: Routledge, 2017), 79.

<sup>160</sup> Hamraie, *Building Access: Universal Design and the Politics of Disability*, 200.

<sup>161</sup> *Ibid.*, 175.

<sup>162</sup> *Ibid.*, 182.

<sup>163</sup> *Ibid.*

<sup>164</sup> *Ibid.*

the mere implementation of codes and regulations, but throughout the entire design process and discipline of design and architecture.

A central argument behind Universal Design was that the most accessible designs were “so materially ‘subtle’ and ‘so well integrated that they become indistinguishable from mainstream design.’”<sup>165</sup> Therefore, while the ADA relied upon the application of fixtures and standards that highlighted difference--such as alternative stalls and toilets--Universal Design incorporated and embraced difference throughout the entire design process so that it was indistinguishable within the final product. One result of the distinction that Universal Design drew between its approach and that of the ADA is the unisex, accessible ‘family restroom,’ which has become “a symbol of broad accessibility” for a variety of marginalized groups--such as disabled, trans, queer or homeless people--for whom this style of restroom allows their various needs to be comfortably met.<sup>166</sup> Mace’s concept of Universal Design, as well as other substantial work led by disabled architects, designers and people, illustrated the demarcating powers of architectural design, and the approaches available for remedying the harms this had caused.

### **The Binary Public Bathroom**

While architects initially designed ‘the user’ around a male, able-bodied person, throughout the second half of the 20th century, newer editions of architectural handbooks began adding dimensions “for children, women, and finally ranges of people’s heights as well as people in wheelchairs” (Fig 3.5, Fig. 3.6).<sup>167</sup> Yet, in expanding the identity of the ‘user,’ binaries became further entrenched into architecture, encouraging architects to approach designs for men and women, and able-bodied and disabled people, differently--solidifying and normalizing these

---

<sup>165</sup> Ibid., 201.

<sup>166</sup> Ibid., 205.

<sup>167</sup> Paul Emmons and Andreea Mihalache, “Architectural handbooks and the user experience,” 47.

binaries within the built environment. The ‘user’ was now either a man or a woman, able-bodied or disabled--your experience within architecture became further influenced and controlled by your identity.

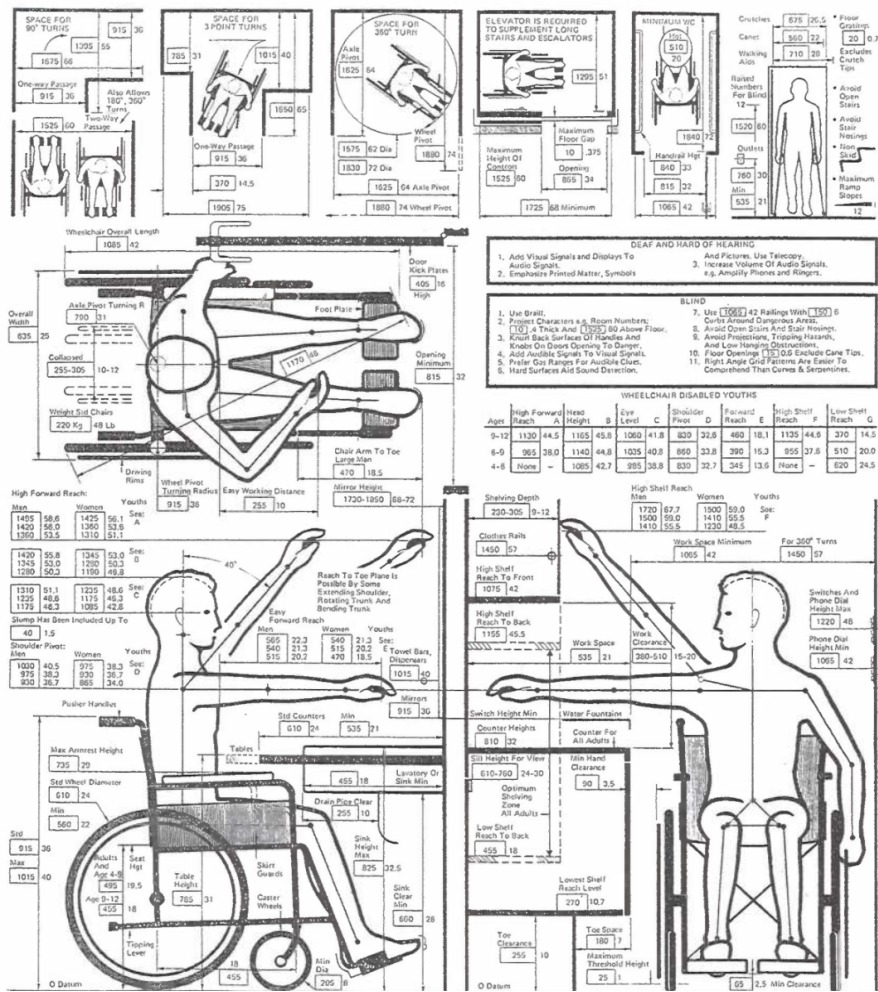

Figure 3.5: Drawings of “anthropometric figures representing disability,” in *Architectural Graphic Standards* 7th ed., 1981. Found in *Building Access: Universal Design and the Politics of Disability*. Minneapolis: University of Minnesota Press (2017): 32.

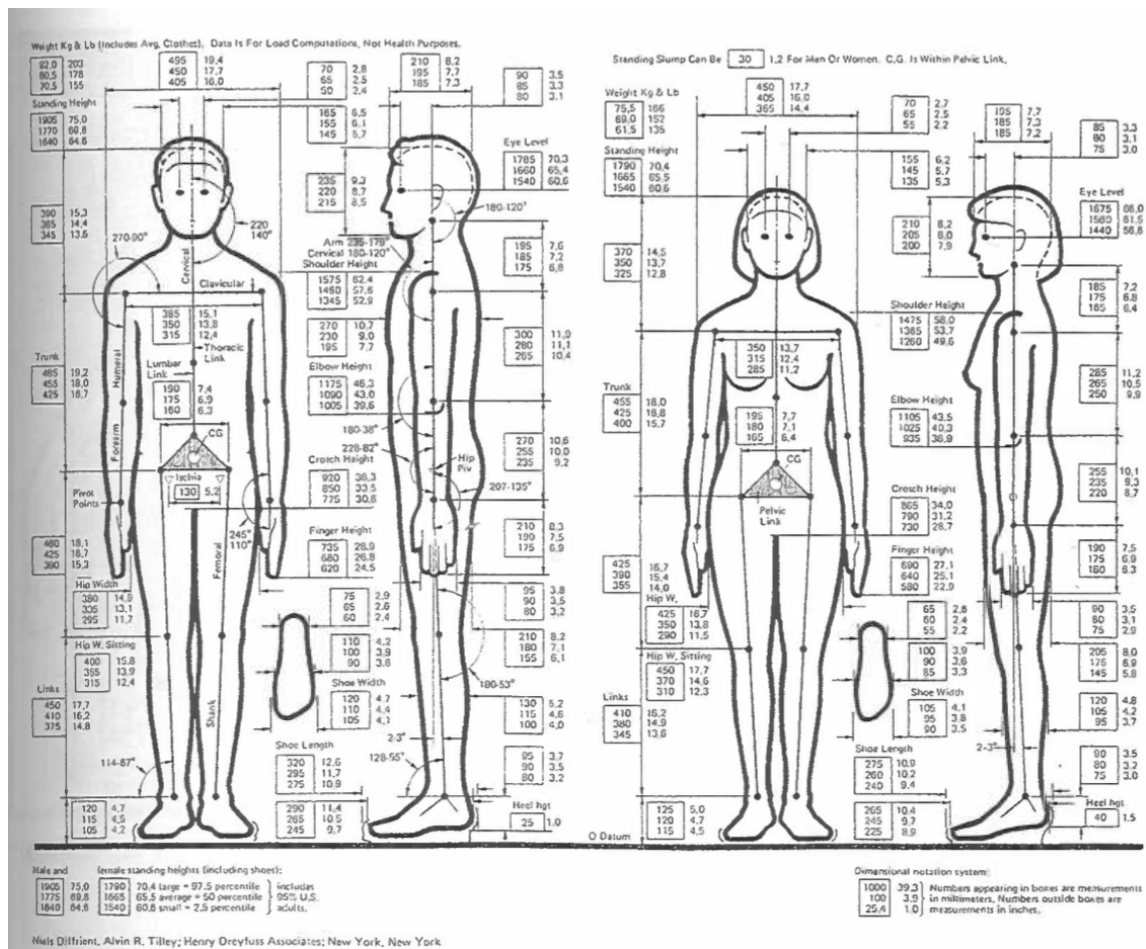

Figure 3.6: Drawings of “anthropometric figures, such as Joe and Josephine,” in *Architectural Graphic Standards* 7th ed., 1981. Found in *Building Access: Universal Design and the Politics of Disability*. Minneapolis: University of Minnesota Press (2017): 31.

The public bathrooms’ separation of men’s and women’s sections became intensified by the 20th-century development of a “new science of sex differences,” in which biological markers were employed for defining, and determining, ‘gendered bodies.’<sup>168</sup> Biological qualities began to enact legislative and institutional shifts, supported by claims of ‘protecting’ women who were now being deemed as biologically weaker, in body and mind, than men.<sup>169</sup> For architects to

<sup>168</sup> Davis, “The Hidden Privilege in Potty Politics,” 37.

<sup>169</sup> *Ibid.*, 38.



ensure women were being kept ‘safe’ and ‘modest’ in public bathrooms and other seemingly ‘vulnerable’ spaces--like changing rooms--women were to be kept separate from men. However, the pleas for separate spaces for women were coming from white, cisgendered upper-class women. Therefore, while this demographic felt ‘safer’ and more ‘protected’ when provided spaces separate from men, anybody outside of their narrow demographic could disrupt this safety. Further, most people have only applied biology when constructing arguments around womens’ fragility to white, cisgender women, and has simultaneously been used to exclude, ostracize and diminish the rights of other women, such as Black women, women of color and trans women.

While, initially, the employment of biology ‘proved’ that women needed their own, separate spaces from men, it has simultaneously been utilized to determine who can and cannot be considered a woman--in general, and within such spaces. Throughout the 1940’s and 1950’s, upper-class, white women fought against legislation around racial integration by arguing both that integration would grant Black men “sexual access to them,” and that proximity to Black women “would infect them with venereal diseases,” often refusing to use integrated public bathrooms on such grounds.<sup>170</sup> The societal desire for public bathrooms’ gendered segregation was therefore never about legitimate gender differences between men and women--it was about the protection of white supremacist ideologies that categorized anything non-white as dirty or dangerous. Therefore, the gendered public bathroom relies upon a historic “protectionism” that “implicitly and explicitly casts others as threats to public safety.”<sup>171</sup> The implementation of

---

<sup>170</sup> Gillian Frank, “The Anti-Trans Bathroom Nightmare Has Its Roots in Racial Segregation,” *Slate*, November 10, 2015, <https://slate.com/human-interest/2015/11/anti-trans-bathroom-propaganda-has-roots-in-racial-segregation.html>; Eileen Boris, “‘You Wouldn’t Want One Of ‘Em Dancing With Your Wife’: Racialized Bodies on the Job in World War II,” *American Quarterly* 50 no. 1 (1998), <https://muse.jhu.edu/article/175687>.

<sup>171</sup> Toby Beauchamp, *Going Stealth: Transgender Politics and U.S. Surveillance Practices*, 84.

biology within this method of ‘protectionism,’ enforced through architectural binaries and boundaries, has also enabled the categorization of trans men and women as public threats.

Throughout the 21st century, bathroom policies, ordinances and legislation throughout the country have alternated between either expanding and limiting access on the basis of gender and safety. Opponents to gender-inclusivity within public bathrooms, from politicians to conservative cisgender people, have cited fears of “sexual predators” who could use “the guise of gender confusion to enter the restroom.”<sup>172</sup> The transformation of blatant transphobia--defined as a collection of ideas encompassing a range of negative attitudes, feelings, or actions towards transgender people or transness in general--into a call for public safety led to the Public Facilities Privacy & Security Act, passed by the North Carolina General Assembly in 2016.<sup>173</sup> This was the first state law that addressed trans people’s access to public bathrooms, stating that “individuals must use the restroom that corresponds with the designated sex listed on their birth certificates when in government buildings, such as schools.”<sup>174</sup>

This law caused national protest, leading the newly elected governor of North Carolina to repeal it in 2017--though by simultaneously replacing it with House Bill 142, which granted the General Assembly “exclusive power in regulating access to multiple occupancy restrooms and changing facilities” while also preventing local governments from passing any non-discrimination ordinances for the next three years.<sup>175</sup> Though the language may have changed, the intention remained the same--trans people were revoked of the right to use the public bathroom that felt more comfortable for them. The term ‘cis’ (short for cisgender) comes from the latin meaning “on the same side as,” and is used to refer to people whose gender is the

---

<sup>172</sup> Kristen Schilt and Laurel Westbrook, “Bathroom Battlegrounds and Penis Panics,” *Contexts* 14 no.3 (2015): 29.

<sup>173</sup> Brian Barnett, Ariana E. Nesbit and Renée M. Sorrentino, “The Transgender Bathroom Debate at the Intersection of Politics, Law, Ethics, and Science,” *Journal of the American Academy of Psychiatry and the Law Online* 46 no. 2 (2018): 232.

<sup>174</sup> *Ibid.*

<sup>175</sup> *Ibid.*, 233.

same as the gender that was presumed for them at birth, whereas the term ‘trans’ (short for transgender), coming from the latin meaning “on the opposite side as,” is used to refer to people whose gender is not the same as the gender that was presumed for them at birth.<sup>176</sup> To be trans, by definition, situates you as on the ‘opposite’ side. This opposition conflicts with the structure of public bathrooms, in which societal pressure has been continuously placed on using one’s ‘correct’ side.

By citing the “harm principle”--suggesting that allowing trans people to use the public bathroom that aligns with their gender identity will lead to harm, danger and violence--trans people’s autonomy has been revoked. By centralizing the potential for harm, trans people’s ability to use public bathrooms has been placed in the hands of security guards, administrators or politicians, rather than their own. This is reminiscent of other, various moments throughout U.S. and New York City history, when policing or legislative measures have been used to control or deny certain demographics access to public bathrooms. There has been little to no evidence over time that trans-inclusive public bathrooms have led to any cases of sexual assault, harassment, pedophilia, or predator-like behavior enacted by trans people.<sup>177</sup> Regardless of the limited truth behind this ‘harm principle,’ exclusionary beliefs and legislation targeted towards trans people has heightened the pressure of “learning the social codes” of public bathrooms.<sup>178</sup> In order to avoid facing the harassment that they have been accused of perpetrating, trans people have had to ensure that they will societally ‘pass’ as the gender that they identify as.

Yet, ‘passing’ is oftentimes most associated with taking hormones or completing gender affirming surgeries--both of which are expensive and oftentimes incompatible with insurance

---

<sup>176</sup> “What Does Cis Mean?” *Trans Hub*, <https://www.transhub.org.au/101/cis>.

<sup>177</sup> Barnett, Nesbit, Sorrentino, “The Transgender Bathroom Debate at the Intersection of Politics, Law, Ethics, and Science,” 235.

<sup>178</sup> Barcan, “Dirty Spaces,” 33.

coverage. This is paired with the fact that trans people face double the rates of unemployment compared with the general population and, more generally, face severe levels of social and economic discrimination, all of which are intensified for Black trans people and trans people of color.<sup>179</sup> The binary model of public bathrooms does not leave room for gender exploration, variance or diversity, instead centralizing conformity--resembling how the first public comfort stations intended to 'Americanize' the immigrant communities they were directed at. To be granted safe and comfortable access to the side of the public bathroom that you identify with, you must 'pass' as that gender, or conform to the ways that society has envisioned that gender would present. Therefore, in recent years, architects, designers and activists have proposed crafting "a new kind of public bathroom---and ultimately a new form of public space---that allows people to become aware of and accept multiple forms of gender expression" while also, mainly, allowing people of all genders to exist comfortably.<sup>180</sup>

Rather than utilizing the established model for the public bathrooms as a battleground over safety between cis and trans people, these proposals suggest creating an entirely new architectural model for public bathrooms, that presents gender as a spectrum rather than a binary. Such proposals vary from suggesting single-stall public bathrooms to suggesting "one single open space with fully enclosed stalls."<sup>181</sup> The first proposal, single-user or single-stall public bathrooms, is the "generally accepted code-compliant solution," explained by its adherence to the "status quo."<sup>182</sup> Though providing access to a range of people, the single-user design "spatially isolates and excludes," by preventing those that choose to use this public bathroom from "mixing with other people."<sup>183</sup> At the same time, this isolation may provide privacy that

---

<sup>179</sup> Ibid., 30.

<sup>180</sup> Joel Sanders and Susan Stryker, "Stalled: Gender-Neutral Public Bathrooms," *The South Atlantic Quarterly* 115:4 (2016): 781.

<sup>181</sup> Ibid., 783.

<sup>182</sup> "Design," *Stalled!* <https://www.stalled.online/approaches>.

<sup>183</sup> Sanders and Stryker, 783.

such people--especially trans, gender fluid and houseless people--would not experience in multi-stall public bathrooms, due to societal stigmas and judgments.

The “multi-user” design that architects have proposed characterizes itself as “getting rid of typical gender segregated facilities that are characterized by American-style stalls whose revealing gaps, at floor, ceiling and doors compromise visual privacy.”<sup>184</sup> This design, instead, proposes designing the public bathroom as an open space with doors that ensure visual and acoustic privacy (Fig. 3.7). The designers behind this proposal believe that “by consolidating a greater number of people in one rather than two rooms, there are more eyes to monitor, reducing risk” for trans or gender fluid people while also facilitating “care-giving” between “ages, genders and disabilities.”<sup>185</sup>

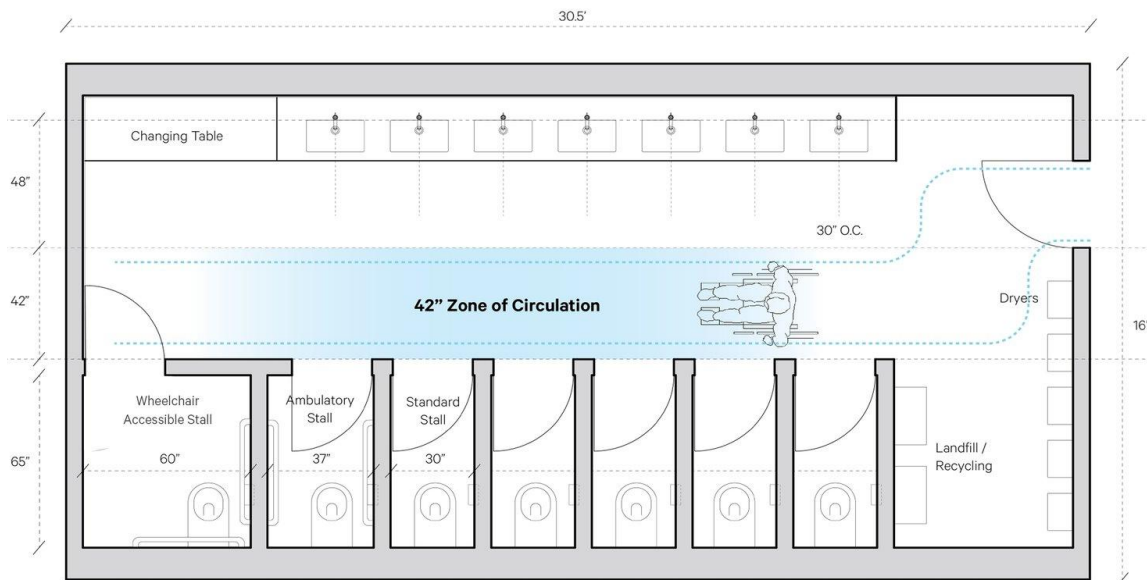

Figure 3.7: Stalled! “Multi-User Solution.”

<sup>184</sup> “Multi-User Solution,” *Stalled!* <https://www.stalled.online/approaches>.

<sup>185</sup> Sanders and Stryker, “Stalled: Gender-Neutral Public Bathrooms,” 783.

The optimistic, perceived benefits of the ‘multi-user solution’ have yet to be confirmed, since this organization has not designed this proposal so as to be code-compliant, therefore they have not actually been able to construct it. It is interesting to consider how a proposal that intended to centralize inclusivity and access failed to incorporate code-compliance from the start of the design process. Nevertheless, both proposals provide insight into potential solutions or approaches to mediating the harmful stigmas that public bathrooms designed according to the gender binary have caused and can continue to cause.

While the first public bathrooms materialized societal beliefs that gender was a binary, and architects and planners have continued to design it according to this logic, proposals of this kind demonstrate how architectural assertions are capable of shifting in response to societal need and social culture. Gender-neutral public bathrooms can expand the “architectural implications” of gender that the current, anticipated model of public bathrooms have declared.<sup>186</sup> Moreover, in whatever form they take, public bathrooms can not only symbolize sociocultural ideals, but encourage certain outlooks, behaviors and dynamics as a result. The binary design of the public bathroom has been defended throughout history using racist or transphobic sentiments that rest upon the vulnerability felt regarding one’s partially-naked body in close proximity to others’. Altering this established structure would motivate a new dynamic, and new beliefs, regarding this vulnerability. However, that is not to say that there have not already been alternative relationships with the vulnerability felt in public bathrooms.

### **The Homoerotic Public Bathroom**

The ‘protectionism’ that cis people have cited and weaponized in public bathroom debates also stems from heteronormative ideologies which presume that “young, unmarried

---

<sup>186</sup> Ibid., 782.

women working outside the home needed separate restrooms to maintain their modesty and privacy in public.”<sup>187</sup> If men and women were to share the same public bathroom facilities, men could “fall prey to a slippery slope of moral degeneracy that would draw them away from their jobs and families entirely.”<sup>188</sup> This rhetoric positioned (cis) women as inherently sexual subjects in need of protection, and (cis) men as uncontrollable sexual predators in need of restraint. Providing men and women with distinct bathroom facilities was an attempt at supervising and controlling such heteronormative dynamics--the lack of consideration over non-heterosexual people within this regulatory architecture left room for opportunity. Though architects, planners and administrators have consistently designed public bathrooms to control or prevent certain behaviors or dynamics, their focus on regulating certain demographics over others has encouraged their reappropriation, demonstrating the symbiotic and flexible relationship between society and architecture.

Liam Nolan has discussed how “identifying as gay not only has a sexual component, but it also instructs the way the body is located in space, where it can be queer, and how connections form to other gay men in space,” all of which depend on one’s class, race, gender and if they are ‘out’ or not.<sup>189</sup> Starting in the 19th century, gay men reappropriated the men’s sections of public bathhouses and comfort stations in New York City into spaces for gay sex and pleasure. This reconfiguration of initially sanitary spaces into spaces of sexuality exemplifies how public spaces allow people to “claim their right” regardless of intended function.<sup>190</sup> Men claimed this right to sex and pleasure in public--whether married and closeted, single and closeted, young and closeted, kicked out by their parents for not being closeted, or else a range of other realities or

---

<sup>187</sup> Davis, “The Hidden Privilege in Potty Politics,” 38.

<sup>188</sup> Ibid.

<sup>189</sup> Liam Nolan, “The Piers: the Ruins of the West Side,” in *From the Church of Disco to Waterfront Ruins: An Analysis of Gay Space* (BA Thesis: Bard College, 2019): 59.

<sup>190</sup> George Chauncey, *Gay New York: Gender, Urban Culture, and the Making of the Gay Male World, 1890-1940*, (New York: BasicBooks, 1994), 179.

perhaps for no particular reason at all, public bathhouses and comfort stations provided windows of privacy, secrecy and gratification. Chauncey argues that throughout the 19th century, a “finely calibrated sexual map of the city” developed, identifying which bathrooms were the safest for meeting and pursuing other men.<sup>191</sup> Regardless of how systematized and coded such activities had become, surveillance and policing measures followed quickly behind them; as early as 1896, police officers made a large sum of arrests in response to certain public comfort stations becoming regular sites for gay pleasure.<sup>192</sup>

A process of surveillance and counter-surveillance formed in which, the harder police forces attempted to catch gay activity, the more concealed and systematic it became. “Nonverbal signs” became a tool for both confirming mutual interest and for warning others in the midst of, or prior to, engaging in pleasure that strangers were approaching.<sup>193</sup> Simultaneously, gay men were drawing upon the architecture of public comfort stations to obscure the view of sexual activities. Reclaiming the privacy that stalls offered, or employing the corners of comfort stations, men found ways to reappropriate the interiors of public comfort stations into spaces of exploration, excitement and indulgence. As such counter-surveillance measures spread, policing intensified--policemen would hide outside of the comfort stations known for gay sex and pleasure, or hide “behind the grill facing the urinals,” or alternatively, send plainclothesmen to “entrap” men by expressing interest towards those inside, and then arresting them.<sup>194</sup>

Though the counter-surveillance measures that men had created did not eradicate the lingering threat and danger that the police posed, they constructed a sense of community and belonging between the men involved. The commitment to keeping one another safe and

---

<sup>191</sup> Ibid., 195.

<sup>192</sup> Ibid., 196.

<sup>193</sup> Ibid., 197-198.

<sup>194</sup> Ibid.



un-discovered forged relationships of trust and respect within the “sexual underground,” while the scene itself demonstrated to closeted or young gay men the “enticing...scope of the gay world and of its counterstereotypical diversity.”<sup>195</sup> While city police forces utilized surveillance and punishment to delineate what was or wasn’t permissible in public space, the architecture of public bathrooms provided the grounds for people to break these rules regardless, and strengthen community bonds as a result.

The association between public bathrooms and gay sexual activity intensified during the late 20th century with the HIV/AIDS crisis and the consequential homophobic panic it evoked from straight people.<sup>196</sup> Throughout the late 1980s and 1990s, medical researchers spread various forms of misinformation, fueling such panic, including that HIV/AIDS could be spread via toilet seats--which has been proven to be both incorrect and impossible, but which at the time led to the closing of an “overwhelming majority” of public bathrooms across the U.S.<sup>197</sup> New York City was not an exception. However, the escalation of punitive measures against gay men’s right to public bathrooms did not remove the eroticism of the men’s room entirely. Sexuality continues to be a tension floating within the interior of the men’s bathroom; scholars and designers have characterized the design of the men’s section as “a carefully orchestrated *visual* technology aimed at testing and policing masculine sexuality.”<sup>198</sup>

As opposed to how architects and planners have structured the women’s room around a line of stalled toilets, they have designed the men’s room as an open space--structured around the hardly-partitioned, if at all, urinal--intensified by its mirrored walls, enforcing a “vigilant nonchalance” from those within so to prohibit their gaze from shifting from the ‘normative’

---

<sup>195</sup> Ibid., 200.

<sup>196</sup> Davis, “The Hidden Privilege in Potty Politics,” 40.

<sup>197</sup> John Tierney, “The Big City; In 80’s, Fear Spread Faster Than AIDS,” *New York Times*, June 15, 2001, <https://www.nytimes.com/2001/06/15/nyregion/the-big-city-in-80-s-fear-spread-faster-than-aids.html>; Davis, 40

<sup>198</sup> Barcan, 39.

(heterosexual) to the threatening (gay) (Fig. 3.8).<sup>199</sup> While nonverbal cues once enabled the repurposing of public bathrooms into space of pleasure, they now serve to prevent, or subtly warn against, this pleasure from creeping in. Further, while the architectural design of the men's room initially aided its appropriation into a site of sexual pleasure, it now functions to test those within, of the sexual tension it produces.



Figure 3.8: Row of urinals in a public bathroom, photograph by Mark Hamel.

Within the men's room, one's gaze has served as both as a technique for pursuing, and a threat of warning against, gay pleasure, a tense and fragile dynamic motivated by its open design. The women's room, which architects have consistently structured around rows of partitioned stalls, has had a similar history with its design being appropriated for pleasure, and policing

---

<sup>199</sup> Ibid.

measures following as a response. Joan Nestle--lesbian author, and cofounder of the Lesbian Herstory Archives--wrote a poem entitled "Stone Butch, Drag Butch, Baby Butch," where she writes of her experiences in public bathrooms, where "tuned for the intrusion," she and her lover "made love in a public place because territory was limited."<sup>200</sup> In an email correspondence with Nestle, she recounted the importance that public bathroom stalls had for lesbians, in which "doors could be locked," significant for lesbians who lived "without privacy, did not have cars, and did not have a place to bring one night stands or lovers."<sup>201</sup> These statements are reminiscent of the conditions that led gay men to their appropriation of public comfort stations--the privacy that public bathrooms' design has centralized has simultaneously served the needs of people for whom privacy was a luxury.

Yet, the sense of safety that locked stalls provided lesbians did not go undisturbed--Nestle notes how "experienced butches used the bathroom stalls in Riis Park's women's toilets always with a shopping bag on hand so their sexual partners could stand in the bag and escape the prying eyes of the police women who patrolled our beach."<sup>202</sup> Just as gay men had to create a shared language of cues and signals to avoid police officers 'catching' and punishing them, lesbians, too, constructed creative means for transforming the stalls of the public bathroom into spaces of secret, private pleasure. As gay men had to be careful to dodge undercover cops, or straight men that would call the cops if caught in the act, within the men's room, Nestle recounts how police officers and attendants monitored lesbian "bathroom habits," even within New York's lesbian bars: "only one woman at a time was allowed into the toilet because we could not be trusted."<sup>203</sup> While the architectural design of public bathrooms made room for opportunity and privacy, it

---

<sup>200</sup> Joan Nestle, *A Restricted Country* (Ithaca: Firebrand Books, 1987), 76.

<sup>201</sup> Joan Nestle, email to author, April 11, 2022.

<sup>202</sup> Ibid.

<sup>203</sup> Nestle, *A Restricted Country*, 38.

simultaneously left space for intrusion. Architects and planners continue to design the women's room around stalls, their gaps reveal the pair, or pairs, of feet within.

Architects have designed public bathrooms to manage behaviors and dynamics since their inception. Throughout various periods, architects, planners, and government officials have directed such regulatory intentions at different demographics and for different purposes. During the 20th-century, the formulation of architectural handbooks led to the notion of 'the user,' transforming architectural design substantially into processes of standardization--suddenly, spaces became designed around a constructed 'universal subject,' that was either male or female, able-bodied or disable, and consistently imagined to be straight and cis. The 'mass subject' that buildings began being designed around was incompatible and incongruent with many people's actual bodies and realities. Regardless of what architecture has been designed to shape, people have continued to reshape architecture as a response.

# Epilogue

“Restroom equity doesn’t get the attention that it deserves, but it’s a critical human rights issue.”

Rita Joseph, New York City Council Member



Figure 4.1: *Urban Design Forum*, map of public bathrooms in New York City, 2019.

In a city with a population of over 8 million people, there are only 1,103 public bathrooms in New York City, only four of which are open 24/7 (Fig. 4.1).<sup>204</sup> It is a public health crisis, and human rights issue, left unmanaged and widely ignored. This statistic, in and of itself, illuminates how New York City officials, administrators and planners do not treat public bathrooms as a priority. Yet, this thesis has demonstrated how these actors have never constructed public bathrooms with a prioritization of access, care or support; instead, they have treated public bathrooms as a means for controlling and regulating bodies, behaviors and dynamics throughout different moments in history--in some periods more explicitly than others. The lack of public bathrooms in New York City witnessed today is one symptom of these origins. Public bathrooms have never come as a response to or acknowledgment of public need, but are instead motivated by governmental and administrative agendas. Now, public bathrooms are simply absent from, or at the very bottom of, these agendas.

Regardless of their scarcity, public bathrooms' architectural design continues to exemplify the distinction between support and control. They continue to be a site of pedagogy, where usage is guided through placards and signage, reminding you of how you should, and shouldn't, be conducting yourself (Fig 4.2). They continue to be a site of reflection, in which one's identity and social standing is reflected back at them--figuratively, and literally, within a room consumed by wall-filled mirrors and unspoken social codes. Individuals in positions of authority still implicitly regulate and enforce such unspoken, internalized social codes. For example, park managers and security officers continue to lock public bathrooms at night, preventing those that are houseless from using them when they need to. In addition, those designing public bathrooms have continued to go lengths to prevent them from becoming sites of

---

<sup>204</sup> Chou, Gurley, Hong, "The Need for Public Bathrooms."

substance use, either through explicit placards, or more direct measures, such as installing blue lighting so drug users are unable to see their veins when injecting.<sup>205</sup>



Figure 4.2: A waste basket within a public bathroom in New York City displays two visuals--one showing a hand discarding a menstrual product, and the other showing a syringe, often associated with drug injection, crossed out in red.

---

<sup>205</sup> Lindsey Bever, “A plan to keep drug users from shooting up in public restrooms — and why it may be a bad idea,” June 29, 2018, *The Washington Post*, <https://www.washingtonpost.com/news/to-your-health/wp/2018/06/29/the-plan-to-keep-drug-users-from-shooting-up-in-public-restrooms-and-why-it-may-be-a-bad-idea/>.



This thesis illustrates how public bathrooms in New York City have been guided by architects', planners' and politicians' centralization of sociocultural beliefs regarding the 'cleanliness' and utility of the 'user,' rather than of universal accessibility and support--which has led to the exclusive and tense space we are familiar with today. Several other elements to public bathrooms' contestation can continue to be explored by historians, architects, sociologists, or planners. One specific element of the public bathroom that I wish I had been able to explore is the inconsistency of the societally imposed gender binary in terms of labor within the public bathroom; it is socially acceptable to find women cleaning staff within the men's room, yet it is still considered controversial to find a trans man there. The public bathroom's control over dynamics of gender, class and race could be endlessly discussed and analyzed. Furthermore, the multitude of topics that this thesis covers could each have their own theses--I acknowledge I did not explore every subtopic in its entirety and each have complex, intricate histories of their own. Instead, I hope that this thesis can provoke thought into what our public spaces serve to accomplish, what they intend to symbolize and what their design has attempted to control or prevent.

Those that have planned and designed public bathrooms throughout history have assumed a submissive passivity from the people that will use it. Yet, people have consistently pushed against the architectural standard of public bathrooms, using it however they would like while also demanding or creating change. This autonomy has not only taken place within the walls of public bathrooms--trans and gender fluid people have created websites such as "Refuge Restrooms,"<sup>206</sup> or apps such as "Transquat,"<sup>207</sup> which allow one to search or pin their location, in turn providing the nearest public bathrooms that are safe and accessible for trans and gender

---

<sup>206</sup> *Refuge Restrooms*, <https://www.refugerestrooms.org/>.

<sup>207</sup> *Transquat*, <https://apps.apple.com/us/app/transquat/id521546602>.



non-conforming or fluid people. New Yorkers have created other such resources, such as maps indicating where all of the public (and private public) bathrooms are located across New York City (Fig. 4.3). People have also taken to sharing the private codes for opening the bathrooms at certain restaurants or cafes. The lack of safe and reliable public bathroom access in New York City has repeatedly enacted the formation and strengthening of communities within the urban public.

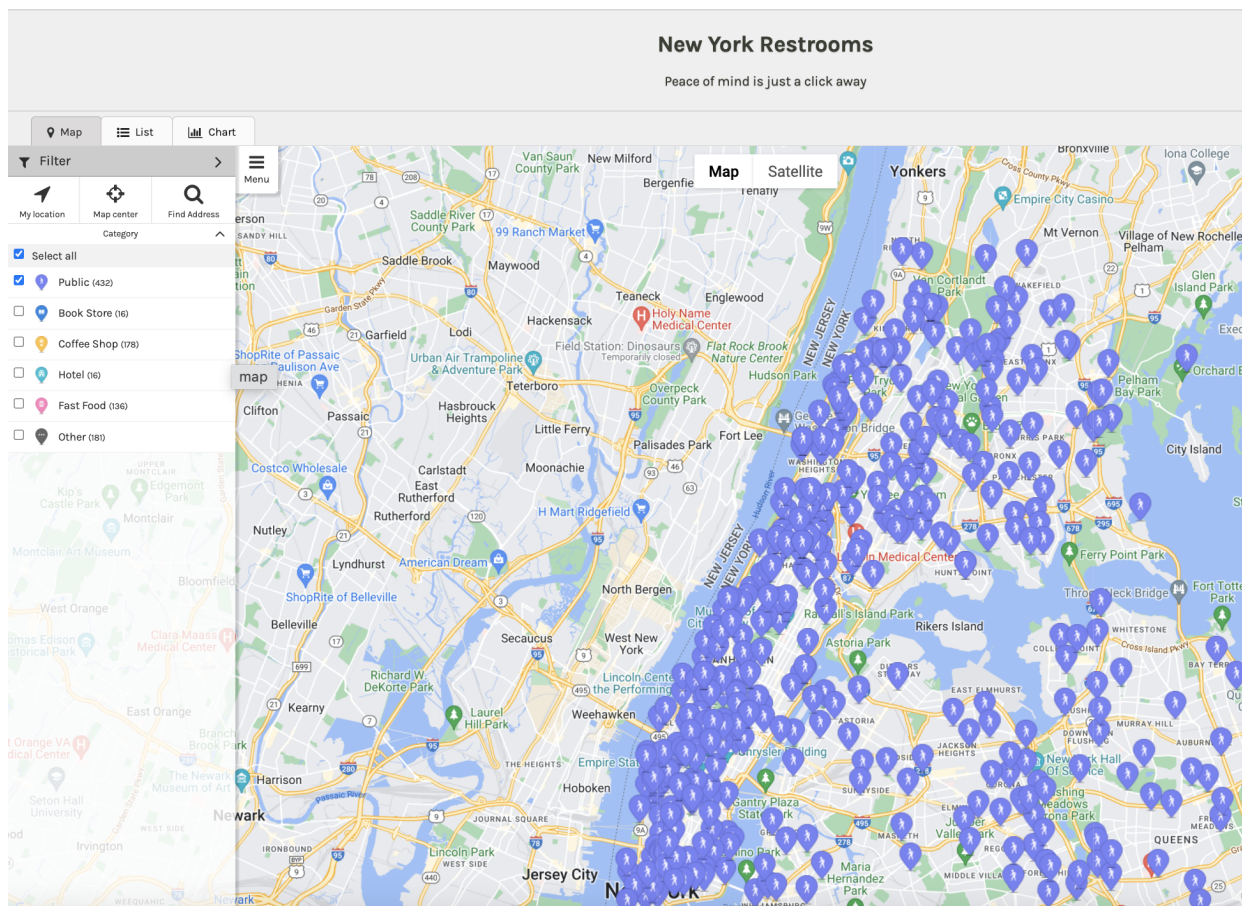

Figure 4.3: “New York Restrooms,” digital map, via: <https://m3.mappler.net/nyrestroom/>.

The frustration with cities' lack of public bathrooms has not only led to such online and digital networks. New Yorkers have also led protests in public parks and squares, rallying for more safe, clean and accessible public bathrooms across the city.<sup>208</sup> Many of these frustrations have come as a response to the NYC government's dismissal of their 20-year franchise agreement with JC Decaux, which was made in 2006 under the Bloomberg administration and which promised the installation of 20 automatic public toilets (APT) across the city.<sup>209</sup> As of 2022, only 5 of these 20 have been installed, while the rest sit in a storage warehouse in Queens.<sup>210</sup> While 20 bathrooms would never have been enough to properly accommodate the entire city, it is illuminating that New York City administrators chose not to meet such a small benchmark.

These automated public toilets are also troublesome from an architectural and sociological perspective. Made of glass and steel (some of the public bathroom's favorite materials), the APT's that the New York City administration have installed are only open from 8 a.m. to 8 p.m., and when in operation, the automatic doors only slide open after one deposits 25 cents, and after 15-minutes, the doors will automatically open, followed by "an automatic 90-second self-cleaning process" (Fig. 4.4).<sup>211</sup> The floor sensors have a minimum of 45 pounds and a maximum of 550 pounds or else the doors will simply not close.<sup>212</sup> Therefore, even though the New York City government has barely followed through with this contract--which expires in 2026--when it has, these APT's resemble the same approach to public bathrooms that New York

---

<sup>208</sup> Molly Crane-Newman, "New Yorkers demand city install safe, clean restrooms for city's 8.5 million residents," *Daily News*, August 28, 2018, <https://www.nydailynews.com/new-york/ny-new-yorkers-demand-city-install-safe-clean-restrooms-for-city-s-85-million-residents-20180828-story.html>.

<sup>209</sup> Reuven Blau, "NYC's Promised Public Bathrooms Still Doing the Waiting Dance," *The City*, March 29, 2022, <https://www.thecity.nyc/life/2022/3/29/23002372/nyc-promised-public-bathrooms-still-waiting>.

<sup>210</sup> Ibid.

<sup>211</sup> Jennifer Lee, "New Yorkers, You May Be Excused: A Pay Toilet Opens," *The New York Times*, January 10, 2008, <https://cityroom.blogs.nytimes.com/2008/01/10/a-pay-toilet-opens-no-need-to-hold-everything/>.

<sup>212</sup> Ibid.

City administrators and government officials have taken in the past, in which access is controlled depending upon your identity and behavior is regulated through design measures.



Figure 4.4: Daniel L. Doctoroff, former Deputy Mayor for Economic Development, at the opening of the first APT, photograph by Paul Burnett from *The New York Times*, 2008.

As the delay in fulfilling the promises of this contract has continued over the past 16 years, other styles of public bathrooms have been constructed. Perhaps to distract from this delay, or perhaps speaking to the sociocultural desires of the 2010's, various news outlets have begun praising certain newly renovated public bathrooms (Fig. 4.5, Fig. 4.6, Fig. 4.7, Fig. 4.8). Yet, there are trends strung between the subjects of these articles' praise that illuminate that, even with minor visual or aesthetic differences, newer public bathrooms draw from the same conclusions and beliefs that influenced their predecessors' design from centuries earlier. It is no coincidence that the public bathrooms receiving such rampant celebration are products of philanthropy. The characteristics granting these public bathrooms titles such as the best in New York City, in America, and even in the world are purely aesthetic: wallpaper was installed,

attendants returned to their entrances (where they are prohibited from accepting tips, “by park rules”<sup>213</sup>), toilet technologies are the newest on the market, fresh flowers decorate the countertops, classical music plays overhead.

**The New York Times**

## ***Is This New York City’s Nicest Public Bathroom?***

Figure 4.5: Winnie Hu’s headline for *The New York Times* in reference to the Greeley Square Park public bathroom, February 14, 2020.

ARTS & CULTURE NEW YORK NEWS

### **IS THE GREELEY SQUARE BATHROOM “AMERICA’S BEST RESTROOM”?**

Figure 4.6: Michelle Young’s headline for *Untapped Cities*, in reference to the newly renovated Greeley Square public bathroom from from 2020

NEWS

## **Bryant Park's Bathroom Ranked Best In The World!**

Figure 4.7: Jen Carlson’s headline for *gothamist*, October 3, 2011.

**CNN BUSINESS**

Markets Tech Media Success Video



## **New York's most luxurious public restroom just got a \$300,000 makeover**

Figure 4.8: Jackie Wattle’s headline for *CNN Business*, in reference to Bryant Park public bathrooms, April 28, 2017.

<sup>213</sup> Associated Press, “This might be the fanciest public bathroom in NYC,” *New York Post*, April 27, 2017, <https://nypost.com/2017/04/27/this-might-be-the-fanciest-public-bathroom-in-nyc/>.

The Bryant Park public bathroom was renovated as a response to the complaints of philanthropist Brook Astor, who the New York Times referred to as “the great dame of New York society.”<sup>214</sup> In 1979, Astor was on her way to the New York Public Library where she claimed a “hooligan approached her...and tried to sell her drugs,” following which she told “her friend David Rockefeller that the area needed to be cleaned up” and thus the two began their vision of that process--which constituted the renovation of the park’s public bathroom.<sup>215</sup> From this narrative, it is made clear again that public bathrooms are not about universal support or care--they are about the materialization of certain sociocultural beliefs. The story behind the Bryant Park’s public bathrooms’ renovation is reminiscent of the ‘protectionist’ beliefs of the late 19th and early 20th century, which sought to protect the white upper class, especially women, from anybody that fell outside of this demographic. While Bryant Park’s public bathrooms are supposed to be public, their operational hours being from 10 a.m to 10 p.m and the stationing of an (underpaid) attendant out front illustrate how the public bathroom continues to be a site of implicit social control and regulation.

News platforms commonly celebrate The Bryant Park renovations without any consideration of their context. This context references themes that have associated public bathroom construction throughout history: the prioritization of the comfortability and perspective of the white upper class, and the regulation of access and behaviors rather than their accommodation and acceptance. The history behind the Bryant Park renovations represent how comfort and safety are benefits attained through political and social power and status. Beyond indicating that the state of feeling unsafe is only legible when coming from a wealthy, white

---

<sup>214</sup> Winnie Hu, “A Public Restroom Fit for Brooke Astor Gets an Upgrade,” *The New York Times*, April 5, 2017, <https://www.nytimes.com/2017/04/05/nyregion/bryant-park-restroom-renovation.html#:~:text=Designed%20as%20a%20public%20comfort,plasterboard%20covered%20the%20bathroom%20floor..>

<sup>215</sup> Ibid.

person with connections, the Bryant Park renovations also illustrate how architects believe ‘safety’ should be designed in this context.

The referenced headlines demonstrate what public bathrooms need to do to get attention; if they are pretty, with shiny new amenities, and a long wait that proves their worth, then they are no longer too embarrassing or discomforting to be discussed. But, these public bathrooms at Bryant Park and Greeley Square Park have not done anything to solve the crisis of public bathroom shortages in New York City. They are not models that architects or planners can easily repeat, being hundreds of thousands of dollars to maintain annually. They also do not respond to the various controversies that people have voiced regarding public bathrooms since 1869, in terms of accessibility, gender and class. Instead, they exemplify that public bathrooms are only appreciated or celebrated if they cater to the aesthetics of wealth and luxury. Otherwise, they stay in storage warehouses, or remain out of order indefinitely.

This new wave of public bathroom’s philanthropic aesthetics has coincided with New York City’s recent decision that changes in Building Code do not permit the enforcement of restaurants to make their bathrooms accessible, open and free to the public.<sup>216</sup> It is unclear why this decision would be made. It is unclear why New York City administrators are treating public bathrooms as luxuries that one must earn, especially considering how they were initially deemed inseparable from the overall well-being of the city.

This thesis was unable to cover the impact that the COVID-19 pandemic has had on the public bathroom in New York City. In response to “COVID-19 safety protocols,” the public bathrooms in subway stations, public parks, and public libraries were closed in 2020, and it is

---

<sup>216</sup> Aaron Elstein, “City won’t force restaurants to open restrooms to the public,” *Crain’s New York Business*, March 21, 2022, [https://www.crainsnewyork.com/hospitality-tourism/new-york-city-wont-force-restaurants-open-restrooms-public?adobe\\_mc=MCMID%3D81787808265607223230753288998905790469%7CMCORGID%3D138EFF2554E6E7220A4C98C6%2540AdobeOrg%7CTS%3D1648585161&CSAuthResp=1%3A%3A670267%3A23%3A24%3Asuccess%3A683B07779FBE5E624BB0E1CDCE4EA4CE](https://www.crainsnewyork.com/hospitality-tourism/new-york-city-wont-force-restaurants-open-restrooms-public?adobe_mc=MCMID%3D81787808265607223230753288998905790469%7CMCORGID%3D138EFF2554E6E7220A4C98C6%2540AdobeOrg%7CTS%3D1648585161&CSAuthResp=1%3A%3A670267%3A23%3A24%3Asuccess%3A683B07779FBE5E624BB0E1CDCE4EA4CE).



unclear how many, and which, have since been reopened.<sup>217</sup> As of this past September, 76 public bathrooms in subway stations were still closed, which the MTA has explained is due to transit leaders diverting cleaning staff to “daily scrub trains, buses, and stations instead,” indicating how New York City administrators and officials continue to regard public bathrooms as a small priority relative to others.<sup>218</sup> On the other hand, the COVID-19 pandemic has intensified the “ick factor”--as it has been called--that many people have towards the proximity to others’ bodies and waste within public bathrooms.<sup>219</sup> The hesitation, anxiety and panic that has been expressed around visiting public bathrooms throughout the ongoing COVID-19 pandemic has illustrated how the same fears that led to public bathrooms initiation have now led, in many cases, to their closure. More broadly, the anxieties and stigmas around contagion and illness that COVID-19 has instituted, and the sociological dynamics and tensions that they have enacted, are strikingly similar to those recounted from New York City’s first encounters with epidemics during the 19th century. While public bathrooms were initially deemed a strategy for keeping New York City’s streets, and consequently those that worked and lived among them, in a better physical and ‘moral’ condition, today, people have characterized them as a threat to their safety and comfort.

As I was in the process of concluding this thesis, New York City Council Member, Rita Joseph, and Manhattan Borough President, Mark Levine, introduced a bill to the New York City Council that aims to construct at least one public bathroom in every zip code in the city, which would be self-cleaning and “open around the clock and year round.”<sup>220</sup> This bill would require

---

<sup>217</sup> Valeria Ricciulli, “New York Needs a Place to Pee in Public *So Bad*,” *Curbed*, December 3, 2020, <https://www.curbed.com/2020/12/nyc-public-bathrooms-locations-problem.html>.

<sup>218</sup> Kevin Duggan, “Nowhere to go: MTA’s Daily COVID cleaning regimen is keeping station restrooms shuttered,” *amNY*, September 16, 2021, <https://www.amny.com/transit/mta-covid-cleaning-regimen-is-keeping-station-restrooms-closed/>.

<sup>219</sup> Steve Calechman, “How risky is using a public bathroom during the pandemic?” *Harvard Health Publishing: Harvard Medical School*, August 24, 2020, <https://www.health.harvard.edu/blog/how-risky-is-using-a-public-bathroom-during-the-pandemic-2020071420556>.

<sup>220</sup> Dean Moses, “EXCLUSIVE: Let our people go! City Council bill seeks relief to reopen more public bathrooms

the Department of Transportation and the Department of Parks and Recreation “to consult with local community boards and the public regarding...new bathroom locations and publish a report on feasible locations” no later than June 2023.<sup>221</sup> Bills, proposals, and efforts of this kind should be celebrated, but they must also be contextualized by and explored alongside the history of public bathroom construction, design and enforcement in New York City, to ensure that a genuine prioritization of access and support for all is replacing that of social regulation and exclusion.

This thesis can be seen as a statement on how public spaces can impact social dynamics and social culture as a result of the intentions of those behind their development, funding and construction. Architecture is never neutral, and it is never stagnant. When we look at, experience or interact with public spaces, and notice how we feel or act in response, we gain insight into what the administrators, governments, and architects behind them wanted us to learn and what actions or ideals they wanted us to comply with. Further, though architecture appears to be solid and immutable, we must remember how disabled, queer and trans people have continuously demonstrated that the opposite is true. We can influence how pieces of the built environment attempt to shape or control how we move and act--either in how we choose to behave or conduct ourselves with them, or through working with designers, architects, planners and administrators to change them. The history that this thesis covers has demonstrated that both work.

---

across New York City,” *amNY*, April 28, 2022,  
<https://www.amny.com/news/exclusive-city-council-bill-more-public-bathrooms-new-york-city/>.

<sup>221</sup> Ibid.



## Works Cited

- A Dictionary of Modern Architecture: University of Chicago. "Deutscher Werkbund." November 16, 2015.  
<https://voices.uchicago.edu/201504arth15709-01a2/2015/11/16/deutscher-werkbund/>.
- Abadi Accessibility. "ANSI vs. ADA." January 4, 2016. <http://abadiaccess.com/ansi-vs-ada/>.
- ADA Standards for Accessible Design. "Codes of Federal Regulations." 1991.  
<https://www.ada.gov/1991standards/adastd94-archive.pdf>.
- American Restroom Association. "About Us." <https://americanrestroom.org/about-us/>.
- Associated Press. "This might be the fanciest public bathroom in NYC." *New York Post*. April 27, 2017.  
<https://nypost.com/2017/04/27/this-might-be-the-fanciest-public-bathroom-in-nyc/>.
- Baldwin, Peter. "Public Privacy: Restrooms in American Cities, 1869-1932." *Journal of Social History* 48 no. 2 (2014): 264-288. <https://www.jstor.org/stable/43306014>.
- Barcan, Ruth. "Dirty Spaces: Separation, Concealment and Shame in the Public Toilet." In *Toilet: Public Restrooms and the Politics of Sharing*, edited by Harvey Molotch and Laura Norén, 25-41. New York: New York University Press, 2010.
- Barnett, Brian, Ariana E. Nesbit and Renée M. Sorrentino. "The Transgender Bathroom Debate at the Intersection of Politics, Law, Ethics, and Science." *Journal of the American Academy of Psychiatry and the Law Online* 46 no. 2 (2018): 232-241. <http://jaapl.org/content/jaapl/46/2/232.full.pdf>.
- Beauchamp, Toby. *Going Stealth: Transgender Politics and U.S. Surveillance Practices*. Durham: Duke University Press, 2019.
- Bever, Lindsey. "A plan to keep drug users from shooting up in public restrooms — and why it may be a bad idea." *The Washington Post*. June 29, 2018.  
<https://www.washingtonpost.com/news/to-your-health/wp/2018/06/29/the-plan-to-keep-drug-users-from-shooting-up-in-public-restrooms-and-why-it-may-be-a-bad-idea/>.
- Blau, Reuven. "NYC's Promised Public Bathrooms Still Doing the Waiting Dance." *The City*. March 29, 2022.  
<https://www.thecity.nyc/life/2022/3/29/23002372/nyc-promised-public-bathrooms-still-waiting>.
- Boris, Eileen. "'You Wouldn't Want One Of 'Em Dancing With Your Wife': Racialized Bodies on the Job in World War II." *American Quarterly* 50 no. 1 (1998). <https://muse.jhu.edu/article/175687>.

- Burgess, Rebekah and Mariana Mogilevich. "Cataloging Comfort." *Urban Omnibus*. May 2, 2018, <https://urbanomnibus.net/2018/05/cataloging-comfort/#:~:text=In%20the%201930s%2C%20when%20Robert.access%20to%20the%20public%20realm>.
- Cahill, Spencer et. al. "Meanwhile Backstage: Behavior in Public Bathrooms." *Urban Life* 14, no. 1 (1985): 33-58. <http://www.csun.edu/~tph53095/Meanwhile%20Backstage%20Reading.pdf>.
- Calechman, Steve. "How risky is using a public bathroom during the pandemic?" *Harvard Health Publishing: Harvard Medical School*. August 24, 2020. <https://www.health.harvard.edu/blog/how-risky-is-using-a-public-bathroom-during-the-pandemic-2020071420556>.
- Chauncey, George. *Gay New York: Gender, Urban Culture, and the Making of the Gay Male World, 1890-1940*. New York: BasicBooks, 1994.
- Chou, Julie, Kevin A. Gurley and Boyeong Hong. "The Need for Public Bathrooms in New York City." *Urban Design Forum*. July 24, 2020. <https://urbandesignforum.org/proposals/the-need-for-public-bathrooms-in-new-york-city/>.
- Colquhoun, Alan. *Modern Architecture*. Oxford: Oxford University Press, 2002.
- Congress for the New Urbanism. "Is Public Architecture Dysfunctional?" October 23, 2020. <https://www.cnu.org/publicsquare/2020/10/23/public-architecture-dysfunctional>.
- Crane-Newman, Molly. "New Yorkers demand city install safe, clean restrooms for city's 8.5 million residents." *Daily News*. August 28, 2018. <https://www.nydailynews.com/new-york/ny-new-yorkers-demand-city-install-safe-clean-restrooms-for-city-S-85-million-residents-20180828-story.html>.
- Davis, Alexander. *Bathroom Battlegrounds: How Public Restrooms Shape the Gender Order*. Oakland: University of California Press, 2020.
- De Tocqueville, Alexis. *Democracy in America* vol.4. London: Saunders and Otley, 1840.
- Dehbozorgi, Mohsen. Recognition of the Elements of Power in Architecture. *Urban and Regional Planning* 1 no. 4 (2016): 97-104.
- Dictionary.com. "Comfort Station." <https://www.dictionary.com/browse/comfort-station>.
- Duggan, Kevin. "Nowhere to go: MTA's Daily COVID cleaning regimen is keeping station restrooms shuttered."

amNY. September 16, 2021.

<https://www.amny.com/transit/mta-covid-cleaning-regimen-is-keeping-station-restrooms-closed/>.

Elstein, Aaron. "City won't force restaurants to open restrooms to the public." *Crain's New York Business*. March 21, 2022.

[https://www.crainsnewyork.com/hospitality-tourism/new-york-city-wont-force-restaurants-open-restrooms-public?adobe\\_mc=MCMID%3D81787808265607223230753288998905790469%7CMCORGID%3D138FF2554E6E7220A4C98C6%2540AdobeOrg%7CTS%3D1648585161&CSAuthResp=1%3A%3A670267%3A23%3A24%3Asuccess%3A683B07779FBE5E624BB0E1CDCE4EA4CE](https://www.crainsnewyork.com/hospitality-tourism/new-york-city-wont-force-restaurants-open-restrooms-public?adobe_mc=MCMID%3D81787808265607223230753288998905790469%7CMCORGID%3D138FF2554E6E7220A4C98C6%2540AdobeOrg%7CTS%3D1648585161&CSAuthResp=1%3A%3A670267%3A23%3A24%3Asuccess%3A683B07779FBE5E624BB0E1CDCE4EA4CE).

Emmons, Paul and Andreea Mihalache. "Architectural handbooks and the user experience." In *Use Matters: an alternative history of architecture*, edited by Kenny Cupers, 36-50. New York: Routledge, 2013.

Federal Register The Daily Journal of the United States Government. "Design and Construction Requirements; Compliance With ANSI A117.1 Standards." October 24, 2008.

<https://www.federalregister.gov/documents/2008/10/24/E8-23785/design-and-construction-requirements-compliance-with-ansi-a1171-standards>.

Frank, Gillian. "The Anti-Trans Bathroom Nightmare Has Its Roots in Racial Segregation." *Slate*. November 10, 2015.

<https://slate.com/human-interest/2015/11/anti-trans-bathroom-propaganda-has-roots-in-racial-segregation.html>.

Fraser, Nancy. "Rethinking the Public Sphere: A Contribution to the Critique of Actually Existing Democracy."

*Social Text* 25/26 (1990): 56-80. <https://www.jstor.org/stable/466240>.

Goldberger, Paul. "Robert Moses, Master Builder, is Dead at 92." *The New York Times*. July 30, 1981.

<https://www.nytimes.com/1981/07/30/obituaries/robert-moses-master-builder-is-dead-at-92.html#:~:text=Moses%2C%20whose%20long%20list%20of,was%20given%20as%20heart%20failure>.

Habermas, Jürgen. *The Structural Transformation of the Public Sphere*. Cambridge: The MIT Press, 1989.

Hamraie, Aimi. *Building Access: Universal Design and the Politics of Disability*. Minneapolis: University of Minnesota Press, 2017.

Hamraie, Aimi. "Designing Collective Access: A feminist disability theory of universal design." In *Disability, Space, Architecture, A Reader*, edited by Jos Boys, 78-87. New York: Routledge, 2017.

Historia Sanitaria. "1866 - The Metropolitan Health Act was passed in New York."

<https://www.wiki.sanitarc.si/1866-metropolitan-health-act-passed-new-york-efforts-dr-stephen-smith-dorm-an-eaton-giving-adequate-power-health-authority-enforce-public-health-laws/>.

Horan, Julie. *The Porcelain God*. Secaucus: Carol Publishing Group, 1997.

Hu, Winnie. "A Public Restroom Fit for Brooke Astor Gets an Upgrade." *The New York Times*. April 5, 2017.

<https://www.nytimes.com/2017/04/05/nyregion/bryant-park-restroom-renovation.html#:~:text=Designed%20as%20a%20public%20comfort,plasterboard%20covered%20the%20bathroom%20floor.>

Imrie, Rob. "The body, disability, and Le Corbusier's Conception of the Radiant Environment." In *Disability, Space, Architecture: A Reader*, edited by Jos Boys, 22-31. New York: Routledge, 2017.

International Code Council. "Overview."

[https://www.iccsafe.org/about/overview-2/#:~:text=The%20International%20Code%20Council%20\(ICC,an,d%20Code%20Administrators%20International%2C%20Inc.](https://www.iccsafe.org/about/overview-2/#:~:text=The%20International%20Code%20Council%20(ICC,an,d%20Code%20Administrators%20International%2C%20Inc.)

International Code Council Digital Codes. "Section 603 Toilet and Bathing Rooms."

<https://codes.iccsafe.org/content/ICCA11712017P2/chapter-6-plumbing-elements-and-facilities.>

Jenkins, Stephanie. "Constructing Ableism." *Genealogy* 5 no. 66 (2021): 1-15.

<https://doi.org/10.3390/genealogy5030066.>

Jennings, Jan. "Le Corbusier's 'Naked': 'Absolute Honesty' and (Exhibitionist) Display in Bathroom Settings."

*Interiors* 2, no. 3 (2011): 307-331.

[https://intypes.cornell.edu/uploads/research/64/LeCorbusier's%20Naked\\_Article.pdf.](https://intypes.cornell.edu/uploads/research/64/LeCorbusier's%20Naked_Article.pdf.)

Joukowsky Institute for Archaeology & the Ancient World. "Internalized Authority and the Prison of the Mind:

Bentham and Foucault's Panopticon."

[https://www.brown.edu/Departments/Joukowsky\\_Institute/courses/13things/7121.html.](https://www.brown.edu/Departments/Joukowsky_Institute/courses/13things/7121.html.)

Le Corbusier. *The Decorative Art of Today*. Cambridge: MIT Press, 1987.

Lee, Jennifer. "New Yorkers, You May Be Excused: A Pay Toilet Opens." *The New York Times*. January 10, 2008.

<https://cityroom.blogs.nytimes.com/2008/01/10/a-pay-toilet-opens-no-need-to-hold-everything/>.

Lescaze, William. "The Meaning of Modern Architecture." *The North American Review* 244, no. 1 (1937):

110-120. <https://www.jstor.org/stable/25114911.>

Lupton, Ellen. *The Bathroom, the Kitchen, and the Aesthetics of Waste*. New York: Princeton Architectural

- Press, 1992.
- Mayerson, Arlene. "The History of the Americans with Disabilities Act A Movement Perspective." *Disability Rights Education & Defense Fund*. 1992.  
<https://dredf.org/about-us/publications/the-history-of-the-ada/#:~:text=On%20May%209%2C%201989%20Senators,multi%2Dlayered%20strategy%20for%20passage.>
- Melosi, Martin. *The Sanitary City Urban Infrastructure in America from Colonial Times to the Present*. Baltimore: The Johns Hopkins University Press, 2000.
- Merriam-Webster. "Bathroom." <https://www.merriam-webster.com/thesaurus/bathroom>.
- Merriam-Webster. "Restroom." <https://www.merriam-webster.com/thesaurus/restroom>.
- Moses, Dean. "EXCLUSIVE: Let our people go! City Council bill seeks relief to reopen more public bathrooms across New York City." *amNY*. April 28, 2022.  
<https://www.amny.com/news/exclusive-city-council-bill-more-public-bathrooms-new-york-city/>.
- National Center for Biotechnology Information. "New York City's Water Supply System: Past, Present, and Future." <https://www.ncbi.nlm.nih.gov/books/NBK566285/>.
- Neufert, Ernst. *Architects' Data*, edited by Rudolf Herz and translated by G.H. Berger, et al. Hamden: Archon Books, 1970.
- Nestle, Joan. *A Restricted Country*. Ithaca: Firebrand Books, 1987.
- New York Association for Improving the Condition of the Poor. *Comfort Stations in New York City: A Social, Sanitary and Economic Survey* no. 80 (1914).
- New York City Comptroller Brad Lander. "Discomfort Stations: The Conditions and Availability of NYC Parks Bathrooms." June 27, 2019.  
<https://comptroller.nyc.gov/reports/discomfort-stations-the-conditions-and-availability-of-nyc-parks-bathrooms/>.
- Nolan, Liam. *From the Church of Disco to Waterfront Ruins: An Analysis of Gay Space*. BA Thesis: Bard College, 2019.
- Oxford English Dictionary. "Bathroom." <https://www.oed.com/view/Entry/16165?redirectedFrom=bathroom#eid>.
- Oxford English Dictionary. "Restroom." <https://www.oed.com/view/Entry/275516?redirectedFrom=restroom#eid>.

- Penner, Barbara, "Entangled with a User: Inside Bathrooms with Alexander Kira and Peter Greenaway." In *Toilet: Public Restrooms and the Politics of Sharing*, edited by Harvey Molotch and Laura Norén, 229-252. New York: New York University Press, 2010.
- Public Water. "Privatization, Part II: Hamilton, Burr, and the Manhattan Company." <http://public-water.com/story-of-nyc-water/privatization-ii/>.
- Refuge Restrooms. <https://www.refugerestrooms.org/>.
- Renner, Andrea. "A Nation that Bathes Together: New York City's Progressive Era Public Baths." *Journal of the Society of Architectural Historians* 67, no. 4 (2008): 504-531. <https://www.jstor.org/stable/10.1525/jsah.2008.67.4.504>.
- Ricciulli, Valeria. "New York Needs a Place to Pee in Public *So Bad*." *Curbed*. December 3, 2020. <https://www.curbed.com/2020/12/nyc-public-bathrooms-locations-problem.html>.
- Robertson, Lance. "Celebrating 50 Years of the Architectural Barriers Act." *Administration for Community Living*. September 7, 2018. <https://acl.gov/news-and-events/acl-blog/celebrating-50-years-architectural-barriers-act>.
- Sanders, Joel and Susan Stryker. "Stalled: Gender-Neutral Public Bathrooms." *The South Atlantic Quarterly* 115:4 (2016): 779-788.
- Serlin, David. "Pissing Without Pity: Disability, Gender and the Public Toilet." In *Toilet: Public Restrooms and the Politics of Sharing*, edited by Harvey Molotch and Laura Norén, 167-185. New York: New York University Press, 2010.
- Schilt, Kristen and Laurel Westbrook. "Bathroom Battlegrounds and Penis Panics." *Contexts* 14 no.3 (2015): 26-31. <https://journals.sagepub.com/doi/pdf/10.1177/1536504215596943>.
- Schwartz, Joel. "Robert Moses and City Planning." In *Robert Moses and the Modern City*, edited Hilary Ballon and Kenneth T. Jackson, 130-133. New York: W.W Norton & Company, 2007.
- Shah, Rajiv C. and Jay P. Kesan. "How Architecture Regulates." *Journal of Architectural and Planning Research* 24, no. 4 (2007): 350-359. <https://www.jstor.org/stable/4303081>.
- SNAC Cooperative. "New York Association for Improving the Condition of the Poor. Office of the Corresponding Secretary and General Agent." <https://snaccooperative.org/view/32319533>.

Stalled! <https://www.stalled.online/>.

Sturges, W. Knight. "Cast Iron in New York." *The Architectural Review* 114 (October 1953): 232-237.

The Mayor's Committee of New York City. *Report on Public Baths and Public Comfort Stations by the Mayor's Committee of New York City* (1897).

Tierney, John. "The Big City; In 80's, Fear Spread Faster Than AIDS." *New York Times*. June 15, 2001.

<https://www.nytimes.com/2001/06/15/nyregion/the-big-city-in-80-s-fear-spread-faster-than-aids.html>

Trans Hub. "What Does Cis Mean?" <https://www.transhub.org.au/101/cis>.

Transquat. <https://apps.apple.com/us/app/transquat/id521546602>.

U.S. Access Board Advancing Full Access and Inclusion For All. "History of the U.S. Access Board."

<https://www.access-board.gov/about/history.html#:~:text=1973%20%E2%80%93%20The%20Access%20Board%20is%20Created&text=A%20provision%20in%20the%20law.and%20Transportation%20Barriers%20Compliance%20Board>.

Visual Arts Cork. "Deutscher Werkbund (1907-1933)."

<http://www.visual-arts-cork.com/architecture/deutscher-werkbund.htm>.

Wagner Collaborative Metal Works. "Should I Still Be Concerned About ICC A117.1?"

<https://wagnercompanies.com/ansi-a117/#:~:text=With%20the%20merging%20of%20the.version%20is%20the%202009%20edition>.

Waterworks History. "Documentary History of American Water-Works."

[http://www.waterworkshistory.us/NY/New\\_York\\_City/manhattan.htm](http://www.waterworkshistory.us/NY/New_York_City/manhattan.htm).

Whole Buildings Design Guide. "History of Accessible Facility Design." Last updated July 18, 2019.

<https://www.wbdg.org/design-objectives/accessible/history-accessible-facility-design#:~:text=The%20first%20nationally%20recognized%20accessible.the%20Easter%20Seals%20Research%20Foundation>.

Wigley, Mark. "Chronic Whiteness." *Sick Architecture*, e-flux Architecture (November 2020).

<https://www.e-flux.com/architecture/sick-architecture/360099/chronic-whiteness/>.

Williams, Marilyn. *Washing "The Great Unwashed": Public Baths in Urban American, 1840-1920*. Columbus: The Ohio State University Press, 1991.

Wilson, Mabel. "Black Bodies / White Cities: Le Corbusier in Harlem." *ANY: Architecture New York* no. 16 (1996): 35-39. <https://www.jstor.org/stable/41796597>.

# List of Figures

## Chapter 1

Figure 1.1: “Reservoir of Manhattan Water Works *Chambers St. 1825.*” From *Manual of the Corporation of the City of New York.*

<https://nypl.getarchive.net/media/reservoir-of-manhattan-water-works-chambers-st-1825-dfa752>.

Figure 1.2: “Map 1, The Public Baths of Manhattan, 1915.” From *Washing “The Great Unwashed”: Public Baths in Urban America 1840-1920*, 63.

Figure 1.3: J.C. Cady & Co. “People’s Bath No. I.” Section drawing. From “A Nation that Bathes Together: New York City’s Progressive Era Public Baths,” 511.

Figure 1.4: Brunner & Tryon Architects. “The Baron De Hirsch Rain Baths.” Site plan of men’s section on basement floor. From *American Plumbing Practice*. New York: The Engineering Record (1896), 200.

Figure 1.5: Brunner & Tryon Architects. “The Baron De Hirsch Rain Baths.” Site plan of women’s section on first floor. From *American Plumbing Practice*. New York: The Engineering Record (1896), 201.

Figure 1.6: J.C. Cady & Co. “People’s Baths.” Photograph. From “A Nation that Bathes Together: New York City’s Progressive Era Public Baths,” 511.

Figure 1.7: Werner & Windolph. “West 60th Street Baths.” Photograph. From “A Nation that Bathes Together: New York City’s Progressive Era Public Baths,” 518.

Figure 1.8: Ladies,’ ‘Men,’ and ‘Colored’ entrances to public bathroom. Photograph. From *Getty Images*.  
<https://www.gettyimages.com.au/photos/segregation>.

## Chapter 2

Figure 2.1: “No Sign! What Is It? Male Or Female?” Photograph. From *Comfort Stations in New York City: A Social, Sanitary and Economic Survey*, 12.

Figure 2.2: “AN INADEQUATE SIGN. Not visible a few feet to either side of the stairway.” Photograph. From *Comfort Stations in New York City: A Social, Sanitary and Economic Survey*, 12.

Figure 2.3: Frank Lloyd Wright. Elevation of Larkin Building’s 2nd Floor Toilet Room. From Avery Architectural and Fine Arts Library, Columbia University. <https://library.artstor.org/asset/28483471>.

Figure 2.4: Ernst Neufert. “Universal Standard” and “Relative proportions.” From *Architects’ Data*, 14.



Figure 2.5: Ernst Neufert. “Bathrooms.” From *Architects’ Data*, 132.

Figure 2.6: Department of Parks NYC. “Prospect Park Comfort Station.” From *Comfort Stations Survey of 1934*, 71.

Figure 2.7: Department of Parks NYC. “Central Park Comfort Station.” From *Comfort Stations Survey of 1934*, 9.

Figure 2.8: Department of Parks NYC. “Union Square Comfort Station.” *Comfort Station Survey of 1934*, 34.

Figure 2.9: Department of Parks NYC. “Union Square Comfort Station.” *Comfort Station Survey of 1934*, 34.

Figure 2.10: Department of Parks NYC. “Union Square Comfort Station.” *Comfort Station Survey of 1934*, 34.

Figure 2.11: Department of Parks NYC. “Type C, men’s door side elevation.” Accessed via NYC Parks Archives.

Figure 2.12: Department of Parks NYC. “Basement floor and ground floor plans.” Accessed via NYC Parks Archives.

Figure 2.13: Department of Parks NYC. “Type N, front and right side elevations.” Accessed via NYC Parks Archives.

Figure 2.14: Department of Parks NYC. “Type N, floor plan ‘scheme 2’.” Accessed via NYC Parks Archives.

Figure 2.15: Department of Parks NYC. “Type N, floor plan ‘scheme 1.’” Accessed via NYC Parks Archives.

Figure 2.16: Department of Parks NYC. “Type C, roof plan.” Accessed via NYC Parks Archives.

Figure 2.17: Department of Parks NYC. “Type N, front elevation.” Accessed via NYC Parks Archives.

Figure 2.18: Department of Parks NYC. “Red Hook Park Comfort Station.” *Comfort Station Survey of 1934*, 95.

Figure 2.19: Department of Parks NYC. “Fort Four Comfort Station.” *Comfort Stations Survey of 1934*, 129.

### **Chapter 3**

Figure 3.1: Department of Justice. “4.17 Toilet Stalls.” From *ADA Standards for Accessible Design*.  
<https://www.ada.gov/1991standards/adastd94-archive.pdf>, 534.

Figure 3.2: International Code Council. “604.7.1 (A), Grab Bars with Dispenser Below.” From  
<https://codes.iccsafe.org/content/icca117-12017/chapter-6-plumbing-elements-and-facilities>.

Figure 3.3: Department of Justice. “4.17.6 Grab Bars.” From *ADA Standards for Accessible Design*.  
<https://www.ada.gov/1991standards/adastd94-archive.pdf>, 534.

Figure 3.4: Harbor City Supply. “Individual Toilet Room with Baby Changing Station.” From *Small or Single Public Restrooms*. <https://www.harborcitysupply.com/blog/small-or-single-public-restrooms-ada-guidelines/>.

Figure 3.5: Drawings of “anthropometric figures representing disability” in *Architectural Graphic Standards*. From Aimi Hamraie’s *Building Access: Universal Design and the Politics of Disability*, 32.

Figure 3.6: Drawings of “anthropometric figures, such as Joe and Josephine,” in *Architectural Graphic Standards*. From Aimi Hamraie’s *Building Access: Universal Design and the Politics of Disability*, 31.

Figure 3.7: Stalled! “Multi-User Solution.” From <https://www.stalled.online/approaches>.

Figure 3.8: Row of urinals in a public bathroom. Photograph by Mark Hamel. From <https://fineartamerica.com/featured/a-row-of-urinals-in-a-public-bathroom-mark-hamel.html>.

## Epilogue

Figure 4.1: Urban Design Forum. “Map of public bathrooms in New York City.” From <https://urbandesignforum.org/the-need-for-public-bathrooms-in-new-york-city/>.

Figure 4.2: “Waste basket within a public bathroom in New York City displays two visuals.” Image taken by author.

Figure 4.3: New York Restrooms. “Digital map.” From <https://m3.mappler.net/nyrestroom/>.

Figure 4.4: *The New York Times*. “Daniel L. Doctoroff, former Deputy Mayor for Economic Development, at the opening of the first APT.” Photograph by Paul Burnett. From <https://cityroom.blogs.nytimes.com/2008/01/10/a-pay-toilet-opens-no-need-to-hold-everything/>.

Figure 4.5: *The New York Times*. Headline in reference to Greeley Square Park Public Bathrooms by Winnie Hu. From <https://www.nytimes.com/2020/02/14/nyregion/public-bathroom-Greeley-Square.html>.

Figure 4.6: *Untapped Cities*. Headline in reference to Greeley Square Park Public Bathrooms by Michelle Young. From <https://untappedcities.com/2020/09/29/greeley-square-bathroom-americas-best-restroom/>.

Figure 4.7: *Gothamist*. Headline in reference to Bryant Park Public Bathrooms by Jen Carlson. From <https://gothamist.com/news/bryant-parks-bathroom-ranked-best-in-the-world>.

Figure 4.8: *CNN Business*. Headline in reference to Bryant Park Public Bathrooms by Jackie Wattle. From <https://money.cnn.com/2017/04/28/luxury/new-york-city-bryant-park-public-restroom/index.html>.