

Over the Water: Paul Ramírez Jonas



Over the Water:
Paul Ramírez Jonas



Over the Water: Paul Ramírez Jonas

This catalogue was published to accompany *Over the Water: Paul Ramirez Jonas*, on view at the Exploratorium, San Francisco, between Piers 15 and 17, from June 19, 2014 to January, 2015.

Editors:

Leigh Markopoulos
Marina McDougall

Publication Manager:

Leigh Markopoulos

Design:

John Borruso

Printer:

Solstice Press, Oakland

This publication is available for free download: <http://www.exploratorium.edu/arts/over-the-water>

© 2014, the authors, Paul Ramirez Jonas, Exploratorium, Pier 15, San Francisco, CA 94111, and copyright holders as listed. No part of this publication may be reproduced in any manner without permission.

All images © Exploratorium, photographers Amy Snyder and Gayle Laird, unless otherwise noted

p 13 photo Meghan McInnis, Courtesy of Creative Time

pp 14–16, 32–35, 38 (top left), and 54 courtesy of the artist and Koenig & Clinton, New York

pp 34–35 illustration from A.G. Ford, *Handling and Storage for Cargo*, (Pennsylvania, PA: International Textbook Co, 1942).

pp 47–48 photo Jose Andres Ramirez, courtesy of the artist and Koenig & Clinton, New York

p 58 photo Edwin Levick, courtesy of National Geographic Creative

pp 60–61 courtesy of San Francisco History Center, San Francisco Public Library

pp 62–63 © Brocken Inaglory

p 64 © and courtesy of Michael Flecker, Maritime Explorations

p 65 courtesy of Queensland Museum Network, Australia

p 66 © Bartek.cieslak at pl.wikipedia

p 67 photo Dr. James P. McVey, courtesy of NOAA's Small World image collection

The arts at the Exploratorium are generously funded in part by grants from the National Endowment for the Arts and the San Francisco Hotel Tax Fund.



ISBN: 978-0-943451-75-6

exploratorium®

Exploratorium

Pier 15

San Francisco, CA 94111

www.exploratorium.edu

CONTENTS

- 6 OVER THE WATER
PAUL RAMÍREZ JONAS: WE MAKE THE TREASURE
Robert Semper
- 8 ACKNOWLEDGEMENTS
Marina McDougall
- 11 CIVIL SOCIETY BY WAY OF KEYS, COINS, AND EVERYDAY LIFE:
PUBLIC ARTWORKS BY PAUL RAMÍREZ JONAS
Nato Thompson
- 25 PUBLIC TREASURE
Shannon Jackson
- 32 WE MAKE THE TREASURE
Paul Ramírez Jonas
- 42 PAUL RAMÍREZ JONAS IN CONVERSATION WITH HUGH MCDONALD
- 58 WE MAKE THE TREASURE: THEMES AND REFERENCES
Marina McDougall
- 71 Paul Ramírez Jonas Biography
- 72 Project Team

OVER THE WATER PAUL RAMÍREZ JONAS: WE MAKE THE TREASURE

Robert Semper

Last year the Exploratorium inaugurated *Over the Water*, an innovative site-specific public art program, to celebrate its new location at Piers 15 and 17, on the edge of the San Francisco Bay.

Our first project in the series was Fujiko Nakaya's ephemeral *Fog Bridge*—a large scale, interactive sculpture that spans a pedestrian bridge shrouding visitors in vaporous fog and setting the precedent for an experimental, interdisciplinary, and participatory approach.

This year's project, *We Make the Treasure*, is a thought-provoking interactive sculpture by New York-based artist Paul Ramírez Jonas. His work has pushed our exploration of the potential for public art in relation to the unique Exploratorium context even further.

Nato Thompson, Chief Curator at Creative Time, New York was one of the nominators of Ramírez Jonas for this year's project. As an artist working in the public realm Ramírez Jonas has a growing reputation for advancing inquiry about the public sphere itself. We were also impressed by Ramírez Jonas' careful design of humanly-scaled interactions as a way of illuminating and generating further reflection on complex social questions of ethics and value. As celebrated scholar of socially engaged art Shannon Jackson describes in her essay "Public Treasure" in this catalog, Ramírez Jonas creates artworks in which "sociality" becomes the subject and medium of our investigation.

We were intrigued by Ramírez Jonas' initial idea to develop a site-specific work exploring ideas related to exchange and value. In her photo essay Marina McDougall, Director of the Exploratorium's Center

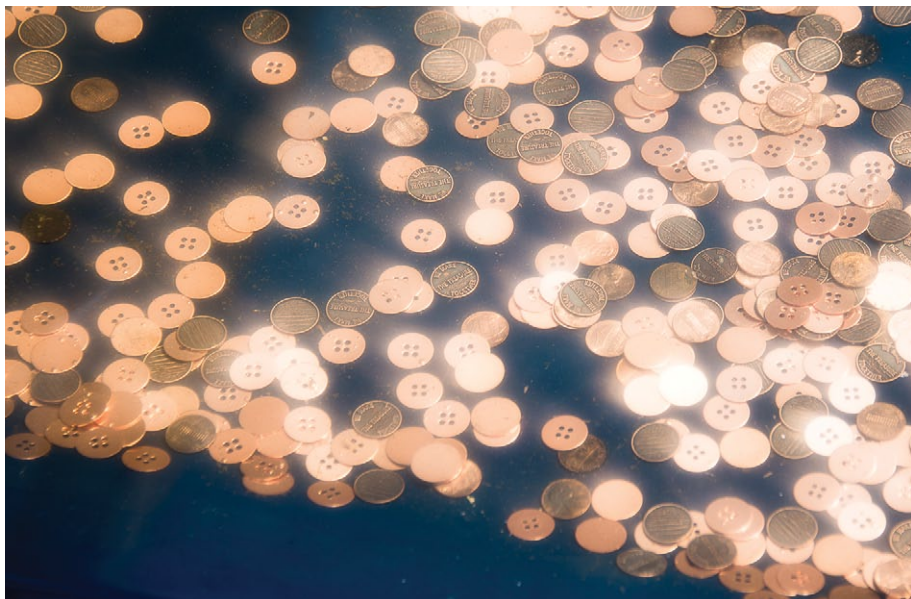

*We Make
the Treasure*
installation detail

for Art & Inquiry, elucidates aspects of Ramírez Jonas' research into our city's maritime histories of sunken and abandoned ships. In particular, the little known nineteenth-century schooner, the *Beeswing*, which sank off the coast of San Francisco in 1863, is a key historical referent for *We Make the Treasure*.

Thompson's essay *Civil Society by Way of Keys, Coins, and Everyday Life* traces how *We Make the Treasure* builds upon the rich body of work that Ramírez Jonas has created over the last decade by using everyday objects to serve as vehicles for his participatory artworks exploring social phenomena. A conversation between Ramírez Jonas and social psychologist Dr. Hugh McDonald, principle investigator of Science of Sharing, an exhibit-development project supported by a grant from the National Science Foundation, highlights the rich exchange that occurred between the artist and the Exploratorium staff during the inception of this project.

For the last forty years artists embedded within the culture of the Exploratorium have created rich new learning experiences for the public. This catalog helps to capture the ideas and conversations that underlie the process of developing *We Make the Treasure* and that will continue to resonate for all of us.

ACKNOWLEDGEMENTS

Marina McDougall

It has been an extraordinary pleasure for the Exploratorium to work with Paul Ramírez Jonas over the past two years on the development of our 2014 Over the Water commission. Kind, generous, inspiring, humorous, and hard working he has deepened our thinking about the complex juncture where art and its publics come together in significant ways, and has indelibly altered our understanding of engagement.

Moving between his studio in Brooklyn and our site at Pier 15, Ramírez Jonas has worked with a wonderful and extensive cast of contributors (listed on page 72), all of whom lent their various talents to the research and development of *We Make the Treasure*. We'd like to thank them all and note in particular, the efforts of a few key individuals.

At the Exploratorium, the Over the Water program is stewarded by the Center for Art & Inquiry (CAI) in collaboration with the Studio for Public Spaces (SPS). Kirstin Bach, the CAI Program Manager, was invaluable in helping us to navigate the complex processes associated with realizing this multi-faceted public artwork with sensitivity and thoughtfulness. SPS team members were vital partners in the conception and realization of *We Make the Treasure*. SPS Project Director Steve Gennrich and Design Engineer Jesse Marsh conducted many inspiring sketch sessions with Ramírez Jonas in the early stages of the project. Subsequently Marsh, and fellow SPS Design Engineer Adam Esposito, carried out the challenging processes of prototyping and building the crane and "bubble ship" elements of the work.

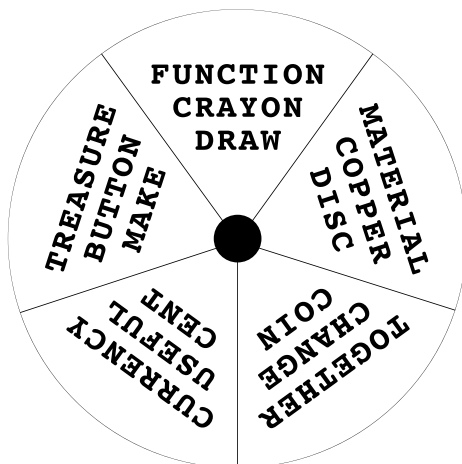

*We Make the
Treasure, prototype
for wordplay
multiple*

We would also like to extend our gratitude to Nato Thompson, Chief Curator at Creative Time for his perceptive and spirited participation as Advising Curator for this year's Over the Water project as well as his contribution to this catalog. We deeply value the reflection made possible through writings about our arts activities and so are grateful, too, to Shannon Jackson, Director of the Arts Research Center at the University of California, Berkeley for her insightful essay, and to Dr. Hugh McDonald, Exploratorium staff social psychologist, for sharing his rich exchange with Ramírez Jonas in this volume.

It has been a great privilege for us to work on this second Over the Water catalog with CAI Advisor Leigh Markopoulos, an extremely accurate and insightful editor who helped us to shape the texts you are reading in considerable ways. Thanks also to John Borruso for the elegant design of the pages that you hold in your hands.

We continue to be grateful to Bill Fisher, Exploratorium Trustee, for his leadership in stewarding the arts at the Exploratorium, particularly in his role as the chair of the recently formed Exploratorium Arts Committee. We deeply appreciate his enthusiasm and encouragement as we continue to develop and experiment with the new Over the Water program.

In Ramírez Jonas' Studio we would particularly like to thank Aida Šehović for keeping our bi-coastal collaboration running so seamlessly.

And finally a very special thanks to Indra Ramírez Antoni for conducting important user testing for a younger set.

We Make the Treasure Together.



We Make the Treasure
offerings: crayon penny,
copper blank, penny,
button, custom made coin

CIVIL SOCIETY BY WAY OF KEYS, COINS, AND EVERYDAY LIFE: PUBLIC ARTWORKS BY PAUL RAMÍREZ JONAS

Nato Thompson

Take a step back. Think about your daily life in terms of simple habits. You walk. You say hello to people. You exchange money for things. You agree or disagree with things said. For many of us these actions are second nature; we do not often reflect on their habitual nature, nor on the philosophical value systems they imply. For Ramírez Jonas personal moments of decision-making continue to be a source of inspiration, reflection, and exploration in his participatory public artworks.

Ramírez Jonas' installation at the Exploratorium, *We Make the Treasure*, builds upon his interest in public space, interaction, and exchange. His past projects draw upon the prosaic to illuminate our individual value systems. Understanding how Ramírez Jonas' artistic and social concerns are embodied in his past projects helps to reveal the underlying logics of *We Make the Treasure*.

Ramírez Jonas' project *Key to the City*, commissioned by Creative Time in 2010, transformed the traditional ceremonial award of a symbolic key to the city into a participatory public artwork. Instead of a mayor bestowing a key on a single distinguished recipient, thousands of citizens were empowered to confer a key upon one another. Ramírez Jonas' key, unlike the symbolic key, was also functional: it allowed recipients access to a number of designated sites throughout the five boroughs of New York City.

The symbolic conferral of the key to the city dates back to the Roman era when fortified cities were protected by locked gates.

Originally, bestowing a key to the city afforded physical access and implied trust. In this spirit Ramírez Jonas worked with the city of New York to persuade then Mayor Michael Bloomberg to devolve his authority over the official key and make it available to all the residents and visitors to the city for a whole month.

The project essentially comprised two parts: an award ceremony and the subsequent use of the keys. Interested participants were invited to make their way to a kiosk located on a small, but carefully demarcated, green common in the center of the madhouse known as Times Square. Instructed to arrive in pairs, participants awarded the keys to each other, for whatever reasons they deemed significant—in one case, for example, a mother gave her daughter the key for receiving good grades in school and in turn received the key from her daughter for navigating successfully through Times Square.

After the words were exchanged and the documents signed and filed in binders on display, the participants took possession of their key to the city. Twenty thousand copies of a single master key were produced, distributed, and used. Participants also received a passport of sorts that provided information about the twenty-four sites accessible via the key. A veritable taxonomy of public space, the sites ranged from the official (the Mayor's house, Gracie Mansion), to the infrastructural (the pedestrian walkway of the George Washington Bridge) and the more humble, such as the kitchen of Taqueria Nixtamal in Queens where visitors were invited to learn how to make tortillas by the chefs. Hosts at each site were free to determine what kind of interaction they wanted to have with visitors. In a sense, the aggregate of these sites and interactions produced a geographic poem about access, belonging, and interpersonal connection.

Key to the City is an important example of a contemporary art project committed to transformative possibilities in the public sphere. Ramírez Jonas cites his discovery of the writings of Frankfurt-school philosopher Jürgen Habermas as seminal in the development of his understanding of what constitutes this sphere, and in particular Habermas's 1962 treatise, *The Structural Transformation of the Public Sphere*, which proposed the emergence of a shared civic realm in Europe during the 1700s. Understood as distinct from what Habermas terms the "representational" culture of governance, in which ruling bodies or monarchs performed their uncontested authority for a passive public, the new sphere was animated by free, critical



The artist and participants, *Key to the City*, 2010. Presented by Creative Time, Times Square, New York City

discourse. It was a space of debate and conviviality and was accordingly linked with the emergence of coffee shops, newspapers, and fraternal orders. At heart, Habermas' proposition is marked by an interest in the production of sites where free communication is possible. Ramírez Jonas in turn produces participatory artworks that generate awareness that this is an ongoing and evolving process. Many of these works also evince the artist's long-standing interest in written contracts and spoken statements. For Ramírez Jonas, "speech-acts," a philosophical term applied to utterances that have a performative function ("I award you this key"), are extremely important and in *Key to the City*, they played as central a role as the keys themselves.

"Speech acts" and the public sphere are significant to Ramírez Jonas, not only for artistic reasons, but also for political ones. These dual interests coalesce in his use of everyday items such as keys. Interestingly, the artist has a long history with these pocket-sized



Mi Casa Su Casa,
2005 (detail).
Performance lecture
with key blanks
for exchange

talismans. His performance lecture *Mi Casa Su Casa* (2005), for example, was conducted in schools, corporations, jails, universities, and clubs along the San Diego/Tijuana stretch of the U.S./Mexico border and offered a genealogy and history of specific sets of keys belonging to residents in these areas. At the end of each lecture, Ramírez Jonas offered audience members a copy of the key to his house, in exchange for a copy of one of their keys. The copies were made on site by the artist and exchanged with other audience members in a mass act of public trust.

What becomes evident in *Mi Casa Su Casa* is a connection between the intimate and vastly geopolitical. Focusing on people who inhabit the border spaces of San Diego/Tijuana, Ramírez Jonas illustrated

the very personal and everyday ways in which individuals are affected by themes of access and exclusion. Oscar, for example, lives in Mexico but works in the United States. He carries two distinct sets of keys: one related to his activities in San Diego where he lives and works most of the time; and another for his parents' home in Tijuana, where his family resides. While keys might seem to be particularly prosaic and mundane objects, they thus can be seen also to imply narratives of politics and power, of ownership and dispossession.

Also in 2005, Ramírez Jonas produced *Taylor Square*, a permanent public artwork in Cambridge, Massachusetts. By fencing off part of a traffic triangle, he transformed a small patch of concrete into a miniature grass park, complete with a stone bench and flagpole. By enclosing an already existing piece of public property, and redesigning its access, the project emphasized the notion of ownership. The significance of *Taylor Square* as a common, a publicly owned and shared piece of land, was underscored by a further act of complicity: the mailing of 5,000 copies of a specially-cut key that allowed entry to the miniature park to neighborhood residents. An inscription on the

Taylor Square,
2005. Permanent
public park
for the City of
Cambridge, MA





Keys for the Ciccillo Matarazzo Pavilion front door, made and distributed for *Talisman*, 2008. 28th São Paulo Biennial, Brazil

key prompted recipients to copy and pass along their key, should they wish to do so, inverting the usual instruction to “not copy” which accompanies security keys.

For the 28th São Paulo Biennial in 2008, Ramírez Jonas conceived a project titled *Talisman*, which took as its starting point the entrance to the massive Ciccillo Matarazzo Pavilion, the main venue for the exhibition. Obtaining permission to replicate the Pavilion’s front-door key, Ramírez Jonas was able to offer a copy of it to 5,000 visitors. The key gave participants access to the museum, even after museum hours. In exchange for the key, they signed a contract that made explicit the unwritten rules of conduct that a museum and its public tacitly accept (for example, “don’t touch the art”), and outlined

areas of mutual responsibility as regards safety, property damage, theft, etc. Participants were also encouraged to hand over one of their own keys to be displayed as an equal, and visible, gesture of trust and responsibility.

In these works the emphasis does not center on the materiality of keys, but on the underlying contracts, laws, expectations, actions, and potentialities of the public sphere that are embodied in these objects. By exploiting these associations, Ramírez Jonas makes the implicit explicit. In *Talisman*, for example, the artist translated the social behaviors observed by museum attendees the world over into a written and signed agreement. In this way, he engendered a new consciousness around accepted, required, and instinctive social and public behaviors.

While Ramírez Jonas does not work exclusively with keys and coins, his interests are expressed primarily through the materials we circulate and exchange in our daily social interactions. These objects accrue extra significance through their use as art media. Recontextualized, they offer opportunities for participants to contemplate a broader range of choices, possibilities, and social interconnections. If keys underscore notions of access and ownership, then coins perhaps offer a moment to consider exchange and value.

WE MAKE THE TREASURE

The Exploratorium, a non-traditional art venue, afforded Ramírez Jonas a different context in which to further his explorations of exchange, curiosity, and sociality. The institution's combined focus on science, art, and education through public participation, affords unique opportunities for challenging many of the underlying assumptions operating in more traditional arts contexts. In this interdisciplinary environment collaboration flourishes. Artists, like Ramírez Jonas, can exchange ideas with a range of staffers, from engineers and social scientists, to curators and microbiologists.

Ramírez Jonas' *Over the Water* project at the Exploratorium began in the summer of 2013. During an early site visit the artist met the exhibit developers who create the museum's participatory exhibits intended to explore subjects as diverse as gravity and fear.



Exploratorium
exhibit spare-
part bins

In the machine shop, he saw arrays of bins containing spare parts for exhibits. Ranging from beach balls to metal springs, and labeled mysteriously “disappearing glass rods,” “distorted room,” and “energy from death,” the contents of the bins pointed toward a vast infrastructure geared toward inquiry.

Ramírez Jonas also met with staff members whose areas of interest run strikingly parallel to his own. In particular he was drawn to Hugh McDonald, Associate Curator for the museum’s West Gallery, which features human phenomena exhibits. McDonald is also the Principal Investigator for a National Science Foundation supported exhibit development project entitled Science of Sharing. Take that in for a second: the science of sharing! As part of this initiative McDonald’s team developed an exhibit called the Give and Take Table. At the beginning of each day this table is stocked with small items from the museum’s gift shop. Visitors are invited to trade for these items. The introductory text reads, “You share this table with everyone else at the museum. Nobody enforces the ‘take and replace’ rule, and nothing prevents you from replacing a nice item with garbage. Researchers studying social dilemmas like this have found that we often want to act in the community interest, but we’re also tempted to maximize our personal gain. And when we don’t think that others will act with the group in mind, we’re less

likely to do so ourselves.” The level of exchange slowly, but surely, degenerates throughout the day as objects of value are exchanged with objects of lesser value until by the end of the day all that remains is an abject set of items such as used toothbrushes and candy wrappers. The table might not offer the most optimistic demonstration of human nature, but perhaps that is exactly what makes it so interesting.¹

In some ways, the Give and Take Table could be considered an analogue method for demonstrating what is often referred to as the “tragedy of the commons.” A paper written by American ecologist Garrett Hardin and published in the journal *Science* in 1968, the “Tragedy of the Commons” theorizes the impact of individual decisions in complex social systems, and draws heavily on an early 19th-century pamphlet by British economist William Foster Lloyd, which addressed the uses of common grazing areas. According to Lloyd, who was ultimately to be proven right, too many sheep grazing on the commons leads to destructive overgrazing, impacting the environment adversely, although in the short run individual shepherds might profit from larger herds. Hardin applied Lloyd’s logic to the rising world population and its impact on world resources. He controversially believed that if the state did not interfere by subsidizing families and thus encouraging population growth, the natural system would simply keep the number of people down. Hardin’s conclusion was that the tragedy of the commons was not, in fact, occasioned by individuals, but rather by the larger (governmental and social) structures individuals operate within. It’s a bitter pill to swallow.

The phrase the “tragedy of the commons” has increasingly been used as a shorthand way of referring to the strategic use of resources in complex systems of self-interested actors. Today, attention has shifted to questions of sustainability and environmental degradation. In our era, the question of the short versus the long term in connection with self-interested decision-making resonates profoundly with each new flood, drought, or hurricane that sweeps across the globe.

To return to the Exploratorium, it was Ramírez Jonas’ meeting with McDonald which sparked new considerations about exchange, personal decision-making, and public art for the artist. As he further considered the Give and Take Table Ramírez Jonas wondered if the behaviors and questions engendered by its exchange mechanism

possessed not only theoretical implications, but also pragmatic and formal ones. Perhaps the design of the table, and the modes of exchange it promoted, produced the conditions in which the exchange of common goods actually degraded over time and perhaps, if designed differently, the results would be also be different? It is a perfect set of questions for an artist who creates situations for people to explore basic human values and interconnectedness.

In contrast to *Key to the City*, Ramírez Jonas hoped to encourage multiple points of entry into *We Make the Treasure*. Instead of a clear-cut, or more linear format of exchange, Ramírez Jonas wanted to keep the options open for the public to engage in a somewhat more unscripted, inquiry-based Exploratorium-like fashion.

Located on the Embarcadero, the public promenade that fronts the Exploratorium campus, the work takes the physical form of a twenty-foot long dory laden with barrels. Situated between Piers 15 and 17 where joggers and tourists mingle with visitors to the Exploratorium, this somewhat curious, and theatrical, installation lures both the meandering passerby and the destination visitor for a closer look, at which point it reveals itself as an elaborate exchange mechanism of sorts. Carved into the dory's cargo of barrels are hundreds of rounded recesses, like those one finds in the albums used by coin collectors. There are also a dozen or so coin slots, which recall at once piggy banks and the payment receptacles of public telephones. In this way the work alludes to the various ways in which we encounter and interact with coins.

An assortment of penny-shaped objects studs the barrels and fills the open slot mechanisms. Some are made of plain copper, molded wax, or fashioned into buttons, while others are actual pennies and specially minted coins inscribed with the legend, "We make the treasure together." Adjacent to the boat stands a crane that visitors can activate in order to lower a canvas bucket down over the promenade railing and into the San Francisco Bay. By looking over the railing, participants can follow the pail's trajectory toward what appears to be the bubbling outline of a sunken vessel. The watery contents of the bucket can be cranked back up to the pier, and over the beached boat, soaking the cargo of barrels and coins. Wetted by the Bay water, the coins develop a patina over time, which mimics the look of sunken treasure. As the "currency" for an engagement with the larger work itself, they provoke a number of decisions about whether



*We Make
the Treasure*
installation detail

to take one or two, which one/s to take/whether to engage with the work at all and/whether to leave anything in exchange. Outlining the rim of the boat, the following poetic didactic offers a series of possible prompts for public interaction:

TAKE A PENNY, LEAVE A BUTTON · TAKE A COIN, LEAVE SEAWATER · TAKE A CRAYON, LEAVE A FORTUNE · TAKE COPPER, LEAVE TOGETHER · TAKE A PRECIOUS ITEM, LEAVE COPPER · TAKE A TREASURE, LEAVE A DRAWING · TAKE SEAWATER, LEAVE A COIN · TAKE A BUTTON, LEAVE A PENNY

The possibility of leaving coins at *We Make the Treasure* relates to other coin usage in Ramírez Jonas' work. In his project from 2008, titled *Well*, one of the ubiquitous NYC paper coffee cups bearing the legend *It's our Pleasure to Serve You* sits atop a pedestal, at the height that a standing person asking for money might hold his or her cup. The bottom of this cup has been excised, as has the



We Make the Treasure in use

corresponding surface area of the pedestal, which in turn is filled with water. Visitors are free to flip a coin into the cup in a gesture that effectively mimics giving money to a homeless person, but that also draws on the universal human compulsion to throw money into receptacles. The unexpected sound of the coin hitting water confirms this work's dual property as an alternative form of wishing well.

In interacting with open-ended artworks like these the public must to some degree try to figure out what is expected of it, but there is always the possibility of improvisation. In the case of *We Make the Treasure*, visitors have been tempted to scrawl on the barrels and stuff handwritten notes into the coin slots. One such missive reads, "Don't take the sun for granted," and is accompanied by a drawing of a squiggly sun.² Similarly, in *Key to the City*, when opening the control box of a street-lamp located in Bryant Square Park, key holders were often confronted with myriad notes written by previous participants.

It has been said that art is that thing we do not recognize until after we have experienced it. That is to say that at its heart art is a mystery, and mysteries, when they are encountered, are by their very nature confounding. Despite the artist's intentions, *We Make the Treasure* may not look like an artwork just as the coins that glimmer in the wishing well might not look like art materials. But it is no accident that the aesthetics of *We Make the Treasure* mimic those of some of the tourist attractions one can find just half a mile away at Fisherman's Wharf, such as the Musée Mécanique, a waxwork museum, and themed experiences. Both allude to, and to some extent derive from, the rich maritime history of the San Francisco waterfront. And the proximity and association with Fisherman's Wharf allows *We Make the Treasure* to present itself as yet another attraction, but also to tweak the rules by which one engages with it and what one might discover by way of this engagement. Ultimately Ramírez Jonas' works engineer spaces of exchange, communication, and value. But while the interface and the actions his works provoke may seem familiar, the open-ended nature of the exchange activated by the artist is unusual. Participation, particularly when the rules do not necessarily exist, can have its own poetic logic.

1 As Ramírez Jonas and McDonald detail further on in this publication, the exhibit itself has caused much internal debate, as many people on staff do not like the fact that it degenerates over time. It has recently been redesigned.

2 Though delightful, these impromptu contributions initially jammed up the mechanism, so the team was forced to narrow the slots to prevent further blockages.

Since joining Creative Time as Curator in 2007, Nato Thompson has organized several major projects including the annual Creative Time Summit, Kara Walker's *A Subtlety* (2014), Tania Bruguera's *Immigrant Movement International* (2011), *Living as Form* (2011), Paul Ramírez Jonas' *Key to the City* (2010), and Paul Chan's *Waiting for Godot in New Orleans* (2007). Previously, he worked as curator at MASS MoCA where he completed numerous large-scale exhibitions. Thompson has edited several catalogues including *The Interventionists* (2004), *Becoming Animal* (2005), *Experimental Geography* (2006), and *Living as Form* (2011). His book *Seeing Power: Socially Engaged Art in the Age of Cultural Production* will be published by Melville House in the summer of 2015.



We Make the Treasure
installation detail

PUBLIC TREASURE

Shannon Jackson

A family of four walks along the Embarcadero in San Francisco. One dad taps on his cell phone, the other carries bags from the Farmers Market nearby and tries to corral their young daughter who is spinning around and around on the broad sidewalk. Their older son (who is maybe middle school age) shuffles behind. After passing Pier 9 and avoiding a skate boarder, the family happens upon Pier 15 where a small crowd has assembled around a boat bearing a stack of barrels and a mast-like appendage poised over the water.

“What’s this?” cries the little girl, “can we try it?”

The first dad looks up from his cell phone. “Um, I think so.”

She runs to take her place in line, watching as others rotate a crank that hoists a bag of saltwater onto the pier. The first dad returns to his cell phone; the other sits on a nearby bench and unburdens himself of his bags. The son sighs and meanders toward the pier’s railing; he leans against it and looks down at the water below.

“It’s my turn,” calls the little girl who begins to turn the crank. The canvas bucket jostles and spills as her arm pumps round and round. “It’s spilling. Daddy, can you help me?”

The texting dad looks up and over at his partner whose closed eyes face up to the sun. Next, he looks over at his son.

“Mark, can you help your sister?”

No response.

“Mark?”

“What?” asks the boy, jostled out of contemplation. “Why can’t *you*?”

But two other adults standing near the barrels have already reached for the bag. “Keep turning,” says one. The little girl turns as the two of them guide the bag of water, dumping it into the prow of the boat. Other children are reaching into the boat filled with water, picking up small handfuls of coins from the bottom. The little girl lets go of the crank and lurches toward the front of the boat, as if to hold on to the water that she found.

The dad finishes his text and walks over to the group, thanking those who helped his daughter.

“Look at these, Daddy,” she says, holding a few penny-sized discs out for him to see. “Can we keep them?”

“Oh, no, honey,” he says, “we need to put them back. We haven’t even paid admission.”

We Make the Treasure makes its appearance at a time when the terms “public” and “art” are much-debated, a fact that has consequences for the field of “public art.” The works of Paul Ramírez Jonas have consistently mined these debates and their consequences, often functioning as vehicles and Rorschach tests for asking how we think artworks and their publics come into being. Indeed, we might even ask those questions of ourselves in contemplating the scenario that I described above. Does a public come into being in the encounter with a work that may or may not be defined as “art”? Does that encounter in this case depend upon the pier, the swept sidewalks, or the context of the Exploratorium? Does public-ness also depend upon physical and verbal interactions—the cranking, the questioning, the thanking—amongst grown-ups and children tenuously linked and inconvenienced by each others’ presence? Building upon Nato Thompson’s reflections in this volume—as well as the statements of the artist Paul Ramírez Jonas and Exploratorium curators—this essay situates Ramírez Jonas’ *We Make the Treasure* within a wider conversation across art and social theory.

If “public art” is in fact a field of practice, its history precedes the creation of the term. One can track genealogies across eras and regions of the world, finding public impulses in the graphic symbols of cave paintings, the statuary monuments of ancient civilizations, the commissioned frescos of cathedrals, the memorials of historical battles, and all varieties of artful expression subsidized by rulers, conquerors, or civic officials charged with addressing—and thereby



*We Make the
Treasure in use*

constituting—a public through art. Of course, the term became more ubiquitous amongst the citizens of 20th-century cities whose (usually elected) officials graced civic spaces with sculptural works that promised beauty, contemplation, and collective uplift. This model of public art continues, despite the fact that some question the “plop art” parameters of the form. Adjacently, however, artists, curators, and citizens find themselves encountering works whose parameters differ. If one model finds the artist working hermetically in her studio, releasing a finished work onto and into a public, other models start with the site of arrival. Practicing what Suzanne Lacy has called “new genre public art,” artists are now trained to excavate the material, historical, and sociological conditions of the commissioning site, crafting public art work that responds to local conditions.¹ Those conditions often include volatile political and economic factors that might exceed the values and original intentions of the commissioning body. Indeed, as public art historian Rosalyn Deutsche has



*We Make the
Treasure in use*

demonstrated, the ever-expanding parameters of public art have exposed the fragility and inequity of so-called public space.²

But perhaps we shouldn't be surprised by what public artists are turning up, given how fraught even democratic conceptions of the public sphere have been from the beginning. As Nato Thompson reminds us, the renowned social theorist Jürgen Habermas thought he spied a truly democratic form in the 18th-century clubs and coffee houses. In Habermas' vision the public sphere is a space of deliberation based in "the medium of talk." It is a space where "private" interests are set aside, and a space where interaction evades the corruptions of commerce and the constraints of state government.³ As critics such as Nancy Fraser and Michael Warner have argued, however, Habermas did not fully fathom the exclusions created by these parameters, presuming as it did educated white male property owners for whom the issues of "women" or "slaves," for example, were private matters unworthy of public deliberation.⁴ Such an intra-group model

of public relations misrecognizes what, for urban sociologist Richard Sennett, is key to any dynamic conception of the public: a willingness to engage a public of “strangers,” a commitment to sustain the lives of people unlike us and whom we may never know.⁵

Now, in what we have come to call our “neoliberal” moment, other elements of the model are heatedly debated. Some question and some celebrate the “stark separation” that Habermas called for between the public sphere and the public sector (i.e. between democratic deliberation and the operations of state governance). On the one hand, we are presented with one version of the “tragedy of the commons” which recounts the untoward effects of state “intrusion” into the sphere of “common” relations.⁶ On the other, we face another take on the same tragedy, the unwillingness of individuals to take responsibility for a shared commons, i.e. the reluctance to sustain the “common” health, education, and welfare of the citizens around us.

These opaque and complex public puzzles circulate in varieties of contemporary public art practice, and they are both implicit and explicit in much of Paul Ramírez Jonas’ work, whether he is foregrounding dissent in Honduras’ public monuments, mobilizing the public sector as an art conservation crew in Cambridge, sharing the key to his home with strangers along the San Diego/Tijuana border, handing out “keys to the city” in New York, or “re-making treasure” in San Francisco.

We Make the Treasure incorporates other social art genealogies, however, as well as other conversations within the social sciences. As recounted elsewhere in this publication⁷, Ramírez Jonas found uncanny resonance between his practice and the structures and goals of the Exploratorium’s social science exhibitions. Exhibits such as the Give and Take Table and Donation with Contemplation were created by the Museum’s staff in order to examine the science of sociality and the nature of social exchange as intently as the Exploratorium examines physical and biological phenomena. Social psychologist Hugh McDonald’s framing of this turn is telling. At the Exploratorium, “we always regard social interaction as a nice side benefit, but don’t really design the exhibit to be about that. People don’t necessarily come to a place to have a social interaction, especially with a stranger, so probably the single biggest challenge we still face is getting strangers to interact.”⁸ Rather than conceiving sociality as a “side

benefit,” these exhibits position “interaction” as the object of inquiry. As it happens, that goal has its parallel in a contemporary art context where artists and curators now position “sociality” as a central medium and material of the art event.

In art practices variously called social, relational, participatory, interactive, performative, and community-engaged, artists focus on creating structures that elicit exchange and prompt self-conscious reflection on the structure and ethics of interaction. Ramírez Jonas’ work—and *We Make the Treasure* in particular—is influenced by many of this movement’s central practitioners, especially Felix Gonzalez-Torres. Gonzalez-Torres’ famous “stacks” and “spills” of paper or candy in the art gallery, offer visitors the choice to take a piece with them as they leave. Visitors encountering a work that displays the effects of prior choices are required to speculate on the effects of their own decision for future visitors. As Nicolas Bourriaud, the author of a contested text, on relational aesthetics, asks of this work: “What position should be adopted when looking at a work that hands out its component parts while trying to hang on to its structure?”⁹ The answer in part relies upon our own willingness to avow our relation to these parts and this structure. Consider the paper and candy next to the keys and coins of Ramírez Jonas’ work. What if we answered the little girl’s question, “can we keep them?” differently? How do different answers provoke more questions, about where we will keep them if we take them, about who might not have enough if we do? How will we reciprocate if we allow the coins to become gifts to ourselves? How do we participate in this work’s replenishment?

How, indeed, do *we* make treasure? In the end, we can see this work, like so many of Ramírez Jonas’ projects, as a stitching together of public art and relational art traditions, a joining of a systemic imaginary to the micro-world of highly intimate exchange. The piece partakes of the public memorial, though in remembering the lost ship *Beeswing*, it arguably recalls a memory that many San Franciscans did not know was theirs. Its ghost re-appears in what Ramírez Jonas calls “the spine” of the piece, the outline of bubbles that draw the schooner’s perimeter in the water. For that middle school boy, this bubbling image was the most captivating element of the work; watching it from his perch at the handrail also allowed him a place to contemplate without feeling obliged to heed his sister’s call for a different kind of “participation.” This stitching together of macro and

micro requires and enables new calibrations of what Habermas might have called public and private. Indeed, in the space of a few minutes, the work modulated relations amongst family members' and amongst strangers. Walking along and inside a private/public dialectic, it also allowed each family member to take a breath and a break from the routines of kinship—whether by typing on a phone, playing on a boat, relaxing on a bench, or leaning against a handrail. The treasure made by this piece lies in the value we place on discs that are not quite pennies, on histories that we did not know we shared, and on interactions enabled by a set of barrels, a crank, water, bubbles, all assembled on a public sidewalk on a pier near the Bay/ocean.

We are the treasure we make.

- | | |
|--|---|
| <p>1 Suzanne Lacy, "Introduction," <i>Mapping the Terrain: New Genre Public Art</i> (Seattle: Bay Press, 1994), 19.</p> <p>2 Rosalyn Deutsche, <i>Evictions: Art and Spatial Politics</i> (Cambridge, MA: The MIT Press, 1996).</p> <p>3 Jürgen Habermas, <i>The Structural Transformation of the Public Sphere: An Inquiry into a Category of Bourgeois Society</i> (Cambridge, MA: The MIT Press, 1991).</p> <p>4 Nancy Fraser, "Rethinking the Public Sphere: A Contribution to the Critique of Actually Existing Democracy," <i>Social Text</i>, No. 25/26 (1990), 56–80; Michael Warner, <i>Publics and Counter-publics</i> (New York: Zone Books, 2002).</p> | <p>5 Richard Sennett, <i>The Fall of Public Man</i> (New York: W.W. Norton & Company, Inc, 1974), 17–18.</p> <p>6 Garrett Hardin, "The Tragedy of the Commons," <i>Science</i> Vol. 162, No. 3859 (Dec. 13, 1968), 1243–1248.</p> <p>7 Paul Ramírez Jonas in conversation with Hugh McDonald, page 43.</p> <p>8 <i>Ibid.</i>, page 54.</p> <p>9 Nicolas Bourriaud, <i>Relational Aesthetics</i> (Dijon: Les Presses du Réel, 1998), 39.</p> |
|--|---|

Shannon Jackson is the Richard and Rhoda Goldman Chair in the Arts and Humanities and Director of the Arts Research Center at the University of California, Berkeley. Her most recent book is *Social Works: Performing Art, Supporting Publics* (2011). Previous work has explored the relation between performance and Progressive Era social reform (*Lines of Activity*, 2000) and between performance and the disciplines of higher education (*Professing Performance*, 2004). Her forthcoming book about the relation between new media and theater in the work of The Builders Association is being published by M.I.T. Press in 2015. A 2014 Guggenheim Fellowship awardee, she additionally serves on assorted boards, has published in numerous journals, collections, and catalogues, and is currently working on a number of community art projects in the Bay Area.

PAUL RAMÍREZ JONAS, *WE MAKE THE TREASURE*, 2014





Paul Ramírez Jonas studio with *We Make the Treasure* in process

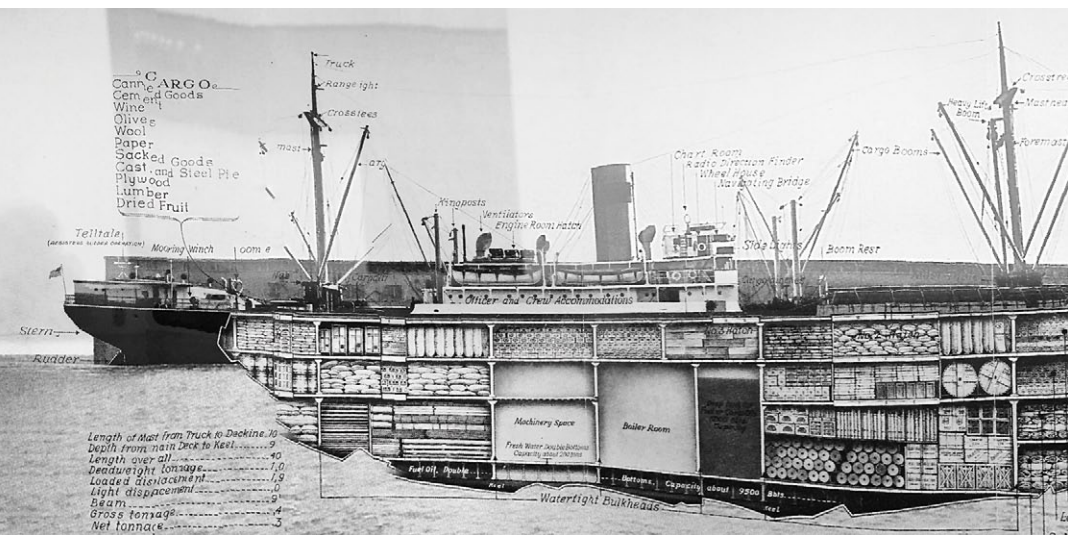

Clockwise: Cross section cutaway of typical cargo vessel from the book *Handling and Storage for Cargo*, 1942; research mock up; oxidation tests; *We Make the Treasure multiple*



T	A	K	E	●
C	●	P	P	R
C	R	A	Y	●
A	●	C	●	I
B	●	U	N	T
B	U	T	●	N

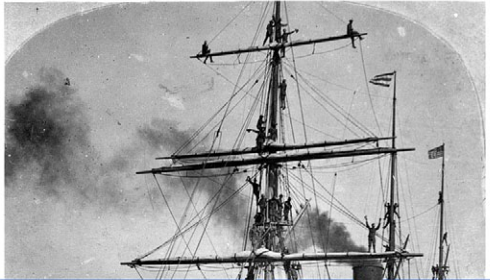

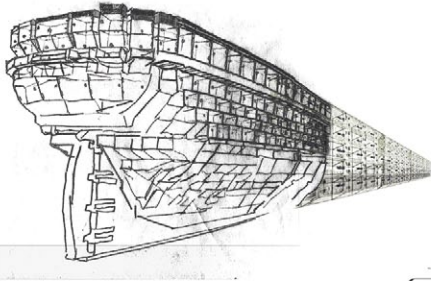

Clockwise from top left: early sketch with cranes; engineering diagram of crane; site map with ship outline; cargo ship research sketch

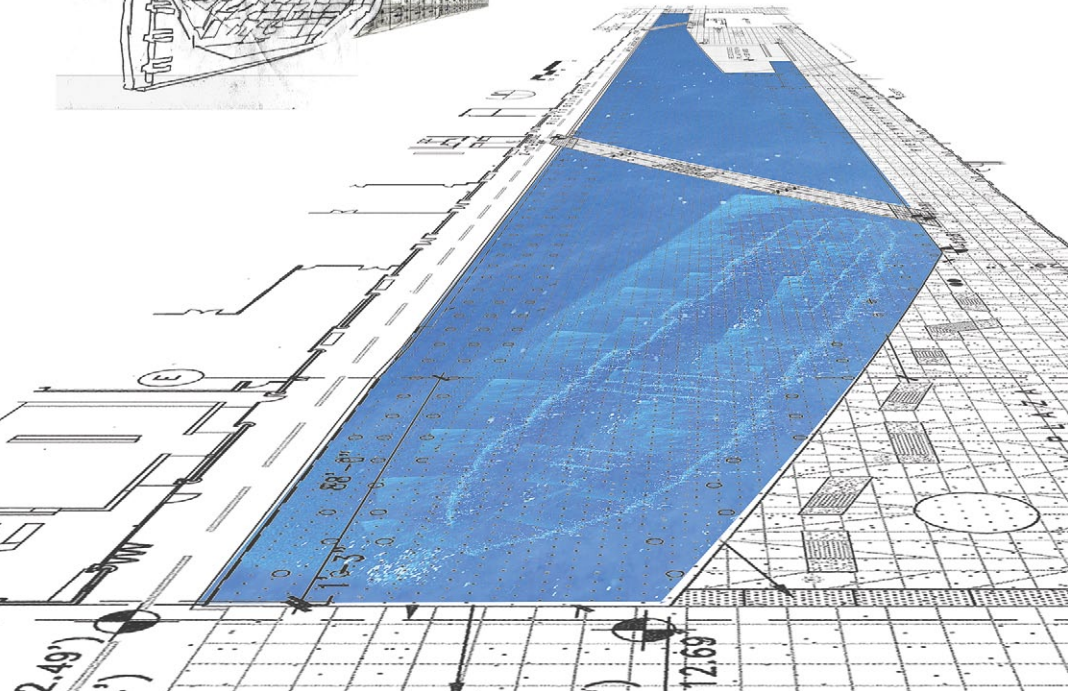

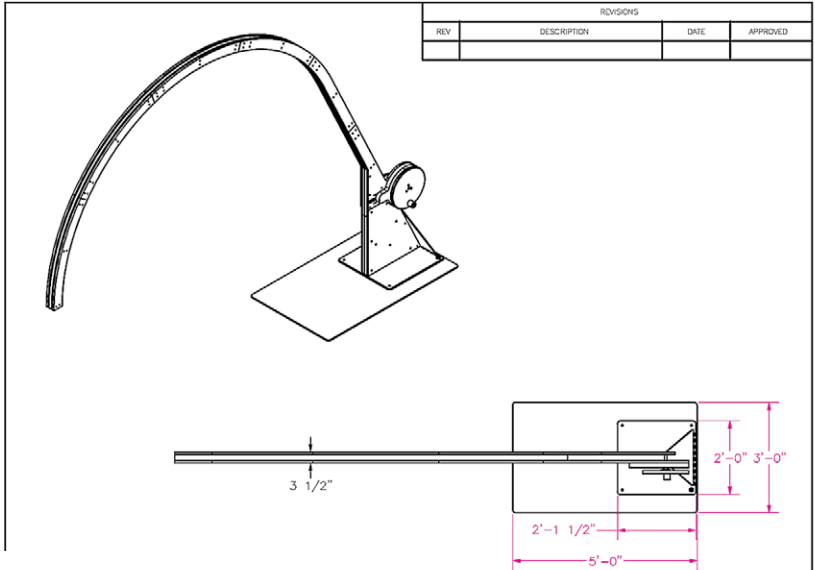

REVISIONS			
REV	DESCRIPTION	DATE	APPROVED

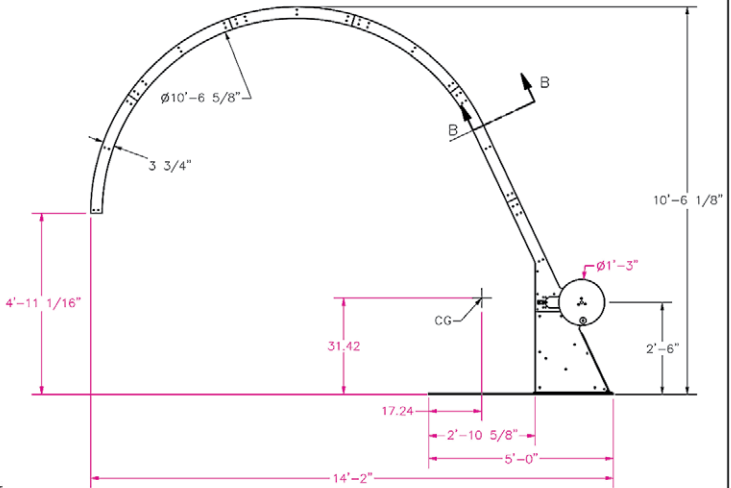

- NOTES:
1. INTERPRET DRAWING PER ANSI Y14.5.
 2. REMOVE BURRS AND SHARP EDGES UNLESS SPECIFIED OTHERWISE
 3. OVERSIZE TAP ANODIZED PARTS
 4. MASK PRECISION BORE BEFORE ANODIZING

PARTS LIST				
ITEM	QTY	PART NUMBER	DESCRIPTION	MASS
1	1	7463-01	CRANE	468 lbmass
2	1	7463-02	LIFT ASSEMBLY	143 lbmass
<small> TITLE: REVISE PARTS LIST DATE: 2/17/2014 DRAWN: gms CHECKED: gms APPROVED: gms THE EXPLORATORIUM PRJ CRANE PROTOTYPE PART: B QTY: 1 MASS: 7463 1 48 </small>				

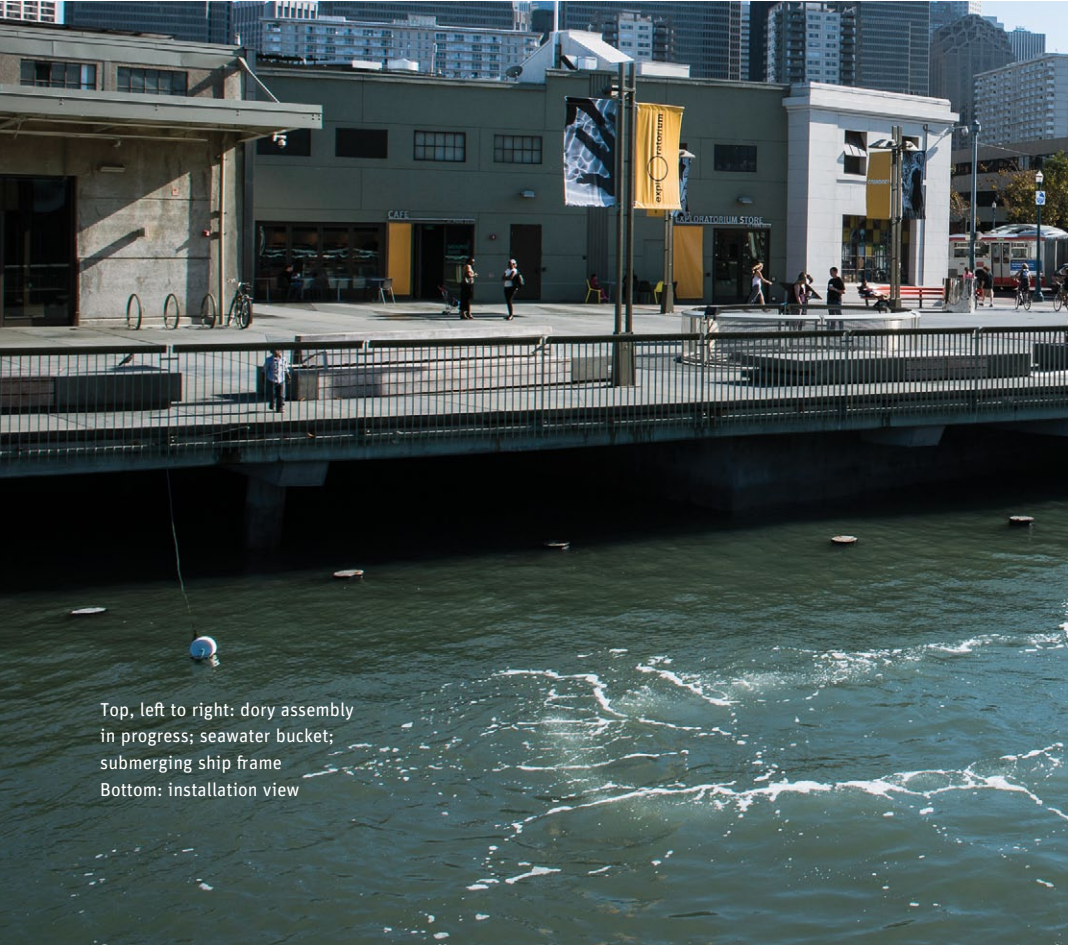

Top, left to right: dory assembly in progress; seawater bucket; submerging ship frame
Bottom: installation view







PAUL RAMÍREZ JONAS IN CONVERSATION WITH HUGH MCDONALD

Though best known for developing exhibits exploring natural phenomena such as light, electricity, magnetism, and motion, for decades the Exploratorium has also engaged visitors in experiences that explore human phenomena, including perception, memory, and language. As part of its move to Pier 15 in 2013, the Exploratorium dedicated the new West Gallery to explorations of social behavior and human cognition. Dr. Hugh McDonald, a social psychologist, has helped to lead the development of this space. Currently, he is the principal investigator of Science of Sharing, an exhibit-development project supported by a grant from the National Science Foundation. McDonald and Paul Ramírez Jonas discovered shared concerns related to the development and reception of their respective work during the artist's site visits to the Exploratorium. They discuss some of their mutual interests in the following conversation, which took place on July 22, 2014.

Hugh McDonald: I thought that we could start by exploring what you were trying to evoke in the participants of *We Make the Treasure*, what you thought the work might “do.”

Paul Ramírez Jonas: I think that you and I come from different traditions and systems of making meaning, and measuring that meaning. For example, as an artist, I'm not usually concerned with measuring meaning, right? We artists think we're making meaning. We don't try



Exploratorium
Give and Take
Table, most
recent iteration

to harvest data. But when I saw the Exploratorium's Give and Take Table¹ in the West Gallery, I recognized its similarities to some of the work I've made. I saw that the table was set up to observe and measure something, and then thought about the form of the table, and how that encouraged the process.

I'm always interested in how I can embed the "tragedy of the commons," or ideas with the potential to become cultural narratives, into my work. I'm also interested in pre-existing stories or narratives that I can insert my work into, which makes things much more difficult to measure, but equally gives me a larger formal arsenal, if that makes sense.

HM: It does. It raises a question for me, though, which is how do you evaluate whether your piece is a success? Do you use some objective rubric about how people treat it or what they do? Do you say, oh, it's not working the way I intended or, oh, what people are doing is exactly what I was hoping for? What do you look for?



Exploratorium Give and Take Table, exhibit prototype

PRJ: I look to see if people are participating. If a public convenes around your work then you already know something is working well. But it’s tougher to gauge the nature of that participation when the work exists outside the frame of an institution, because people may not necessarily have come to see your exhibit specifically. It’s a little harder to judge whether they are participating in the intended way or whether they are actually inventing their own ways to participate, which I usually see as a successful outcome.

HM: In some ways that’s very much like one of the things that sets the Exploratorium apart from other museums. Although we may have a concept that we think is really important and that we want some visitors to get, or think about, we also very much prize people using an exhibit in an unexpected way, and doing something different with it than we originally envisioned. We shouldn’t just be making something that transmits information or knowledge. We should also be learning from the visitor response/interaction.

PRJ: Right. The hard thing for me is to get myself in the frame of mind to accept that anything the public does is okay.

HM: That discussion happens internally at the Exploratorium—what are the appropriate kinds of behaviors from visitors and what are the ones that maybe we don't really want to see?

I think the big difference with *We Make the Treasure* is that it has a particular story attached to it that the Give and Take Table doesn't. Your piece is powered by an idea of sunken ships, and a poignant historical narrative that happened right here.

In contrast, the Give and Take Table is almost completely abstract. It's just a table, and it doesn't try to invoke or narrate, or link to any actual historical event or discussion such as the history of the commons in the UK. Although the exhibition that the table is part of does try to link to a scientific tradition, as it is designed to help people learn about, and experiment with, the scientific study of human behaviors like cooperation and collaboration.

I think we even discussed finding some way to link one to the other, like putting a sign at the Give and Take Table that says, "for an interesting story about sharing, visit this X artwork outside," and at the artwork that says, "for a different sharing experience, visit the Give and Take Table inside."²

PRJ: When I was making this piece, and also when I considered the exchange table, I wondered about the physical details that are not part of the greater narrative. For example, the last iteration of your table had a concave indentation for the exchange items to sit in, which made me think of the coin slot I am using. What does a coin slot mean in a piggy bank versus one in a vending machine? All the artworks and exhibits that we are making have a physical form and details to which meanings can adhere, so that it's hard to make something that's either 100 percent neutral or 100 percent inflected with a story. How do you deal with this kind of "contamination"?

HM: I like the word "contamination" a lot. Because these exhibits are about people and behaviors, and emotions and values, they are much more vulnerable to "contamination" than if they were about pendulums, for example.

The table was designed by our new exhibition designer. That's a real departure for the Exploratorium. Exhibits used to be designed by the developers based upon their own vision. You might end up with something very idiosyncratic made out of an old dining room table, which obviously has a huge amount of association attached to it. We're now trying to design across exhibits and to standardize materials a bit for consistency, so that we can focus more attention on the core experiences offered by exhibits by reducing distraction through competing and different design elements. Our exhibition designer and developers work closely to come up with an exhibit that is conceptually as well as visually coherent. But whatever the end result, we don't know what it will actually mean to people. Or even what it will look like to them. (To me, the Give and Take Table looks a bit like a drinking fountain.)

And that will have some effect on how people use it, but we're not set up to figure out that effect. Although we have imagined doing a comparison study that might involve making one table out of an old vanity and one out of shiny new steel, putting them next to each other on the floor and seeing what happens. Or trying one out one week and the other another week—perhaps the vanity table would encourage people to share left and right, but the steel table would inhibit them.

So, part of the answer is we don't really know the effect of the design on behavior.

PRJ: In my experience, the meaning embedded in a design definitely affects participation. As part of one of my works people were supposed to put money in a cup. So I performed different experiments to see what would happen if the cup was placed at different heights, like the height that a person would hold the cup when begging for money, for example. I don't think people saw that height and consciously related to it as I intended, but it did affect them in a different way than if I had placed the cup on the floor.

I'm always struggling to figure out if there is more meaning to be infused through these design elements or through an overt narrative like a shipwreck. These variables affect people's behavior tremendously and it seems that is an even more compounded problem for you.



Well, 2008.
Pedestal, water,
paper coffee cup,
silent wish and coin
provided by the
public. Installed
at the Aldrich
Contemporary
Art Museum,
Ridgefield, CT

HM: Absolutely. Some variables are identified in team discussions early on and others you don't discover until later. Often we design a bunch of exhibits, and then at the very last stage of the project we bring them all together and design the exhibition envelope that holds them—the walls, look, and feel. It's not necessarily the best way to go about it because you're lacking a really important piece of context setting until you get to the very end and by then you don't have as much money or time left, but the exhibit design necessarily comes first. We don't really know what the design envelope will say to people about how they should behave. And, in fact, we have a lot of discussions about whether that's even a goal. What if the exhibition is telling you how you should behave? Is that a good thing or a bad thing?

Some team members want to actively promote sharing, because that seems to be a "better" kind of behavior, but we can't give people commands. They don't respond well to them, and they don't



Well, 2008 (detail)

learn anything about themselves other than that they don't like you anymore. If people don't want to share, then it's more interesting that they become aware of that, since then they've learned something about themselves.

It reminds me of another exhibit that's now on the floor—Donation with Contemplation—have you seen that?

PRJ: You told me you were planning it, but I haven't seen it in effect yet.

HM: It's very simple—a table with three Plexiglas tubes, and the name and a short description of a charity attached to each tube. We chose the three charities fairly arbitrarily so that we would have very different kinds of opportunities to share. There's the SPCA (the animal benefit organization), there's Greenpeace, and there's a local arts institution in the Mission District. The signage encourages visitors to give to whichever charity they prefer, or to feel free not to

give, but if they're giving, to also think about how they make their choice. How does one decide which one to give to?

PRJ: That's the difficult part.

HM: It was fascinating. First of all, people really do give, and they give a lot. And there's a very clear winner among those three charities. Care to guess?

PRJ: I'd say the animals.

HM: Absolutely. By two to one.

PRJ: Wow.

HM: We've asked people what they think this exhibit is about and how they make their choice, and we've had a great range of responses ranging from "animals are not responsible for their fate," to "humans make evil choices and animals don't." Or, "I saw that one charity was getting a lot less than the others, so I donated to that one." And conversely, "I picked the one that had all the money in it because I thought that must be the best charity." The responses were very candid.

PRJ: But don't you think there's also something about that exhibit that traces a history? So even if you don't participate, you can at least see a trace of other people's participation. You can be an "armchair" participant, even if you're too self-conscious to participate. A voyeur of sorts.

HM: Absolutely.

PRJ: I think the hardest thing is creating that moment you mentioned when people become self-aware. It's not about telling people sharing is good or bad, but it's about making people self-aware in that moment of decision-making.

HM: Right. So how do you think your pieces, and this one in particular, create a kind of self-awareness? What were the thoughts that went into the design of *We Make the Treasure* to generate that self-awareness?

PRJ: Well, I had already made a past work in which everything is geared towards one point of exchange. You had to go through a number of steps until you made a decision to participate or not participate, exchange or not exchange. There was a singular moment framing the work.

But because *We Make the Treasure* is situated on the street and there are so many people passing by, plus it's accessible from 360 degrees, seven days a week, 24 hours a day, I wondered what would happen if you could engage with it in multiple ways? So that there's no clear idea of when participation begins or has come to an end; a little bit like a playground where many different things can happen.

As for the self-consciousness, it is the part that still makes me nervous because there's no way for me to know if that has happened. There's nothing in the participants' bodies or movements or how they handle the materials that reveals that that has happened. I can see if people have left coins or taken them. We can all see that. But what's happening inside people's heads remains unseen. I don't know if that answers your question.

HM: You raise something that I think is an interesting difference between the free world outside and the paying world inside, and the context provided merely by being in a museum. You said that one of your design goals was that many things could happen with and through your work.

PRJ: Right.

HM: When we make exhibits we have to, on the one hand, provide an opportunity for people to use them in different ways, but on the other hand, ensure that they are easy to access. Very commonly, when people say they didn't like an exhibit, or were frustrated by it, they actually mean they didn't know what they were supposed to do, right?

PRJ: Yeah.

HM: "I didn't know," or, "I couldn't tell how I was supposed to use it and so I just didn't use it at all." We often make an exhibit that could be used in a bunch of different ways only for people to say, "I didn't want to use it because I didn't like the idea that I had to



We Make the Treasure
installation
overview

choose which way to use it.” We certainly heard that about the Give and Take Table. “It’s confusing because you’re letting me make the choice, and I just paid \$25 admission for you to tell me how things work.” It’s harder to make the point that they actually paid admission to find out how things work, not for us to instruct them.

When people haven’t paid, when they don’t have the expectation of enlightenment, they might think, “it’s up to me to engage, or figure this out.” Outside the institution they’re enabled to try a whole bunch of different things.

PRJ: Does one bite the bullet and think that if one in every hundred visitors participates, that’s plenty? How many participants are enough? What percentage of the public has to come, be willing to participate and then be satisfied? I have certain pressures because making art brushes up against entertainment, and I assume you have certain pressures as well.

HM: We have an ongoing conversation about that, both internally and externally. And I try to make the case that we probably have to be okay with a relatively lower number of users for these exhibits because they ask more of visitors than physical phenomenon exhibits, like the one that asks you to make a pendulum swing.

I don't know what the numbers are, but I don't feel the answer is to keep tweaking the exhibit until everybody, or the majority, does what it is you wanted because then you've taken the interesting part out of the process. But it is a discussion that we have both with our internal evaluation staff and with external evaluators like the National Science Foundation, which funds a lot of our projects.

PRJ: I was thinking about scalability and intimacy. A painting is designed for an individual, one-to-one exchange, right? It's a pretty intimate encounter.

But when I went to the Museum of Modern Art in New York and tried to look at a Van Gogh painting recently, the number of people there doing the same thing negated the exchange that the work was designed for.

HM: We've definitely run into that kind of problem. When we set up an exhibit in an artificial, testing environment it might produce a great conversation, but in an unmediated environment, where access is not controlled, you've eliminated the possibility of having a conversation because of the way the context functions.

PRJ: Right.

HM: I've often felt that we set the bar for engaging with an exhibit very low. If an exhibit doesn't give you immediate gratification, there's another one right over there that might.

In some ways, that's a real challenge for these exhibits. They only work if you do have some feelings and thoughts, and you maybe talk to somebody else and say, "Well, that's weird, what did you get out of it? That's not what I got out of it." And yet we make that really hard for visitors to do.

Your piece outside actually has a greater chance of success than the average Science of Sharing exhibit because its setting promotes taking time. It's rich, it's complicated, it's got a narrative. You don't



*We Make the
Treasure in use*

look at it and say, well, I can experience this in five seconds. And if I can't do it in five seconds, there's something else five feet away that I can do in five seconds.

PRJ: Right. Although I am competing with the pull of the seaports.

HM: The ultimate goal would be to connect these micro-experiences with larger real-world experiences. So that squirting water at people at the Trust Fountain³, reminds you of something you saw on the news the other day about mistrust between nations leading to defensive behavior. I would argue every exhibit here is an exhibit about how people think, and maybe to some extent how they feel, and how they perceive the world.

The difference is that we always regard social interaction as a nice side benefit, but don't really design the exhibit to be about that, so probably the single biggest challenge we still face is getting strangers to interact.



The Commons,
2011. Cork,
push pins, notes
provided by the
public. Installed
at Pinacoteca do
Estado de São
Paulo, Brazil

People have a tendency to hang out with people who are like them. But you don't necessarily learn an awful lot about human nature in general when you spend all your time with the same people or people who are just like you. The real learning happens when you discover that somebody saw the exact same social interaction totally differently than you did. That's real trust, right? That's what we want, and that's a high bar.

PRJ: The stranger is important. I read a lot about what a public actually is or does, and some thinkers argue that a public has to be constituted by strangers—if it just involves you and your friends, or family or tribe, it does not really count as a public situation. Public situations are really interactions between strangers.

HM: Right. Maybe there is no such thing as a strategy if you're going to make a place like this?

PRJ: I believe that the forms we need are out there. When I go to a public basketball court in New York and there's a pick-up game, people inherently know how to participate. Strangers play with each other. They wait their turn for one game to end and another to start. The rules are very clear.

What are the details in this forum, the pick-up basketball game at the public basketball court, that make all the things we're talking about happen seamlessly?

HM: This brings up the distinction between "free choice" and "free." If there's a free tennis court or a free basketball court, there's a different set of expectations about usage and ownership and sharing, and there's a kind of onus put on you as a user to enforce rules or participate in enforcing rules that there isn't when you pay to be part of a context.

PRJ: The tragedy is that in English, the words free and freedom are the same, right? The free university here would mean students don't have to pay. But in Germany, no one has to pay for university. Free university in that context means that the university has freedom. I'm fascinated that the two words are conflated in English.

HM: Does your work for the Exploratorium build on your own body of work as an artist or the history of public art more generally? How would you describe it and what informs it?

PRJ: I've always been interested in monuments, which are made for a public and for public situations, versus artworks that are sometimes publicly and sometimes privately shown. So, I always like to think of the monument as a subset of art-making that tells shared stories.

There are very few public monuments to private deeds. Usually they commemorate battles, or public figures and so on. I like the fact that the text of the monument is already shared. I also like that it's susceptible to unforeseen use through its public context. A monument to a battle can be used by joggers to stretch their legs before they go for a run, and the further away it gets from the events that it's commemorating, the more the uses that are invented for it.

Monuments are social objects that remain social even after the story that they're telling is no longer of any interest.

The other thing that I'm interested in is art as a public activity, and how the public constitutes itself around the art object. It's a momentary gathering, right? And it has the quality of a true public because there's no precondition of membership or identity. People are just there. They are interested in this type of work and so they congregate around it.

Those are some things I'm interested in. All my early work had to do with embodying natural phenomena in objects and then I shifted to embodying social phenomena in objects. This is what I'm still exploring now.

HM: What you said made me think of a recent article in the *New Yorker* about the World Trade Center monument, which I'm sure you have done a lot of thinking about.

PRJ: Well, it's interesting how quickly after 9/11 the anxiety that arises every time there's a national tragedy manifested itself—the fear that we will forget—followed by the declaration that we will never forget. But just in case, let's put a great amount of effort into making a permanent marker of the thing we're trying to remember.

HM: Right.

PRJ: And I can bet you any amount of money—and I can because we'll both be dead—that the 9/11 memorial will mean something very different to people who visit that site in 100 years. It will certainly not mean what we intended, or what it means to us.

HM: I imagine that what would currently be seen as offensive and sacrilegious behavior, like having a picnic there, will not be problematic in 100 years.

PRJ: Right. And that is what's happening now at the 9/11 memorial. Sometimes people will yell, trying to discipline someone taking a selfie or a smiling picture. It's not happening by any authority. It's just the visitors themselves trying to hash out an argument about what's appropriate behavior, or not, among themselves.

HM: I suspect where we come together is that we both think that self-policing and self-rule-generating, or spontaneous rule-generating, are what's really interesting.

PRJ: Yes. The ideal artwork creates a situation where that happens. And where people are aware that that's what they are doing. But as we both know, that's difficult.

Can I have a job as your exhibition designer?

HM: Absolutely.

1 The Give and Take Table is a new exhibit at which visitors can take an item but are asked to replace it with something of equal or greater value. It is inspired by the "tragedy of the commons," a situation in which all members of a community play a role in maintaining a shared resource. For further discussion of both the Table and the Commons, please see Nato Thompson's essay on pp 11–23.

2 Significantly, Exploratorium staff recently observed a visitor to Ramírez Jonas' work connecting *We Make the Treasure* to the Science of Sharing exhibit Text Fish in the Exploratorium's West Gallery, which is based on the tragedy of the commons. At that exhibit, visitors use their cellphones to catch virtual fish from a simulated ocean. Visitors can catch as many as they like, but unless they coordinate their behavior, they'll overfish and destroy the resource.

3 At the Trust Fountain exhibit players can choose whether to give their partner a drink or a squirt of water in the face. The Trust Fountain is based on the Prisoner's Dilemma, a situation in which two people decide whether to cooperate or compete with each other without knowing what the other will do. Mutual cooperation leads to the best outcomes for both. But if they cooperate they leave themselves open to exploitation by their partner so people often compete, although this often results in less beneficial outcomes for both of them.

WE MAKE THE TREASURE: THEMES AND REFERENCES

Marina McDougall



Newspaper boys cool off in a New York City park fountain, 1916

CIVIC ART

Paul Ramírez Jonas' projects could be considered as propositions for how civic art might be re-imagined to better serve the public perhaps even in very practical ways.

Public statuary was initially conceived to remember specific battles, cultural heroes, or significant dates. In addition to this commemorative function some monuments incorporated practical design elements, such as seating, for instance.

While most memorials were imposing, large-scale structures made of seemingly permanent materials such as bronze, marble, or stone, other public statuary incorporated urban infrastructure thereby monumentalizing civic achievement. Ramírez Jonas considers these kinds of civic works as "public art." Like the ornate clocks that once

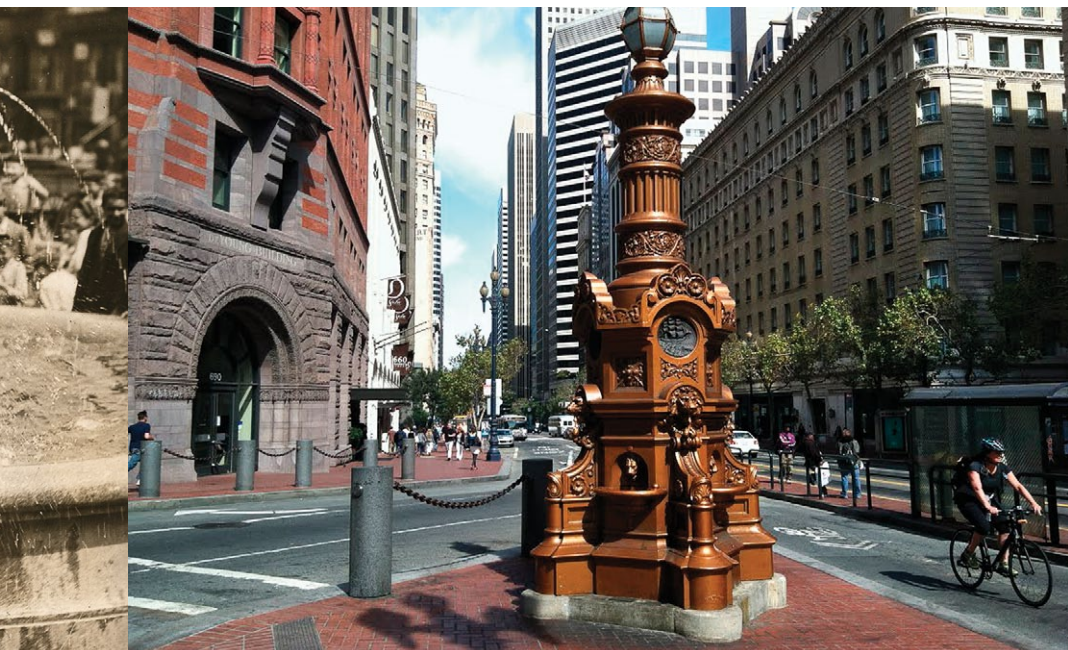

Lotta's Fountain, San Francisco

enabled citizens to keep time, for example, or the decorative lamp-posts that lined urban streets.

A curious blending of the civic, functional, and monumental is found in some forms of early water infrastructure. Before the advent of indoor plumbing at the end of the 19th century, public fountains provided water for drinking, cooking, washing, and bathing to most urban communities.

This is why one of San Francisco's most beloved public sculptures, Lotta's Fountain, was originally designed with tin cups chained to its basins. Donated to the city in 1895 by Lotta Crabtree, a Gold Rush vaudeville performer, the Fountain still stands on a traffic triangle at the intersection of Geary, Market, and Kearny Streets. However, successive renovations over the decades have rendered the gilded fountain purely decorative and today its spigots run dry.



Lotta's Fountain, San Francisco, 1960

Ramírez Jonas' *We Make the Treasure* incorporates a flow of water from Bay to bucket over barrel and into boat, as a kind of "fountain" element. The work's sculptural components, e.g. the barrels and pennies, maintain aspects of their original functionality, but are given new resonance through historic (i.e. San Francisco's maritime past) and conceptual explorations (i.e. how can an artwork further public reflection on notions of the commons?).¹ By melding functional, symbolic, and conceptual elements, Ramírez Jonas proposes a new kind of public art.

Perhaps, therefore, Ramírez Jonas' work can be understood as "conceptual functionalism," a term that artist and architect Maya Lin uses to describe her evolved notion of a monument. A good illustration of this genre is Lin's project *Confluence*, a series of art installations positioned along the Columbia River in Oregon and Washington states. The project combines functional aspects (natural



Abandoned ships in the San Francisco Bay, 1849

habitat restoration) with historical narrative (the evocation of Lewis and Clarke's journey and Native American histories) and conceptual investigations (how can we re-imagine a monument? What is a public park?). In combination these conversations advance cultural dialogues and model positive social change in public space, creating an active form of commemoration.

SAN FRANCISCO'S SUNKEN AND ABANDONED SHIPS

The San Francisco Bay is littered with hundreds of sunken ships that were run ashore by powerful currents and poor visibility due to fog, or wrecked on jagged reefs. On particularly low tides the ghostly outlines of submerged vessels can be seen from Ocean Beach and along the cliffs of Land's End. These shipwrecks are reminders of the

WE MAKE THE TREASURE: THEMES AND REFERENCES



The *Frank E. Jones*, shipwrecked in 1877, San Francisco

city's history as a port and center of global maritime trade. In *We Make the Treasure* the outlines of one such ship, the *Beeswing*, a two-masted schooner that sank near the Farallon Islands in 1863, are “sketched” in the water by submerged lines pumping air bubbles to the surface in an area of the Bay between Piers 15 and 17.

San Francisco's Gold Rush reached its frenzied height between the spring of 1849 and fall 1850. During this time, almost a hundred thousand people came to the city to seek their fortune in gold. While some (approximately 23,000) arrived over land, the majority (around 62,000) travelled by water. Virtually all of the vessels, about 550 in total, that entered the Bay during this time were abandoned. Their crews and passengers headed to gold country leaving the ships to rot in their moorings. A famous photo of the downtown waterfront from this time pictures the scene as “a forest of masts.”



The shipwrecked (1878) remains of the clipper *King Philip* at Ocean Beach, San Francisco

Soon after the ships were abandoned, a rapidly expanding city covered them over with landfill. While conducting research for his *Over the Water* commission, Ramírez Jonas was captivated by maritime archeologist James Delgado's² accounts of San Francisco's history of abandoned ships. *We Make the Treasure* is located near eight maritime archeological excavation sites along the Embarcadero.

LOST & FOUND

Popular lore imbues sunken ships with an aura of mystery and the promise of treasure—gold coins, Roman amphorae and statuary, rare Asian ceramics, and more.

Ramírez Jonas is fascinated by how the disparate elements of a seafaring vessel's cargo loaded from a variety of sources combine

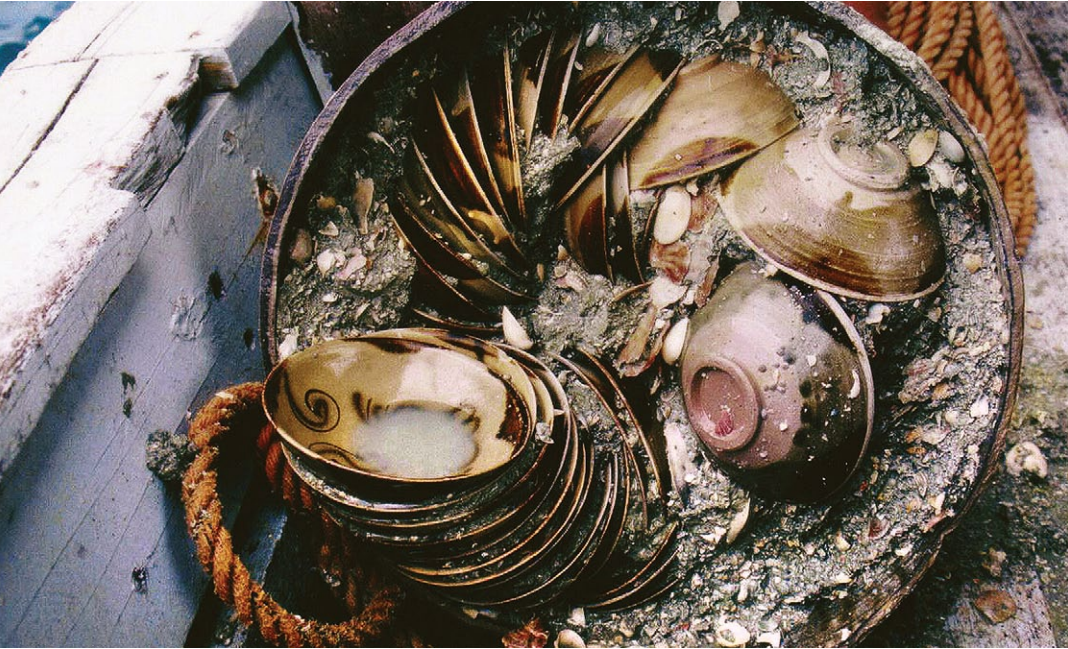

Tang Dynasty (618–907 C.E.) Chinese ceramics excavated from shipwreck off the coast of Belitung Island, Indonesia

arbitrarily, and become part of a shared narrative through a ship's wreckage. There is no record of what the *Beeswing*, the schooner that inspired *We Make the Treasure*, was carrying as cargo when it was bound for Monterey that fateful day in 1863. Caught in gale force winds off the San Francisco Bar, near the Farallon Islands, the schooner sank. Its flotsam was later recorded as cases and cans of oil and camphene and boxes of candles by passengers on a passing vessel who witnessed its sinking. On its previous voyage the *Beeswing* had carried items including: 40 steer hides, four boxes of cheese, 120 trees, and a stack of logs.

The salt-encrusted, oxidized green and white patinated pennies featured in *We Make the Treasure* build upon our fascination with things lost and found above and below the water line.



Cowrie shell currency

CURRENCY

We Make the Treasure is designed to place penny-sized objects made out of different materials, and with different potential uses, symbolic meanings, and exchange values in our hands. In the process of handling these coins, their perceived value subtly begins to shift as we consider them from various perspectives (such as their material worth versus their monetary value, or how they are used as talismans).

Throughout history a wide variety of materials have been used as currency. While some are useful in and of themselves, others, such as beads, feathers, ivory, cowrie shells, and obsidian, have been prized more for their aesthetic appeal. Every form of currency circulates within limited boundaries due to the social understandings that have been established to reinforce its value.



Stone currency from the Yap Islands, Micronesia

One of the most remarkable forms of currency is the Rai, stone money introduced in the Yap Islands of Micronesia sometime between 500 and 1000 C.E. and still in use today. Rai are carved circular stone discs with holes carved in their centers. The largest Rai measures as much as twelve feet across, is one and a half feet deep, and weighs nearly 9,000 pounds. The smallest are comparable in size to a dollar coin. There is no limestone to be found on Yap, and so the stones brought to the island from the quarries of Palau remain prized for their rarity. The holes in the center of the Rai allow for the discs to be strung on ropes or on wooden staffs, which makes them easier to transport. Individual Rai derive their value from an oral history of ownership, and this value is proportionate to the richness of the history. How many people died during the treacherous journey from Palau? Was the central hole fashioned by hand using a shell tool or



Yapese home with stone currency indicating great wealth, 1971

carved with a more modern one? Was the stone dedicated to a chief who sponsored the trip to Palau?³ Stone money has been used in Yap to further political alliances, purchase land, and even secure wives. Because the stones are generally very large, they are not usually moved once they arrive from Palau, or physically exchanged when ownership is transferred from one person to another.

LEWIS HYDE

Cultural critic Lewis Hyde is the author of two remarkable books that have inspired Paul Ramírez Jonas: *The Gift: Imagination and the Erotic Life of Property* and *Common as Air: Revolution, Art and Ownership*.

In both books Hyde shows how art plays a mysterious and transformative role in mediating the different logics of market and gift

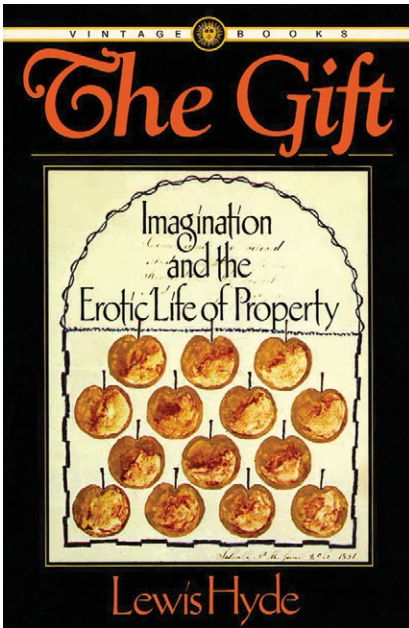

economies, private property, and the commons. *Common as Air* traces the shifting boundaries between what is public and what is private, surveying a trajectory from the coopting of forests as royal hunting grounds to the rise of intellectual property rights.

The Gift reflects further upon the history of gift exchange in anthropology and folklore, especially as related to works of art, in order to illuminate the complex underlying social contracts implicated in such exchanges. Hyde's argument emphasizes the need for gifts to remain in circulation in order for the social order that surrounds them to be maintained.

In one example Hyde describes rituals of Pacific tribes of the North Pacific Coast of the U.S., who have “developed

a relationship to the natural abundance of their environment based upon a cycle of gifts.”⁴ Understanding this abundance as a gift, and salmon as underwater humans, the tribes engage in an annual spring ceremony to honor the first of these fish to swim upriver to spawn. In this ritual, a priest or his assistant catches and kills the fish, and “parades it to an altar...as if it were high ranking chief from a neighboring tribe.”⁵ After the priest sprinkles its body with eagle down or red ochre, gives a formal welcoming speech, and politely expresses the hope for continued abundance, celebrants sing songs to honor the visiting guest and receive a piece of the fish to eat. After this, the remaining intact fish skeleton is returned to the river (with the idea that the salmon will reconstitute itself, swim to its underwater home, and revert to its human form). Through this ceremony participants acknowledge their dependence upon nature's generosity, their place within natural cycles, and their own role in maintaining balanced ecologies.

Hyde's influence on Ramírez Jonas can be seen in works by the artist that generate reflection upon the complex value systems and social psychology that surround exchange.

According to Ramírez Jonas, "to understand what can be transformed, it is helpful to not see things as static. Lewis' book on what is and isn't common property helped me see that."⁶ The artist quotes the playwright Bertolt Brecht to further elucidate his meaning: "The present-day world can only be described to present day people if it is described as capable of transformation."

1 "Commons" refers to the natural or cultural resources, from air and water to software and ideas, accessible to all members of a society. The term originates from the German legal term *Allgemein* referring to land open to common usage through activities such as hunting, fishing, or the grazing of sheep. A commons can be owned collectively or by a single person and can include both shared and private property. When a commons is transformed into private property the terms "enclosure" or "privatization" are used to describe the process.

2 James Delgado, *Gold Rush Port: The Maritime Archeology of San Francisco's Waterfront* (Berkeley and Los Angeles: University of California Press, 2009), 114.

3 http://news.bbc.co.uk/1/hi/english/static/road_to_riches/prog2/tharngan.stm

4 Lewis Hyde, *The Gift: Imagination and the Erotic Life of Property*, (New York: First Vintage Books, 1979), 26.

5 *Ibid.*, 26.

6 Paul Ramírez Jonas in e-mail correspondence with the author September 29, 2014.

Marina McDougall is Director of the Exploratorium's Center for Art & Inquiry, a research and development laboratory for the arts within the larger learning laboratory of the Exploratorium. A curator working at the intersections of art, science, nature, and culture, McDougall has twenty years experience organizing exhibitions and public programs. McDougall was the first Curator of Art and Design at the CCA Wattis Institute for Contemporary Art and is a co-founder of the Studio for Urban Projects. She has been a visiting curator at the MIT Media Lab, the Museum of Jurassic Technology, the California Academy of Sciences, and the Oakland Museum of California. McDougall is an Adjunct Professor in the Graduate Program in Curatorial Practice at California College of the Arts.

Paul Ramírez Jonas
on site, 2014



PAUL RAMÍREZ JONAS BIOGRAPHY

Paul Ramírez Jonas was born in Pomona, California in 1965, and raised in Honduras. Educated at Brown University (BA, 1987) and Rhode Island School of Design (MFA, 1989), Ramírez Jonas currently lives, works, and teaches in New York City.

Over the last twenty-five years Ramírez Jonas has created works that range from large-scale public installations and monumental sculptures to intimate drawings, performances, and videos. Through his practice he seeks to challenge the definitions of art and the public, and to engineer active audience participation and exchange. His 2010 Creative Time project *Key to the City*, for example, involved 25,000 participants and centered around a key as a vehicle for exploring social contracts pertaining to trust, access, and belonging. Keys have featured repeatedly in his work as symbols of access and exclusion, public and private ownership. Coins also are a recurring motif allowing the artist to question notions of value, circulation, and societal rituals or behaviors.

In addition to conceiving public projects, both permanent (e.g. *Taylor Square*, Cambridge Mass, 2005–) and temporary (e.g. *Talisman*, 28th São Paulo Biennial, 2008), Ramírez Jonas has been the subject of numerous solo exhibitions at venues including the Aldrich Contemporary Art Museum, Ridgefield, Connecticut (2008); the Jack S. Blanton Museum of Art, Austin, Texas (2007); and the Ikon Gallery, Birmingham, UK (2004). His work has also been presented in major group exhibitions, such as most recently *Under the Same Sun*, Solomon R. Guggenheim Museum, New York (2014) and *Residue of Memory*, Aspen Art Museum (2012), as well as at biennales in the cities of Porto Alegre (2009), Venice (2009), Shanghai (2006), Seoul (2000), and Johannesburg (1995).

For his Exploratorium commission, Ramírez Jonas traveled to San Francisco repeatedly over a one-year period to research the city's maritime history and work closely with Exploratorium staff on the development of the project.

WE MAKE THE TREASURE PROJECT TEAM

PAUL RAMÍREZ JONAS STUDIO

Nathan Carey
Indra Ramírez Antoni
Erich Richter
Aida Šehovič
Kristof Wickman

EXPLORATORIUM OVER THE WATER PROJECT TEAM

Kirstin Bach
*Program Manager,
Center for Art & Inquiry*

Eileen Campbell
Senior Science Writer

Eric Dimond
Director of Exhibit Development

Adam Esposito
*Design Engineer,
Studio for Public Spaces*

Steve Gennrich
*Project Director,
Studio for Public Spaces*

Donna Linden
*Editorial/Graphics Production
Manager*

Jesse Marsh
*Design Engineer,
Studio for Public Spaces*

Herb Masters
Volunteer

Marina McDougall
Director, Center for Art & Inquiry

Phanna Phay
High School Explainer Supervisor

Susan Pomon
Senior Graphic Designer

Keana Raven
Exhibit Maintenance Explainer

Robert Semper, Ph.D.
*Associate Executive Director,
Director of Laboratory*

Jordan Stein
*Assistant Curator,
Center for Art & Inquiry*

Peter Taylor
Exhibit Technician

Jacky Witstok
Exhibit Maintenance Explainer

PROJECT CONSULTANTS

Gina Bardi
*Reference Librarian,
San Francisco Maritime
National Historical Park*

John Borruso
catalog designer

James P. Delgado, Ph.D.
*Director, Maritime Heritage
Program, U.S. National Oceanic
and Atmospheric Administration,
Office of National Marine
Sanctuaries*

Richard Everett
*Exhibits Curator, San Francisco
Maritime National Historical Park*

Aaron Gach
Center for Tactical Magic

Shannon Jackson, Ph.D.
*catalog contributor/Richard and
Rhoda Goldman Chair in the
Arts and Humanities, Professor
of Rhetoric and of Theater,
Dance and Performance Studies,
Director of the Arts Research
Center, University of California
Berkeley*

Leigh Markopoulos
*catalog managing editor/Chair
Curatorial Practice MA Program,
California College of the Arts/
Center for Art & Inquiry Advisor*

Hugh E. McDonald, Ph.D.
*catalog contributor/
Exploratorium Project Director,
Senior Science Writer and
Associate Curator*

David Mik
Power Engineering Contractors, Inc.

Nato Thompson
*catalog contributor and
advising curator/Chief Curator,
Creative Time*

EXPLORATORIUM PROJECT CONTRIBUTORS

Sylvia Algire
*Acting Associate Director School
Field Trip Explainer Program*

Dennis Bartels, Ph.D.
Executive Director

Sal Bell Alper
Field Trip Explainer Program

Jackie Clay
Online Social Engagement

Liana Crouch
*High School Explainers
Associate Director*

Michelle Gurman
*Administrative Director,
Laboratory*

Dave Johnson
Production Manager

Liz Keim
*Director of Cinema Arts,
Senior Curator*

Alice Krasinski
Director of Public Space

Shani Krevsky
*Project Director,
Exploratorium Campus*

Gayle Laird
Photographer

Shawn Lani
*Studio Director,
Studio for Public Spaces*

Kristina Larsen
Senior Project Manager

Susan Schwartzberg
*Senior Artist,
Bay Observatory Curator*

Jenny Slaf osky
Communications Manager

Amy Snyder
Senior Photographer

Charles Thomsen
High School Explainer Supervisor

Phoebe Tooke
Senior Videographer

Pam Winfrey
Senior Artist and Curator

ABOUT THE EXPLORATORIUM

The Exploratorium is an interactive museum dedicated to science, art, and human perception. A global leader in informal learning, it has developed creative exhibits, teaching tools, programs, and experiences that ignite curiosity since 1969. In 2013, the museum moved from its original home at the Palace of Fine Arts to a LEED Platinum–certified new building at Pier 15, along San Francisco’s revitalized Embarcadero. In addition to the 600-plus exhibits that inhabit its six galleries, the Exploratorium transcends its own walls via its teacher professional development programs; its relationships with the National Oceanographic and Atmospheric Administration, NASA, and other governmental, educational, and corporate partners; and its collaborations with science centers around the globe.

CENTER FOR ART AND INQUIRY

The Center for Art & Inquiry (CAI) serves as an R&D center for the arts within the larger learning laboratory of the Exploratorium. CAI leads the Exploratorium’s arts strategy and direction, expanding the museum’s focus on art as a medium for exploration, inquiry, and discovery. Working with program directors from across the museum as well as a council of national advisors, CAI oversees the museum’s long-running Artist-in-Residence Program, hosts research fellows, and initiates special projects to advance work at the intersection of art and interdisciplinary learning.



“Paul Ramírez Jonas is an artist who questions the very notion of “public” by making works that touch us individually. In *We Make the Treasure* he uncovers histories, invokes a ghost ship, and engages us in simple actions that become meaningful reflections about the small everyday treasures that we often overlook.”

—Pablo Helguera

expl  ratorium®

\$10.95
ISBN 978-0-943451-75-6
5 1095 >



9 780943 451756