

T

M

B

米九  
木十

**MOD001.IKI**

Modular

System

米丸  
木舟



**ATELIER DE CRÉATION GESTE.S**  
**THE LEARNING OF GESTURE EXPRESSION**

*Geste.s*: Noun, archaic, the manner in which one conducts oneself; also something one offers to another.

L' Atelier de Création Geste.s is an interdisciplinary design platform built on a deep respect and love for raw materials and artisanalcraft. We seek to work across multiple scales to create spaces, furniture and objects that are sincere,authentic, frugal, straightforward and inherently alive.

Craft is crucial: we build durable bonds with the craftspeople with whom we work, and believe that a project, regardless of its scale, must be from the very start an iterative back-and forth between those who make and those who design.

Our emphasis on craft is accompanied by deep reflection on the choice and qualities of materials.

- Where (and how) are they sourced and what meaning do they hold in their local region, community and culture?
- What are their intrinsic properties, and thus what design potential do they offer?
- Most importantly, how can we capture their natural essence and apply it in our projects, while meeting clients' needs for use and care ?

Our pledge to clients – our “geste” – is to strive to unite design, materials and craft to create work that is unique, honest, ecologically sustainable and timeless, without detours or concessions.

MOB001.B Kasagi, Studio Shots with Juliette Lambert  
Photo : Cécile Bortoletti ©





**MOD001.IKI**

Système Modulable

**UNE COLLECTION MODULAIRE ET ÉVOLUTIVE, AU SERVICE DES USAGES**

"MOD001 Iki" is a series of elements that can be used to create a multitude of modules, ranging from a simple stool to a larger set of exhibition trays for scenographic purposes.

Far from a single object fixed in its form, this collection is evolving, versatile and plural.

A direct descendant of the Atelier's first collection, "La Taulo e l'Oustau", presented at the Collectible show last March, "MOD001 Iki" retains its structural and conceptual essence, while opening up a wider range of possibilities. The elements that make up this collection include 2 leg heights, 3 crossbar lengths and 1 top size in a multitude of finishes and an infinite diversity of solutions.

*"The object evolves at the same time as the uses it seeks to satisfy. A stool can become a bench by changing two crosspieces, a pedestal table can become a console by replacing its legs, and a scenographic ensemble can be reassembled, expanded and adapted to new configurations. The possibilities for MOD001 Iki are endless," says Thomas Morineau Barthélémy.*

"MOD001 Iki" is aimed at both private individuals looking for unique furniture (seats, consoles, coffee tables, pedestal tables) and set designers looking for a system that can be adapted to the needs of a showcase or exhibition.

The many combinations offered by this collection meet the needs of everything from the most everyday to the most artistic.

Right Page : "MOD001.Iki", module 1x1 Haut, module 1x3 Bas  
Photo : Geste.s ©





## MOD001.IKI

Modular System

### IKI INSPIRATION

*Iki* (粋) is a Japanese aesthetic notion that defines an ideal of natural sophistication, emphasising a certain detachment, singular elegance and the charm of discretion.

Its concept is based on three fundamental pillars:

- **Simplicity and Purity:** Iki values the absence of excessive ornamentation, finding beauty in the purity and simplicity of forms and actions.
- **Discretion and Restraint:** The Iki aesthetic implies restraint and an absence of pretension, valuing subtlety and modesty.
- **Self-confidence and Naturalness :** "Iki" objects have a natural assurance, not following trends or fashions, but possessing a quiet confidence.

*"MOD001 Iki formalises a concept dear to the Atelier: the essential structural sincerity and the necessary frugality of means in the service of an authentic, living, repairable object with virtually zero environmental impact. Iki (粋) is at the heart of our approach,"* adds the founder of Atelier Geste.s.

### PROSPECTS AND COLLABORATIONS

Through the Atelier de création Geste.s, Thomas Morineau Barthelemy will be inviting artists and craftspeople to collaborate on finishes, textures, materials, formats, combinations, uses and colours, in order to take advantage of the versatility offered by the "MOD001 Iki" modular system.

The collection is destined to expand, bringing with it new uses and surprising collaborations as it spreads.

*"MOD001.Iki is a creative device that is destined to grow and develop through a variety of collaborations. This is the very essence of l'Atelier: to evolve in contact with traditional know-how and to create a meeting point between design and production. MOD001.Iki is the manifesto for this and the basis for future collaborations,"* concludes Thomas Morineau Barthélémy.

The continuation of "MOD001.Iki" will be shaped through collaboration, much like the Atelier de Création and its working process with clients, following a sensitive, ecological, and honest approach to create a flourishing experience

*Right Page : The essence of Iki, photo : Kusakabe Kinbei*





**MOD001.IKI**

Modular System, Evolutive and Versatile

Simple Beam - 420 x 80 x 20mm	①
Natural stained Ash	
Double Beam- 720 x 80 x 20mm	②
Natural stained Ash	
Triple Beam- 1020 x 80 x 20mm	③
Natural stained Ash	
Square - 300 x 300mm	④
Natural stained Ash	
Small Leg - 440 x ø75mm	⑤
Natural stained Plane Tree	
High Leg - 640 x ø75mm	⑥
Natural stained Ash	
High Leg Assembly	⑦
Assembly System of MOD001.Iki	
Small Leg Assembly	⑧
Assembly System of MOD001.Iki	

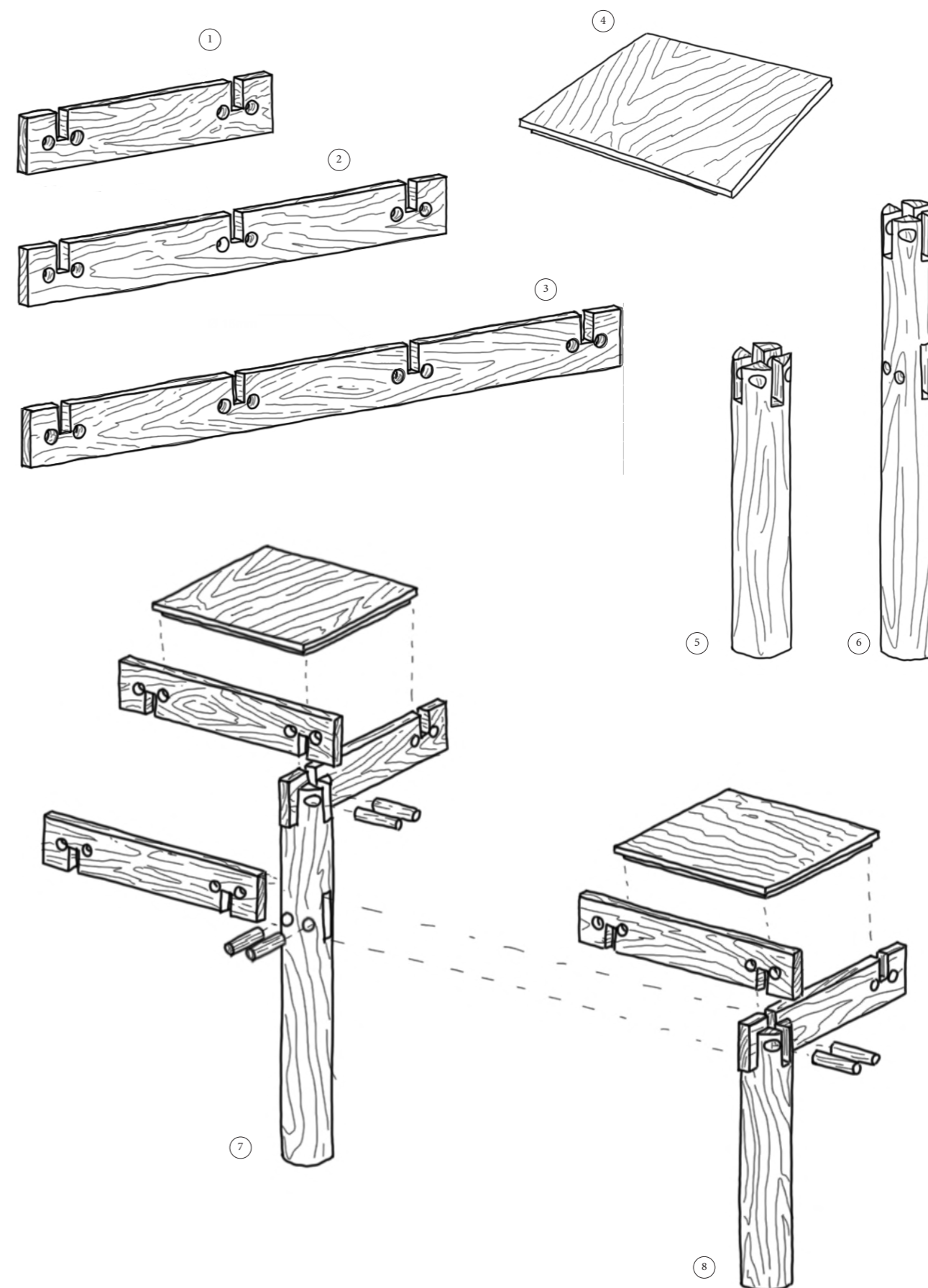

Next Page : The very large range of MOD001.Iki, Illustrations : Juliette Lambert ©







**MODULE SIMPLE BAS - 1X1B**

Dimensions : H470 x L420 x L420mm  
Usage : Stool, Side Table, Exhibition Stele  
Bespoke finish upon request



MOD001, module simple 1x1 bas, Studio Shot  
Photo : Geste.s ©



MOD001, module simple 1x1 bas, Studio shot  
Photo : Geste.s ©





MOD001, module simple 1x1 bas  
Photo : Geste.s ©



MOD001, module simple 1x1 bas, Assembly Detail  
Photo : Geste.s ©





MOD001, Assembly Detail  
Photo : Geste.s ©



**DOSSIER DE COLLECTION**

**MODULE TRIPLE BAS - 1X3B**

Dimensions : H470 x l420 x L1020mm

Usage : Bench, Double Stool, Coffee Table

Bespoke finish upon request



*MOD001, module simple 1x3 bas, Studio shot*  
Photo : Geste.s ©



*MOD001, module simple 1x3 bas, Studio shot*  
Photo : Geste.s ©





MOD001, module triple 1x3 bas  
Photo : Geste.s ©



MOD001, module simple 1x1 bas, Assembly Detail  
Photo : Geste.s ©



**MODULE SIMPLE HAUT - 1X1H**

Dimensions : H670 x l420 x L420mm

Usage : Exhibition Stele, Console

Bespoke finish upon request



*MOD001, module simple 1x1 haut, Studio Shot*  
Photo : Geste.s ©



*MOD001, module simple 1x1 haut, Studio Shot*  
Photo : Geste.s ©





*MOD001, module simple 1x1 haut*  
Photo : Geste.s ©







MOD001, module simple 1x1 haut  
Photo : Geste.s ©



MOD001, module simple 1x1 haut, Assembly Detail  
Photo : Geste.s ©



**MODULE TRIPLE HAUT - 1X3H**

Dimensions : H670 x l420 x L1020mm

Usage : Console, Exhibition Stele, Side Table

Bespoke finish upon request



MOD001, module simple 1x3 haut, Studio Shot  
Photo : Geste.s ©



MOD001, module simple 1x3 haut, Studio Shot  
Photo : Geste.s ©







**MOD001.IKI - MODULAR SYSTEM WITH UNLIMITED POSSIBILITIES**

Few exemples of modules, tu built and assemble

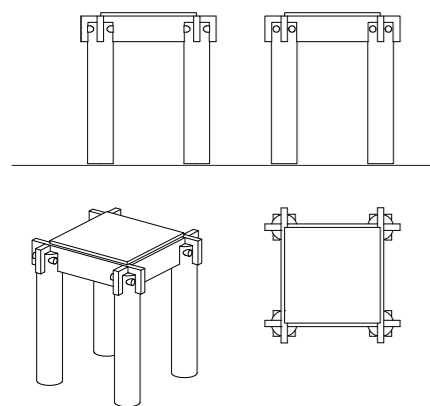

**MOD.1X1.B**  
4x pieds 440, 4x poutres simples, 8x tourillons, 1x plaque

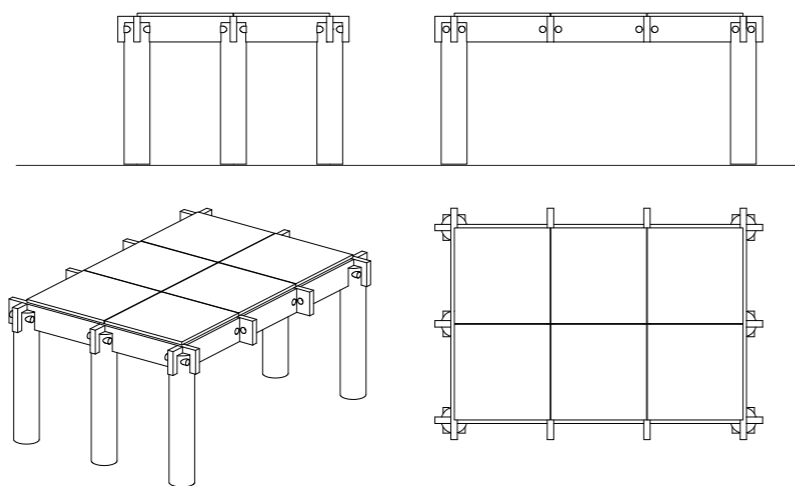

**MOD.2X3.B**  
6x pieds 40, 4x poutres doubles, 3x poutres triples, 12x tourillons, 6x plaques

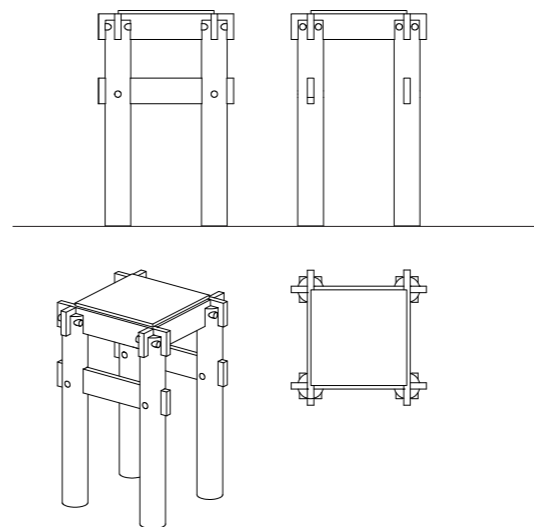

**MOD.1X1.H**  
4x pieds 640, 6x poutres simples, 12x tourillons, 1x plaque

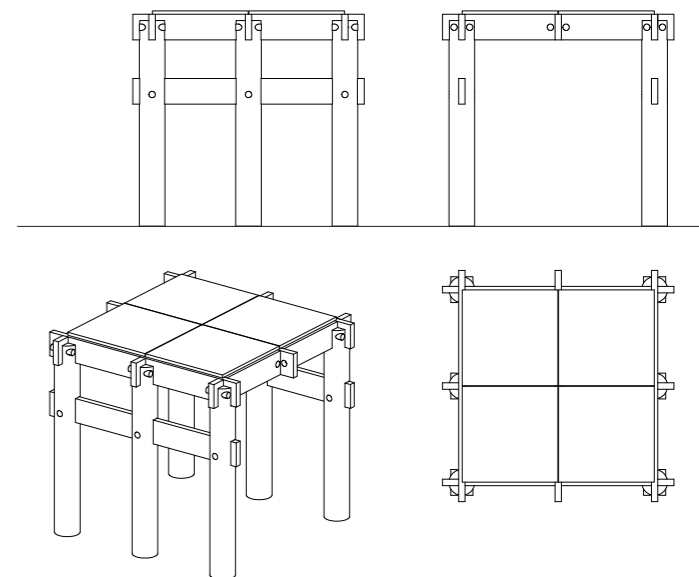

**MOD.2X2.H**  
6x pieds 640, 8x poutres doubles, 18x tourillons, 4x plaques

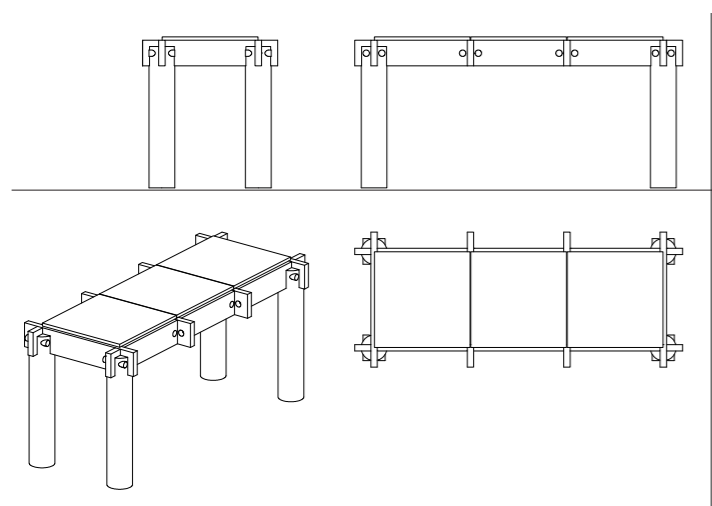

**MOD.1X3.B**  
4x pieds 40, 4x poutres simples, 2x poutres triples, 8x tourillons, 3x plaques

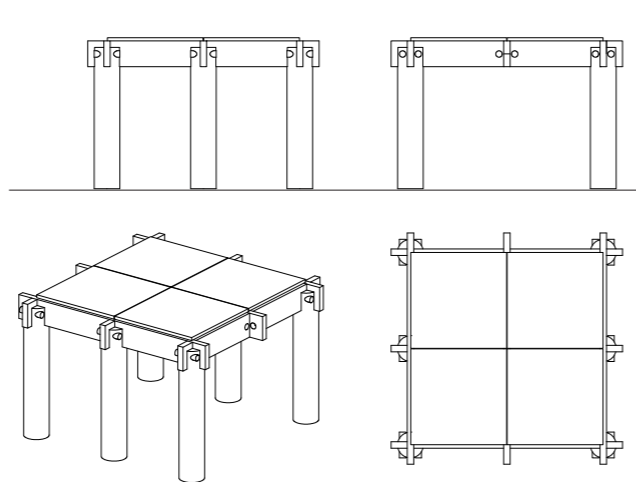

**MOD.2X2.B**  
6x pieds 440, 6x poutres doubles, 12x tourillons, 4x plaques

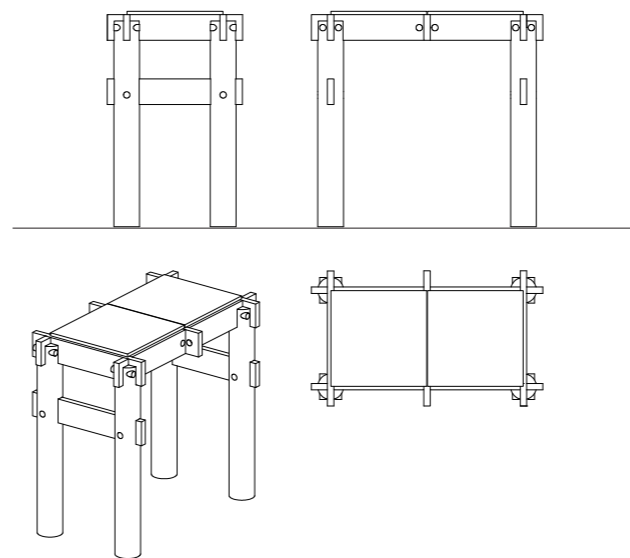

**MOD.1X2.H**  
4x pieds 640, 5x poutres simples, 2x poutres doubles, 12x tourillons, 2x plaques

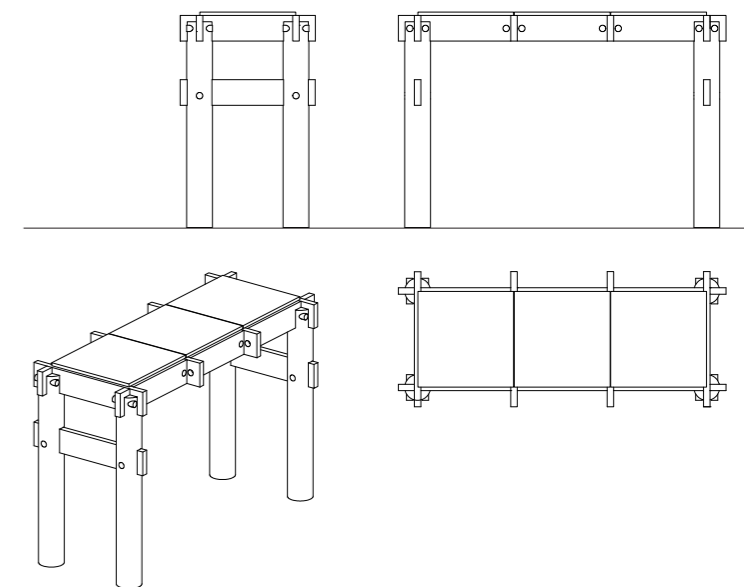

**MOD.1X3.H**  
4x pieds 640, 6x poutres simples, 2x poutres triples, 12x tourillons, 3x plaques



**THOMAS MORINEAU BARTHELEMY**

Architect HMONP

Designer

**FROM URBAN ARCHITECTURE TO OBJECT ARCHITECTURE**

A 2017 HMONP architect trained at ENSA Paris-Malaquais, Thomas Morineau Barthélémy founded the Geste-s design agency in 2022 after years of training between Japan, Switzerland and France, on large-scale projects, like pieces of the city. From urban project to piece of furniture, the jump in scale is striking and yet so obvious; it's a question of moving from the architecture of the city to the architecture of the object

Immediately after the Toulon Design Parade in 2022, where he was a finalist with his scenography project La Taule e l'Oustau, the dream kitchen of Frédéric Mistral, Thomas Morineau Barthelemy returned to his aspirations. As a child, he used to draw chairs and lamps in his sketchbook, which gradually led him towards architecture and urban planning, with a desire to understand the large scales and ways in which space and the city are made.

The Atelier de Création Geste.s enables her to bring together the manual skills of various craftsmen with her design drawings. The collaboration that results from this meeting is the very essence of Geste.s.

Acting at different scales, from the building to the object and vice versa, he wanted to make Geste.s an interdisciplinary platform driven by raw materials and the highlighting of artisanal gestures.

*"We see our projects, whether for furniture, scenography or architecture, as a succession of exchanges, discussions and gestures between use, design and production. I'm convinced that it's from this exchange that creativity and the rightness of a project are born,"* says Thomas Morineau Barthelemy.

MOD001.Iki, Portrait

Photo : Geste.s ©





**THOMAS MORINEAU BARTHELEMY**

Architecte HMONP  
Scénographe  
Designer

**EXPOSITIONS, PRIX ET PUBLICATIONS**

**2024** – “MOD001.Iki”, First show of the Modular System “MOD001.Iki”, Paris Design Week Factory, Espace Commines, Paris, France

**2024** – “La Taulo e l'Oustau”, Collectible Design Collection, First Show at Collectible Brussels, The Fair for 21st Century Design, Architect > Designer, Espace Vanderborght, Brussels, Belgium

**2023** – Exclusif exhibition of “LUM002 Pampilles” from “La Taulo e l'Oustau”, For Goodmoods Rue de Seine, Paris, France

**2022** – “La Taulo e l'Oustau, la Cuisine Rêvée de Frédéric Mistral” - Personal Exhibition at Design Parade Toulon 6ème Festival international d'architecture d'intérieure pour la Villa Noailles - Toulon, France

**2016** – Publishing of “Vers la disparition progressive de Rikuzentakata” - ENSA Paris-Malaquais, Paris, France

**2016** - Special Price from Directrice de l'ENSAPM for his Diploma “Vers la disparition progressive de Rikuzentakata, projet cyclique de renaturalisation de l'environnement urbain”, Paris, France

**2015** - First Price of the competition Tokyo 15 - Meiji University Tokyo, Japon

*MOD001.Iki, module 1x1 Haut, et module 1x3 Bas*  
Photo : Geste.s ©





T

M

B

**THOMAS MORINEAU BARTHELEMY**

---

**WWW.GESTE-S.COM**

MOD001.IKI  
+33(0)6 88 67 65 25  
tmb@geste-s.com

**GESTE.S**  
a.s.d