

# Outside In

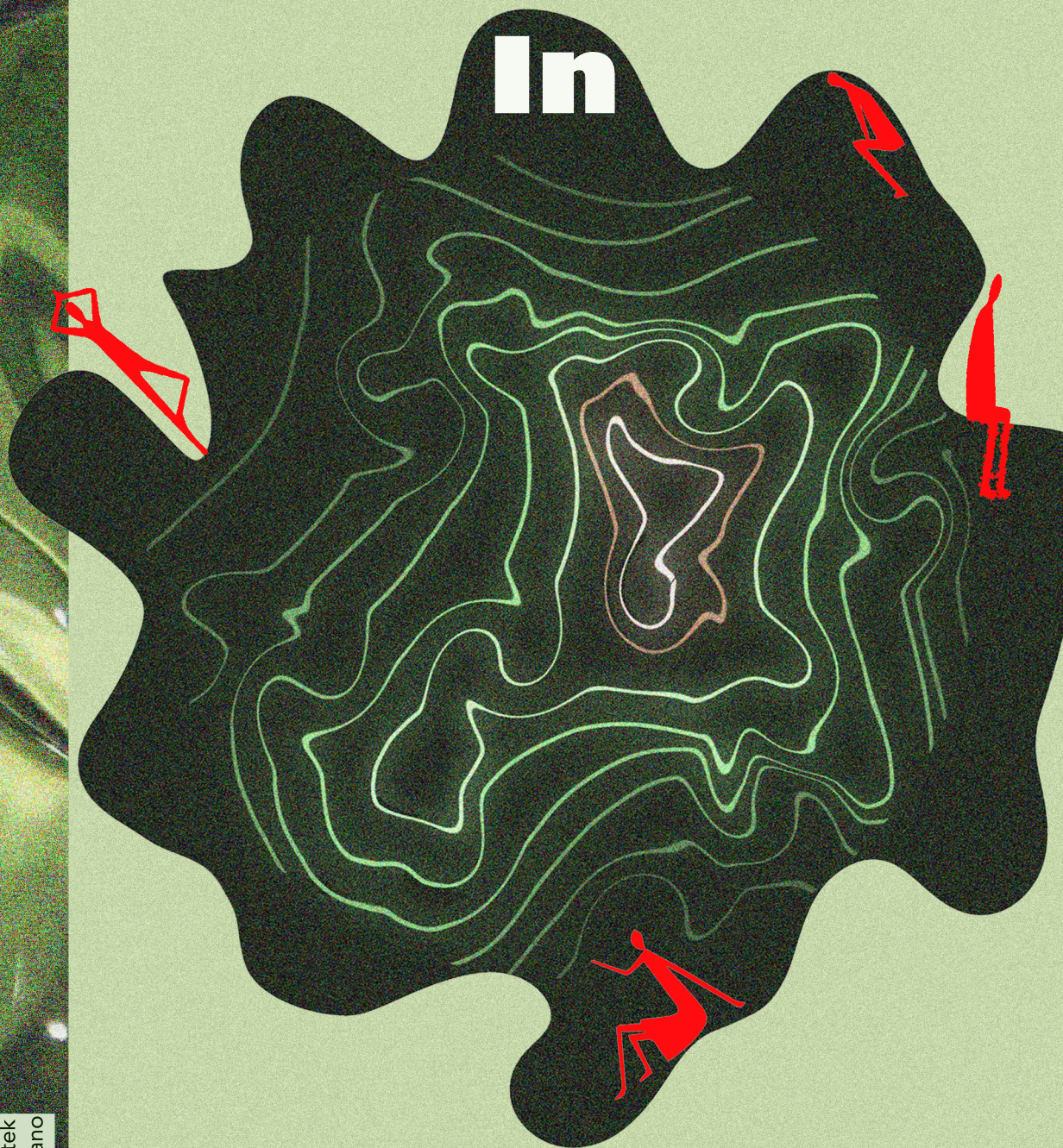

thuc tran  
mikayla zientek  
elena mexicano

most people never ~~penetrated~~ my own desire for simplicity, which is absolutely monumental in my work. you get more use from every cubic inch of space I liked not being observed.

Easy to move and ship, LIVING STRUCTURES are ... simple and inexpensive to produce...

Our aim here, partly, was to create a totally new, totally strange, even seemingly hostile environment

**Fabric**  
THE DANGER IS THAT INDIVIDUAL MAN MAY SOON FIND HIMSELF LOST IN IT

The configuration was so simple and the principles so susceptible to

variation that no great / barriers / existed to the fabrication of the units

a student is placed in an (ENVIRONMENT) by the user As the imagination of many men creates a fantastic new world

<<< completely outside of his normal >>> Living structures

**COLLABORATE** experience range and is exposed to rapidly presented INFORMATION in an intense and exciting atmosphere

It is by comparing that we LEARN. Creative Process (don't want to do things that are hard..... but I don't want to do things that are easy..... I want to do things that are just interesting.....)

I think in very simple terms; to THINK in a utopian mode would be an

enormous theoretical Becoming a child was a wonderful part of it. IT'S JUST VERY DIFFICULT TO PUT PEOPLE INSIDE A (FRAME)

Jump we understand 'togetherness' as a gathering of individuals around a collaborative situation

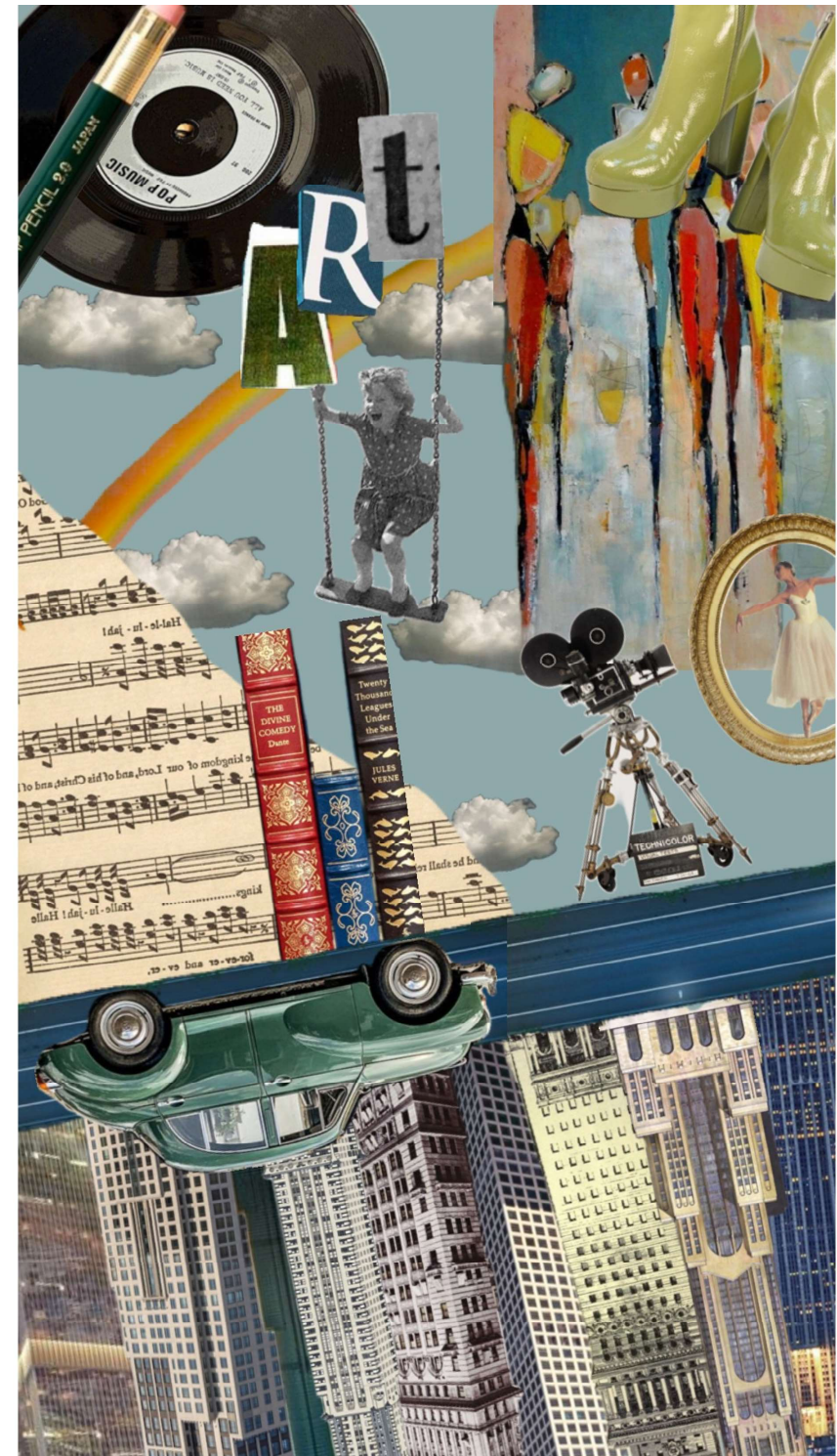

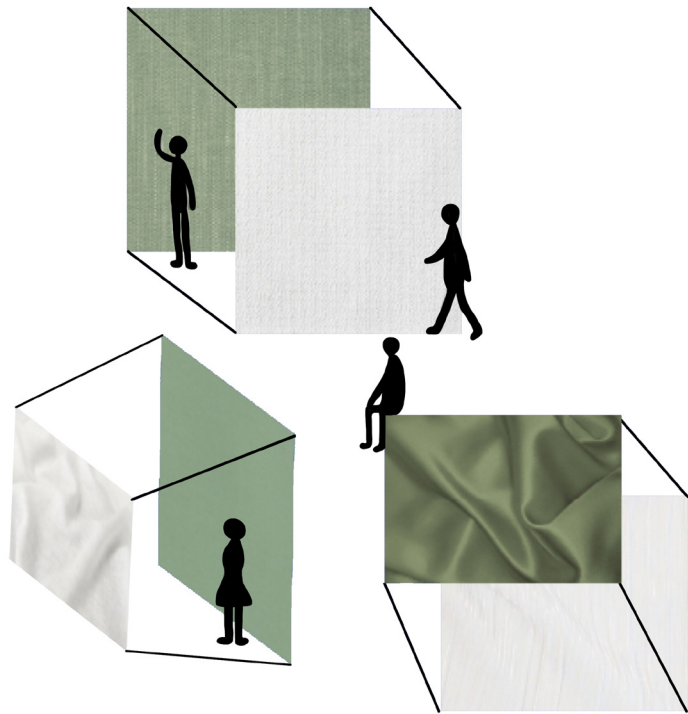

From the start, Outside In wanted to approach ergonomics, transformability, and joy through furniture that defied standard seating and lounging. Our project has been inspired by various designers, particularly Roberto Matta and Paolo Deganello-- who strategically utilized curves to revitalize comfort and the art of relaxation. Through many shape designs and lots of structural testing, we eventually found ourselves with a duo “snake” set that can be appreciated as both seating and sculptural pieces. Outside In’s structural components are left uncovered, and both pieces come with a detachable fabric “cushion” for extra comfort. Both “snakes” transform for every user when sat on-- bending based on weight so that there is contortion to the body. When in need of space, the pieces can be stacked and moved around to the site’s needs. Move them around to create your own landscapes, lay on them to become a part of the landscape, or admire the hilly curves from afar-- whichever you do, we’ve already brought the outside in!



Ergonomics is a science requiring an understanding of various aspects of people, such as differing heights, disabilities, ages, and weights. Designers aim to create more efficient environments, whether in terms of productivity, comfort, or accommodation. Through ergonomics, we gain a thorough understanding of what the human body considers comfortable. Ergonomics holds significant importance in the lives of interior architecture students like ourselves, who spend extensive periods seated. Our objective is to feel comfortable during our work, which enables us to focus better without being distracted by discomfort, particularly back pain. Giving priority to comfort is essential to ensure that designs not only please the eye but also

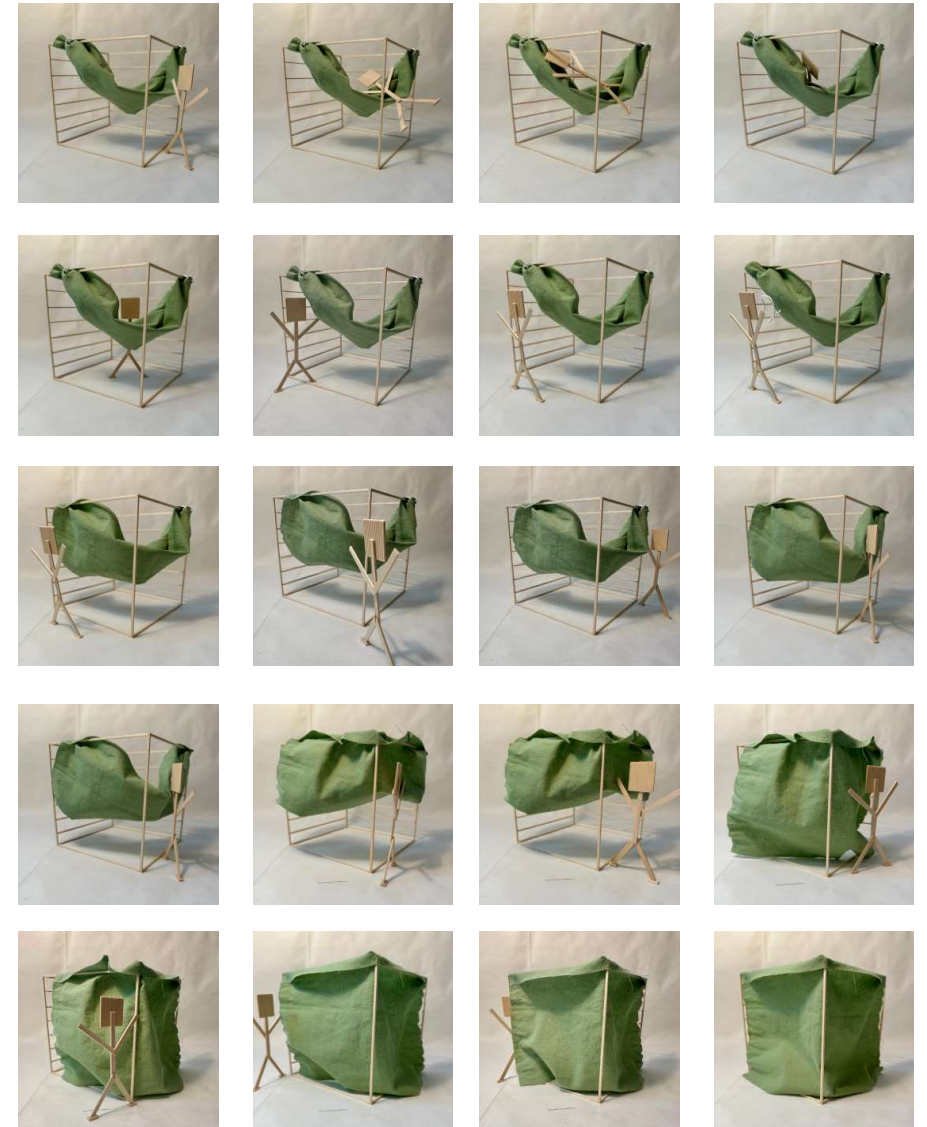
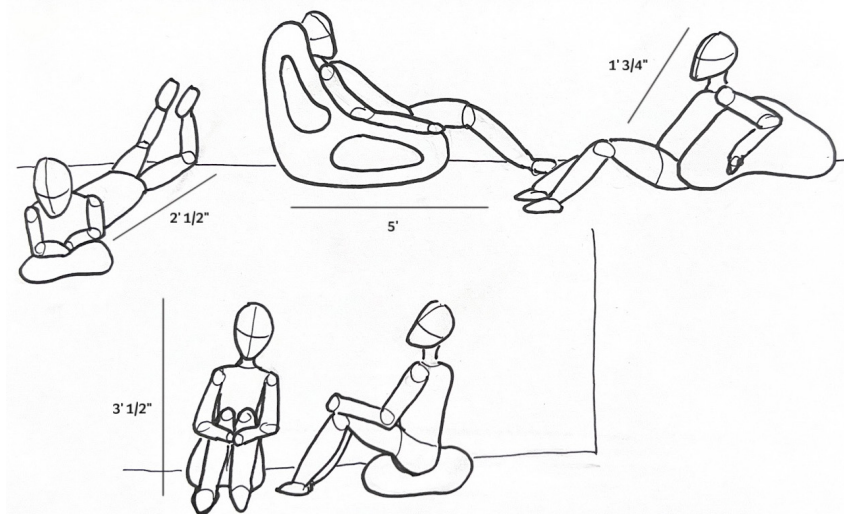
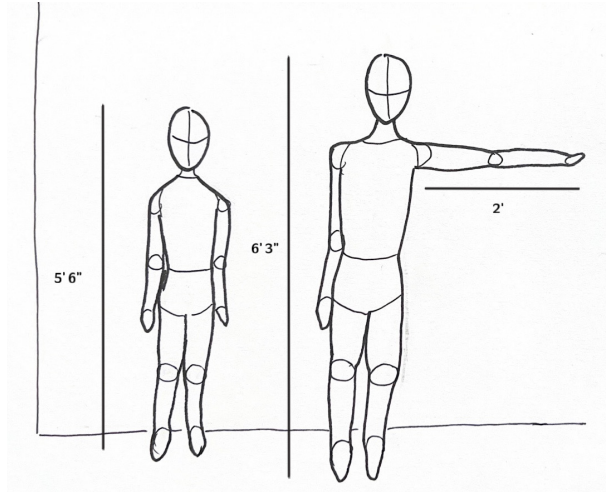

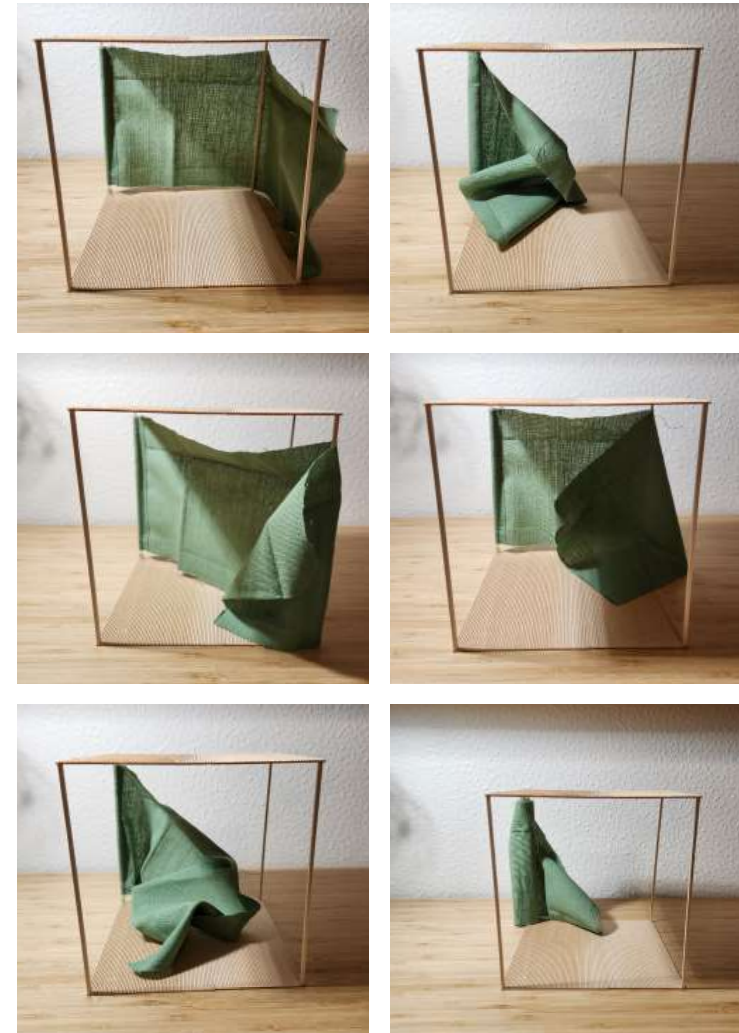
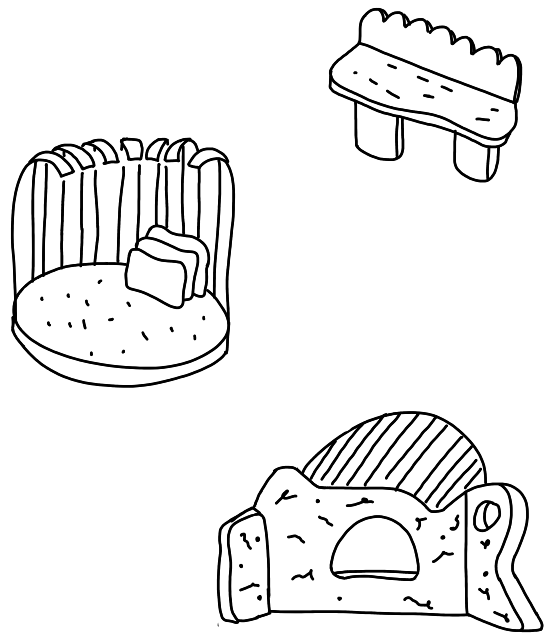

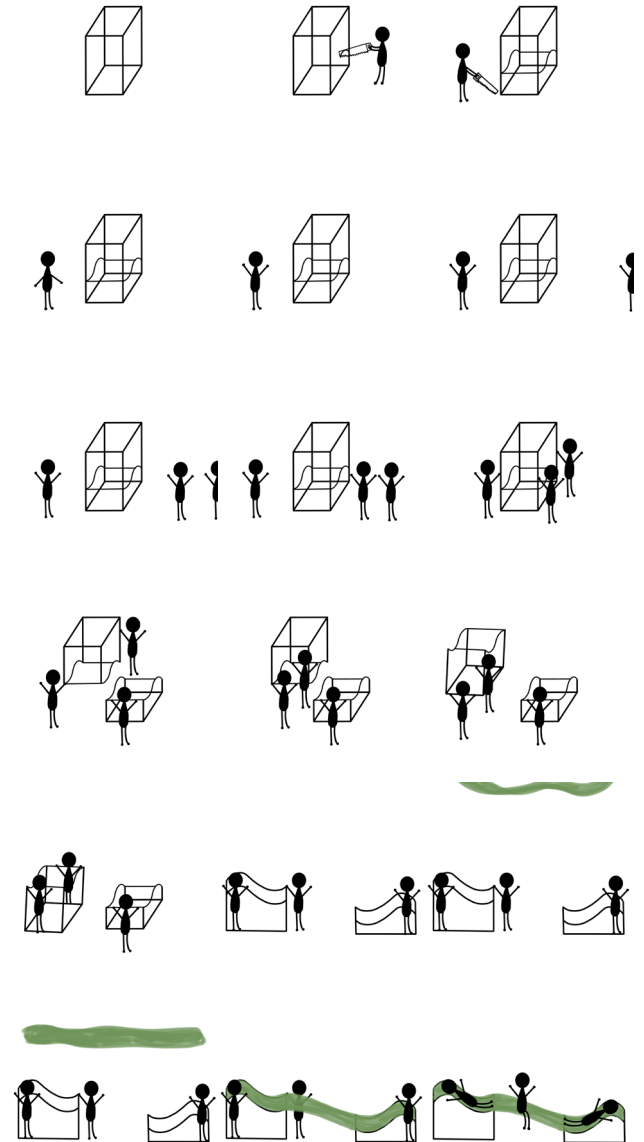
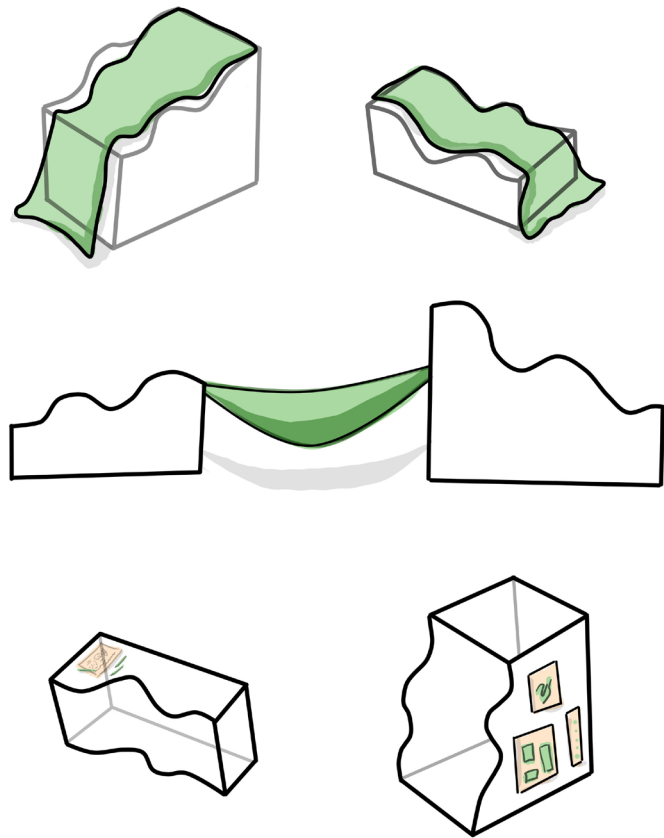

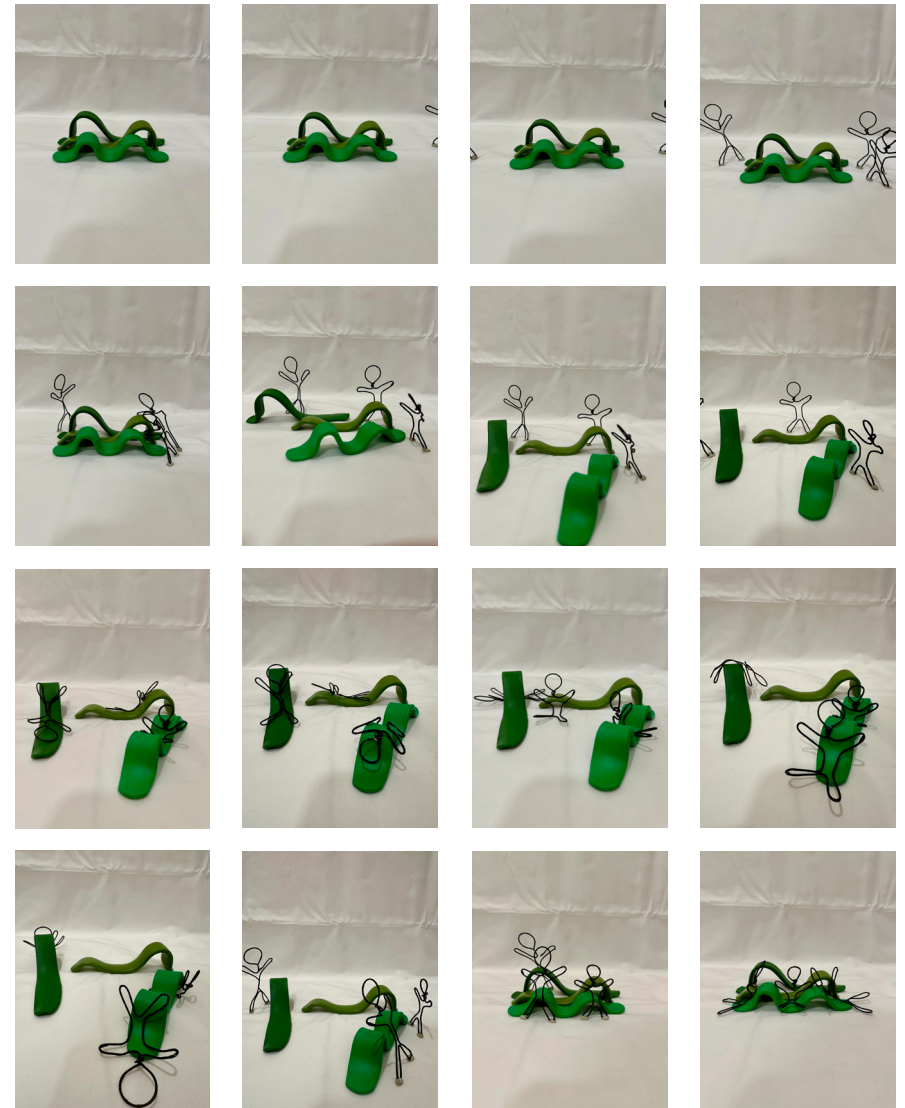
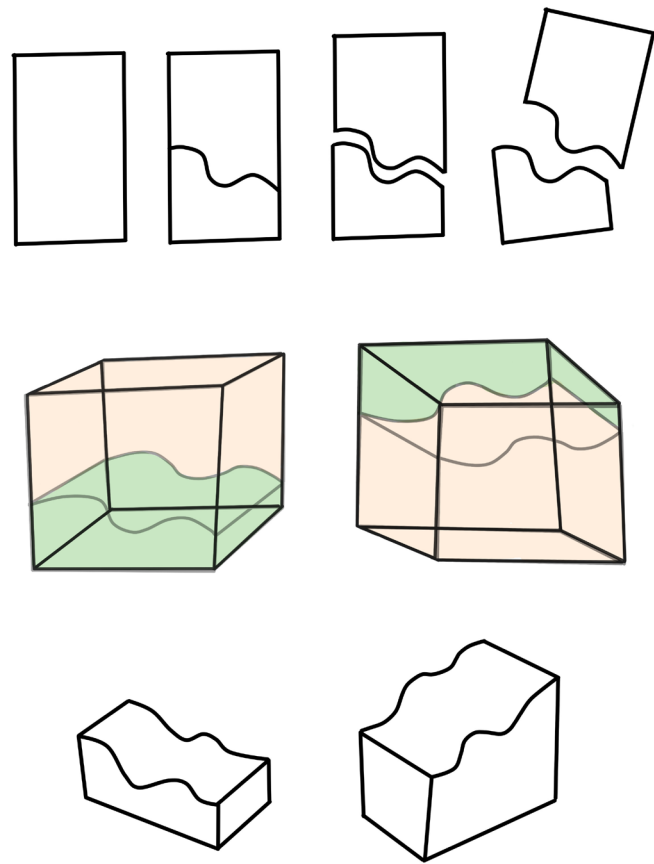



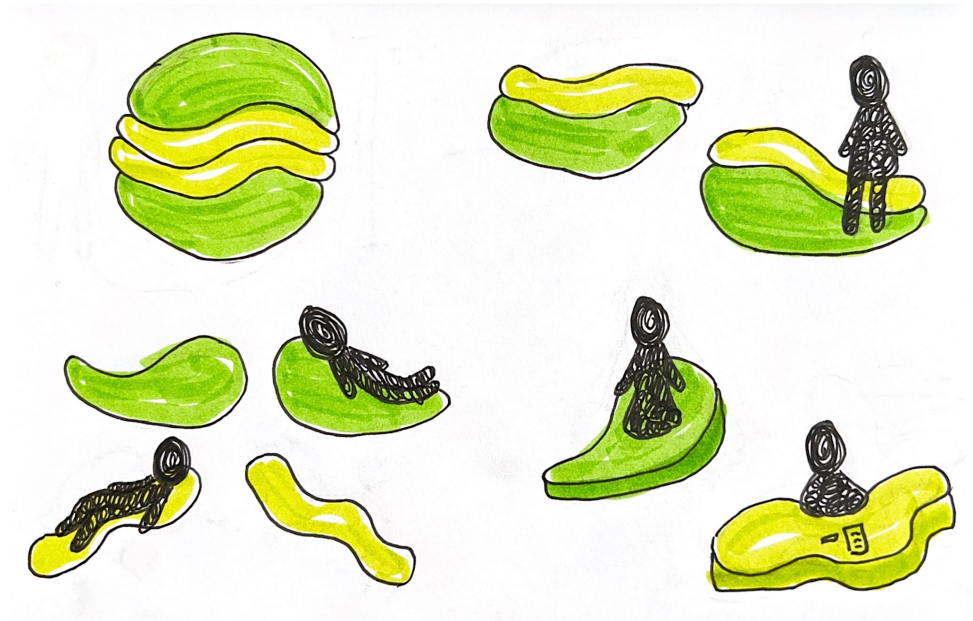

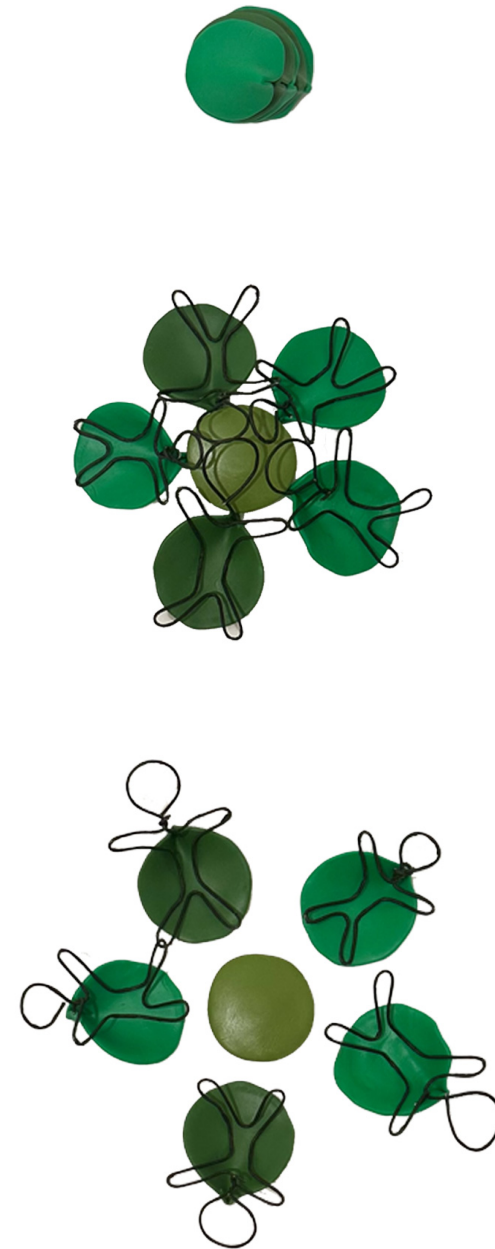
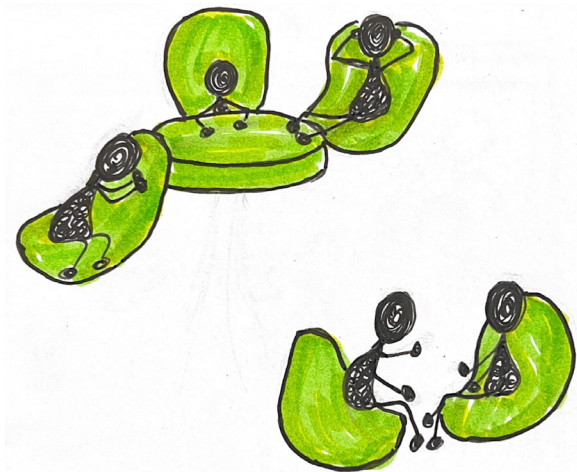

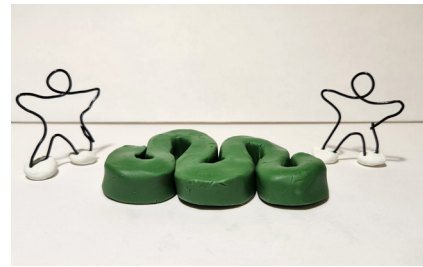
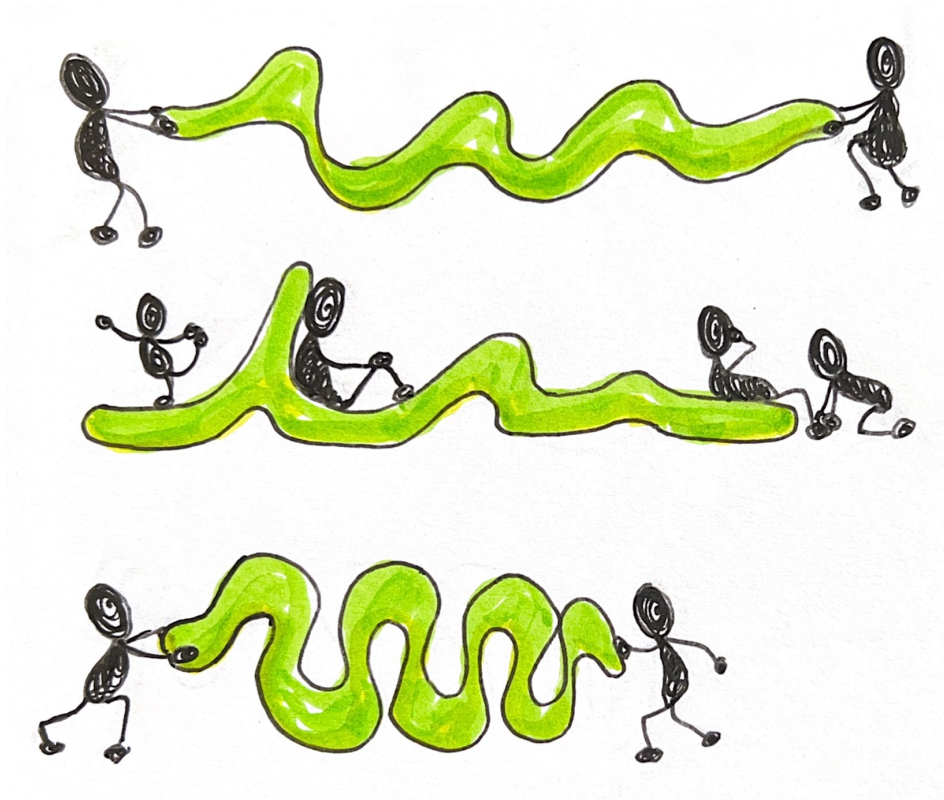

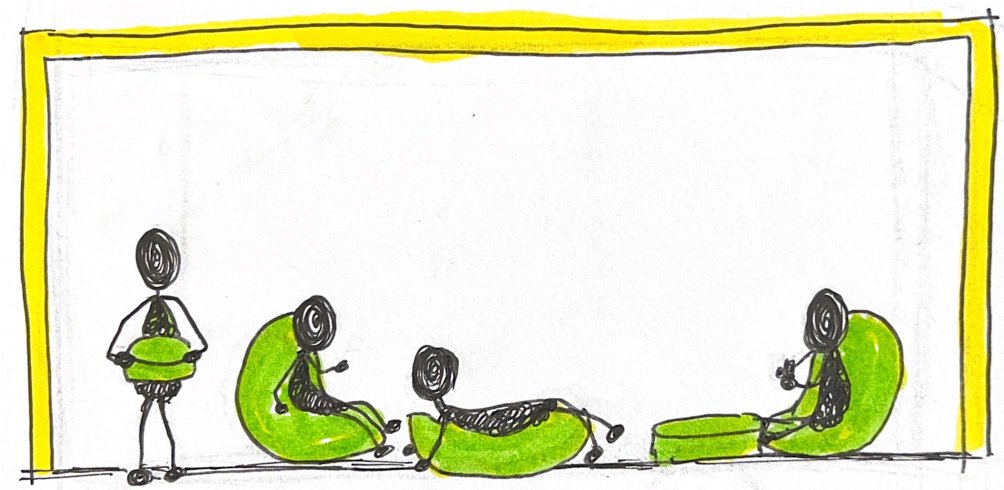
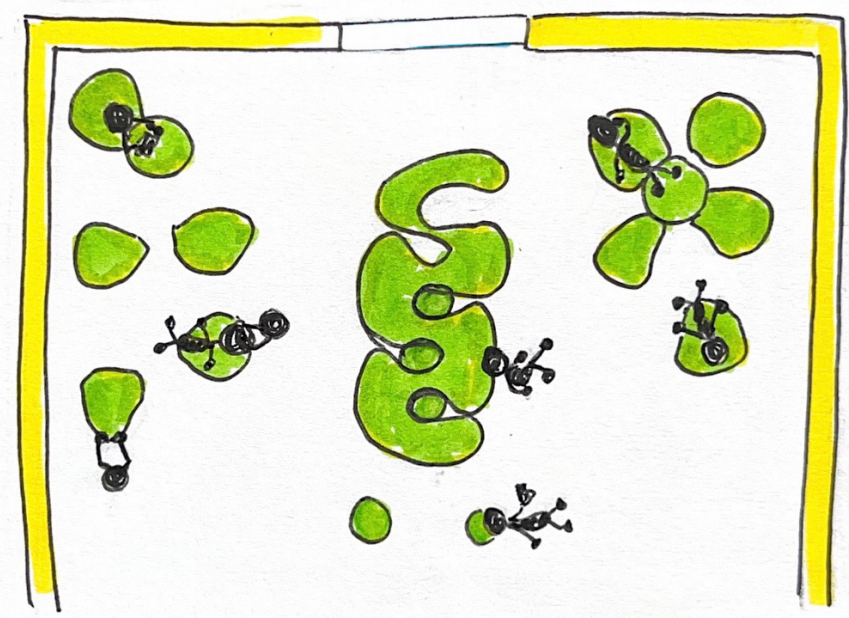

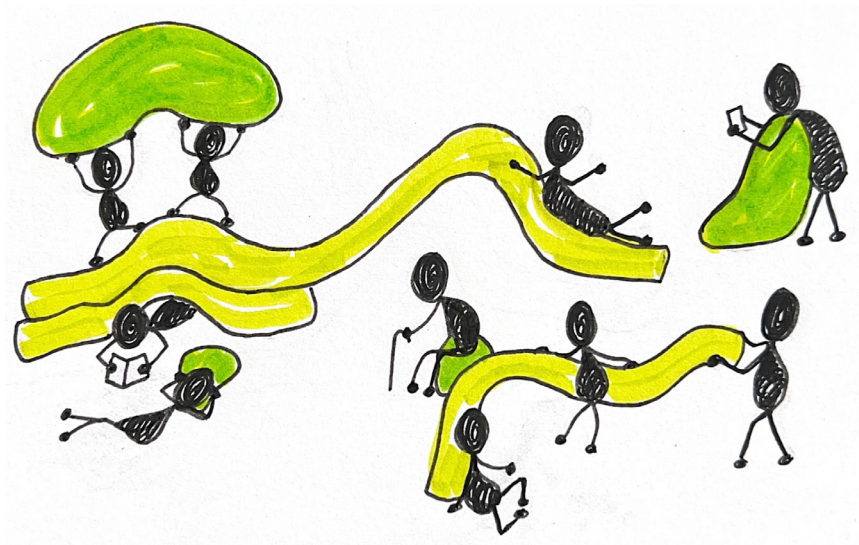

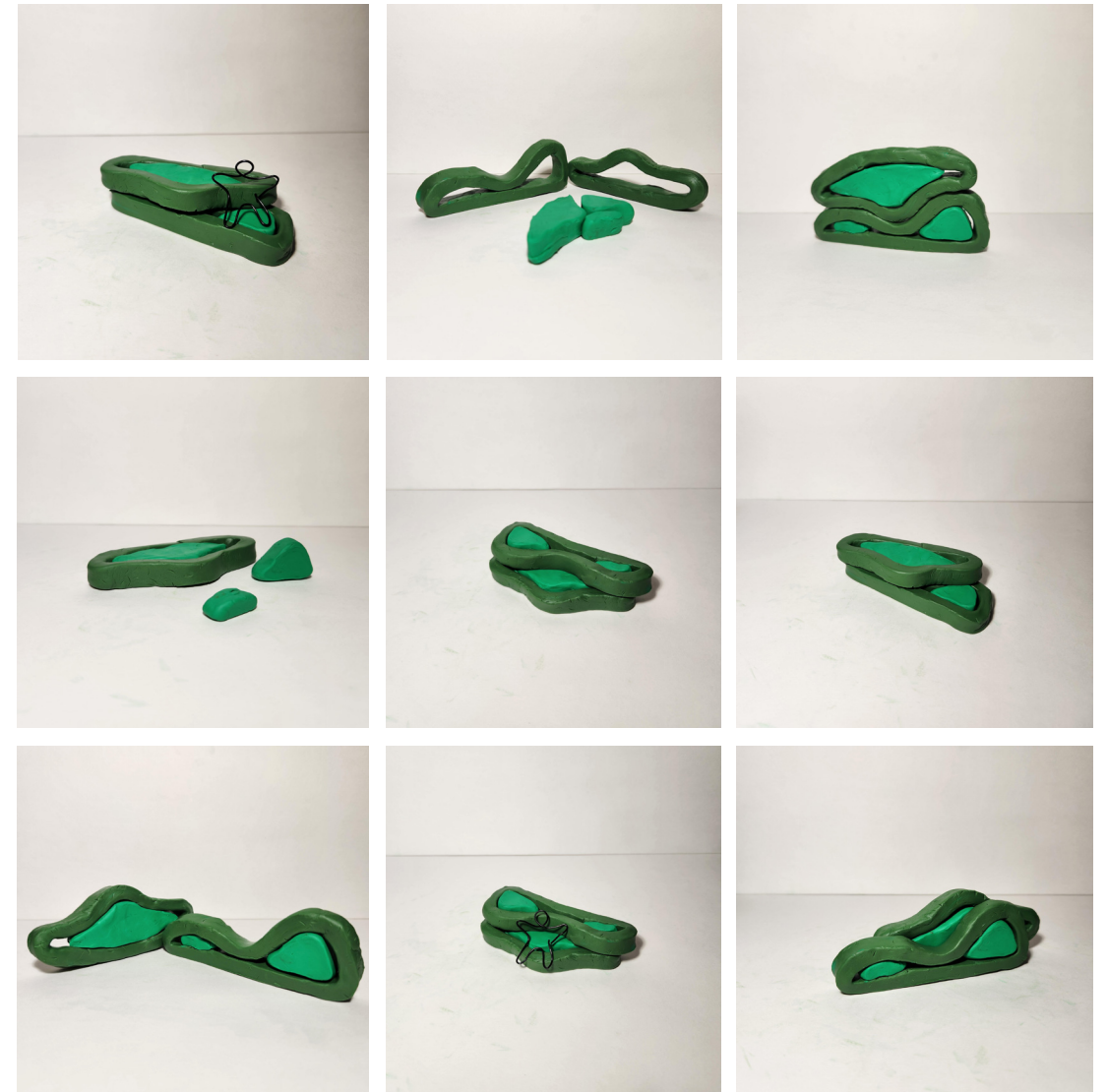
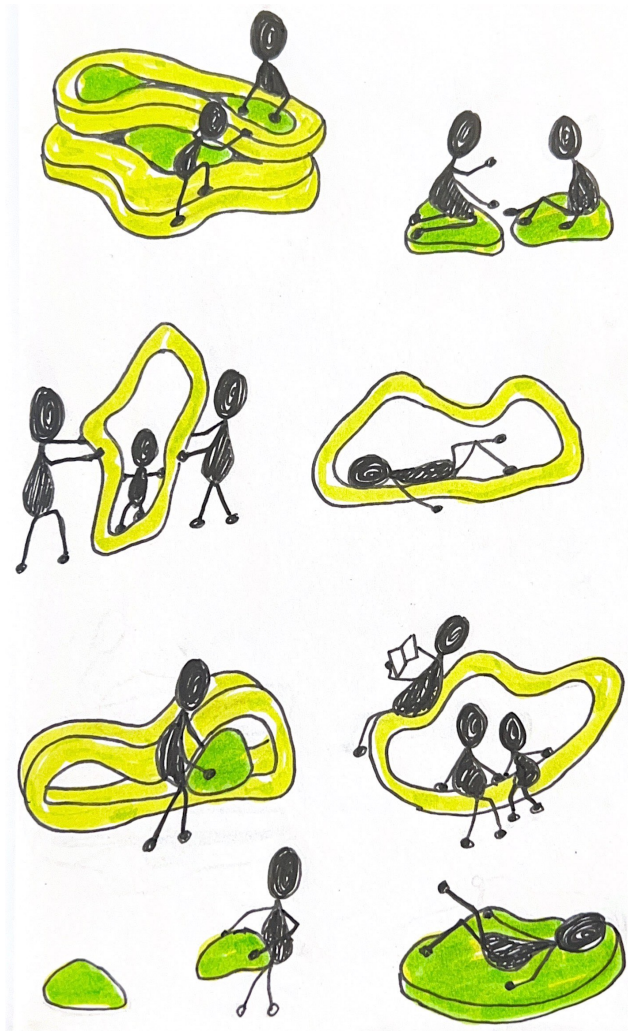



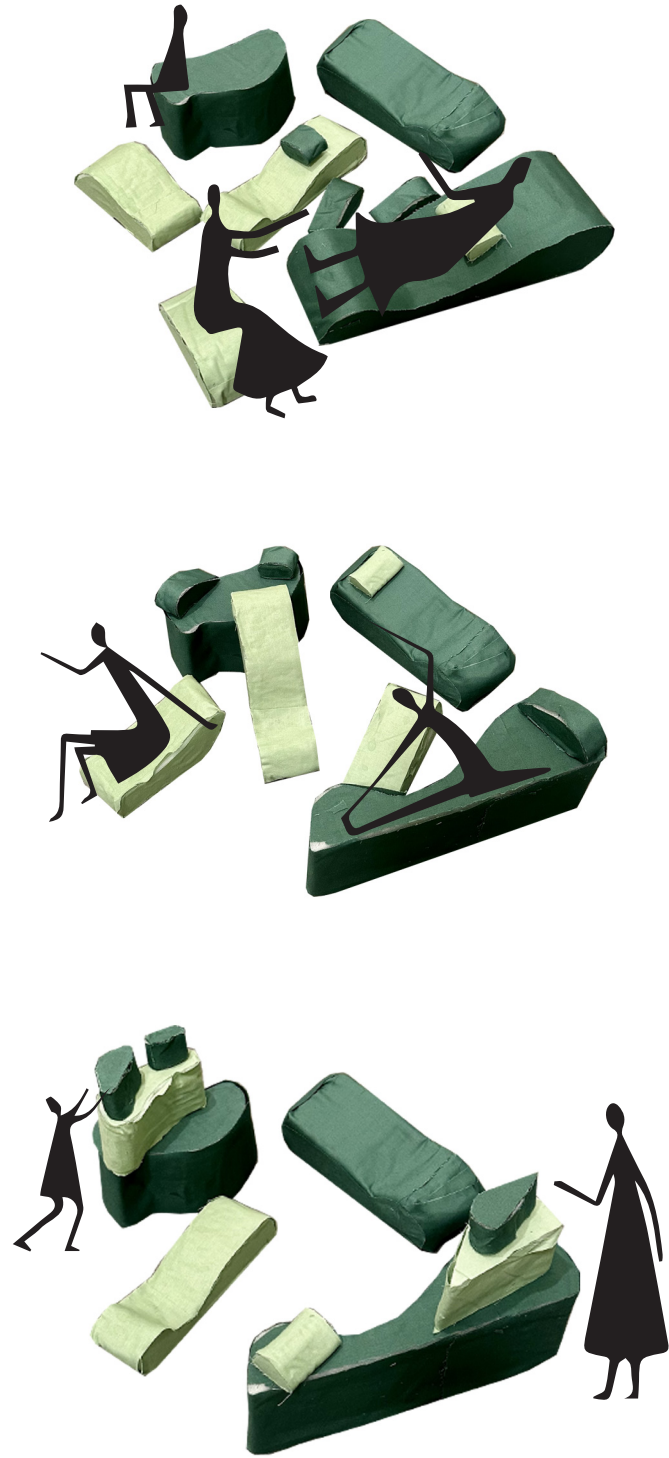

Model

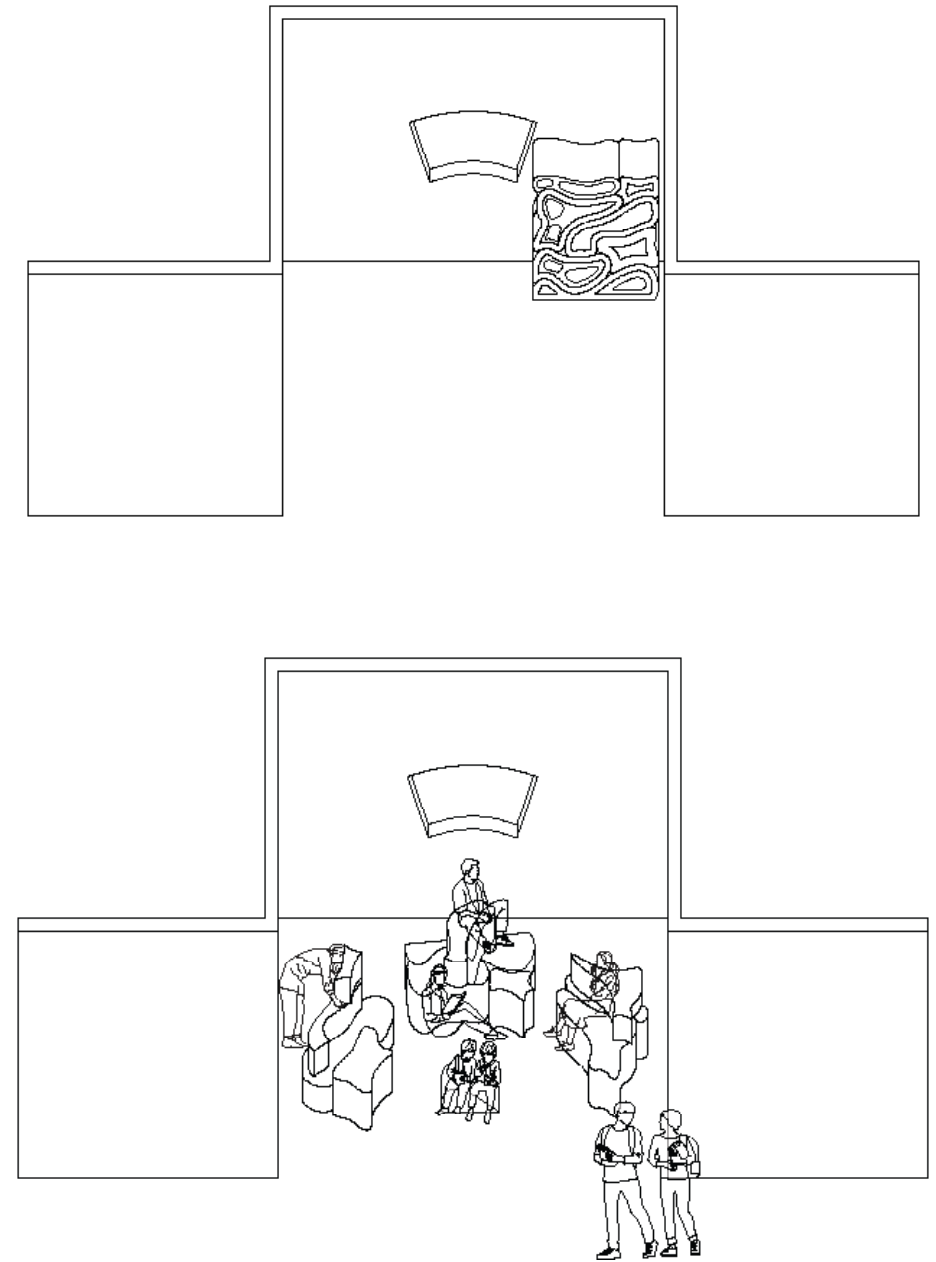

Axonometric



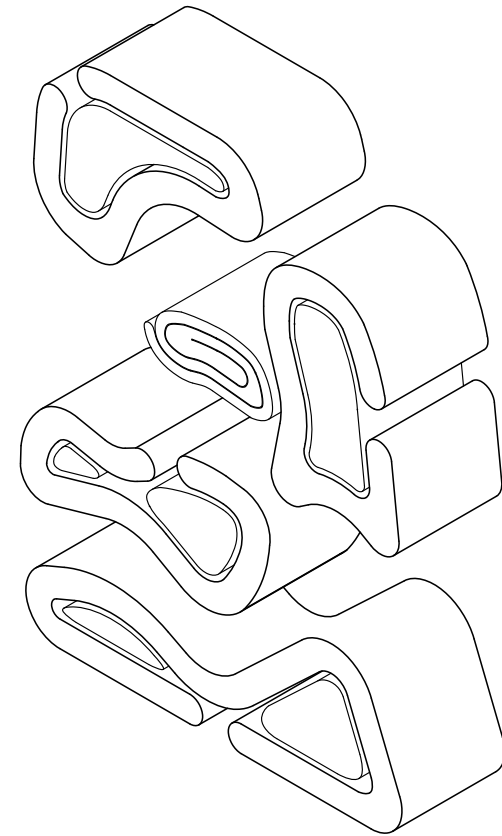
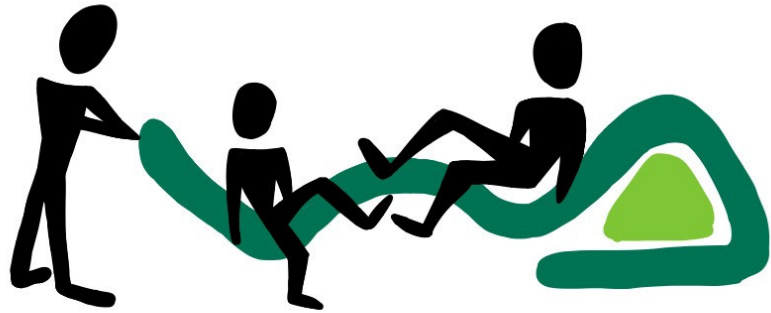

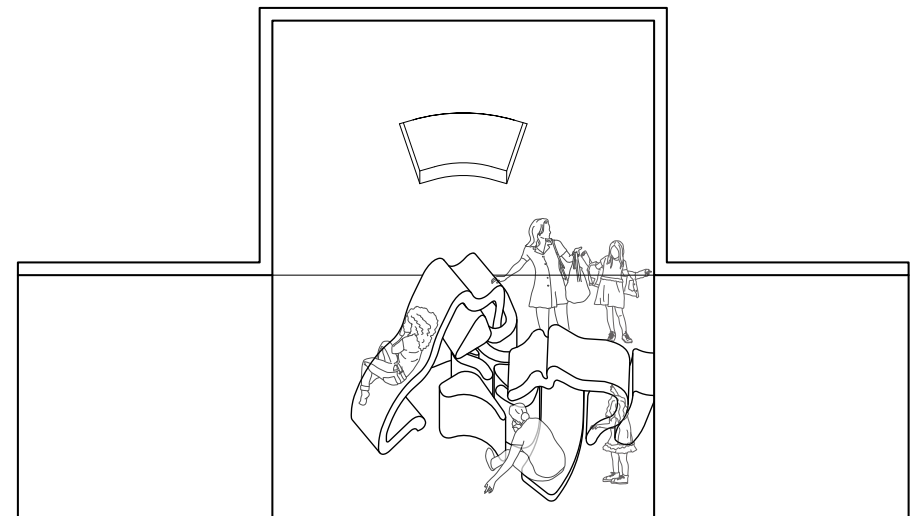
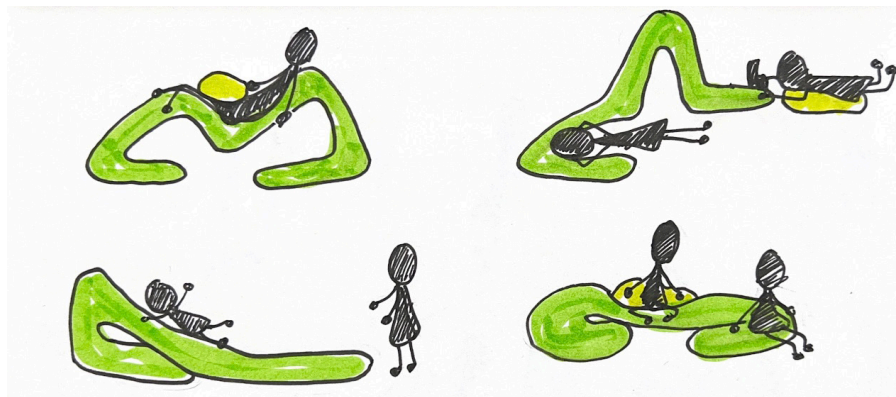
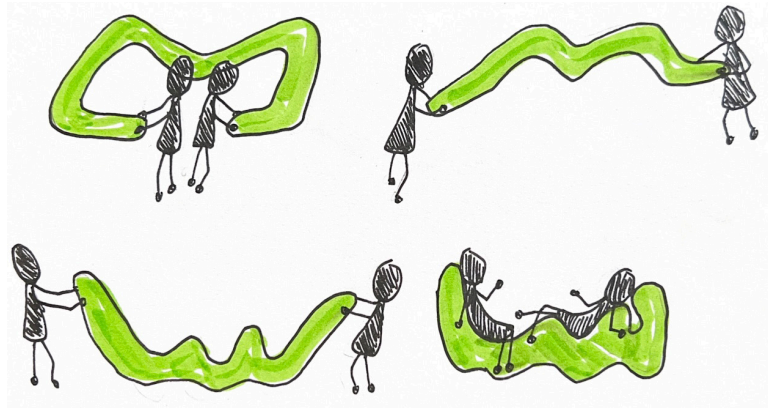

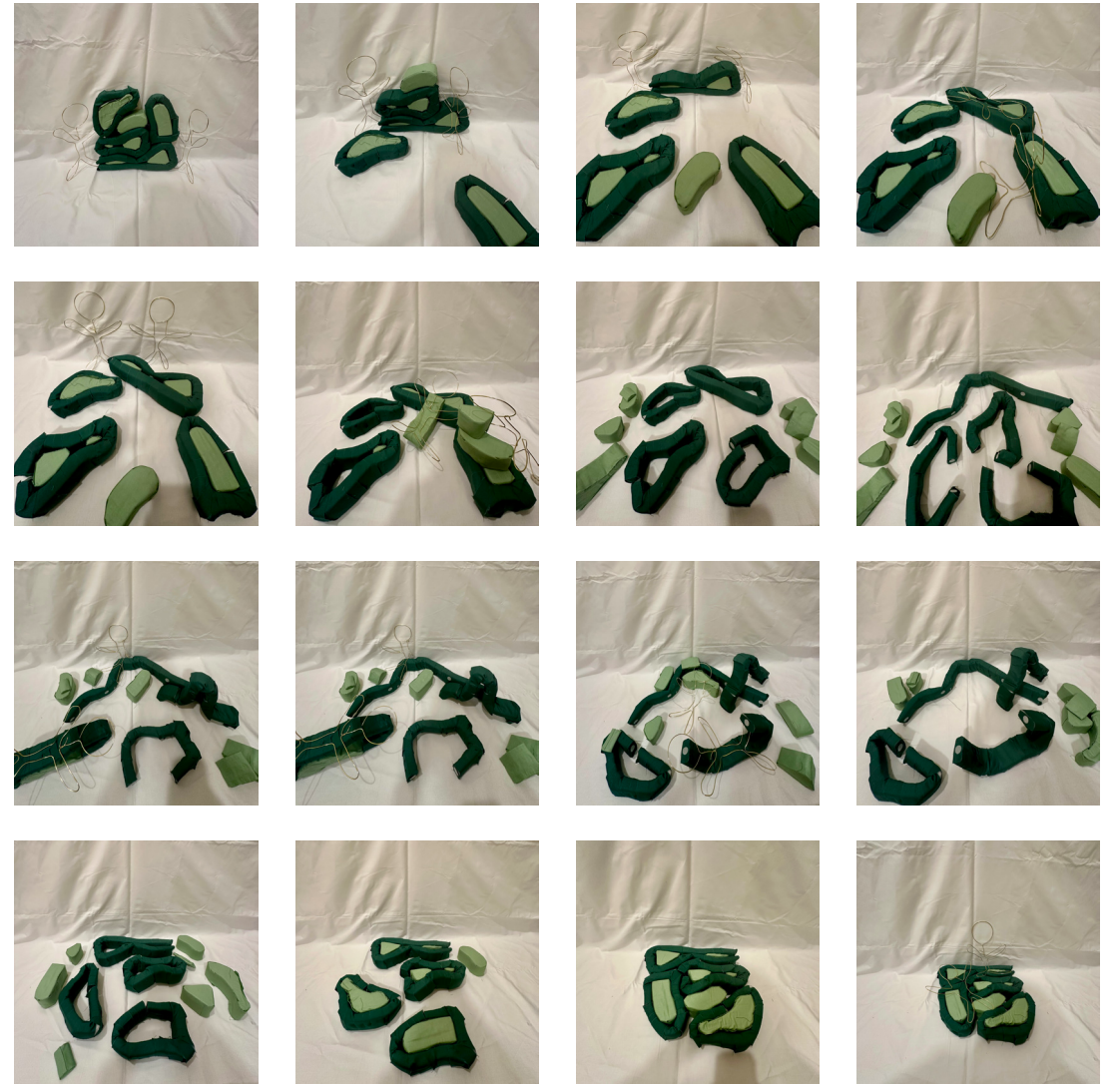

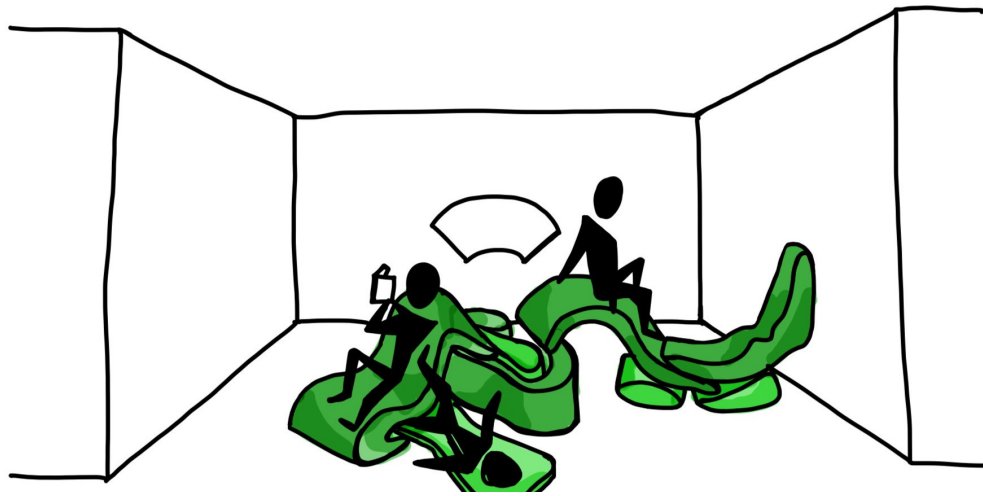

## Project 2



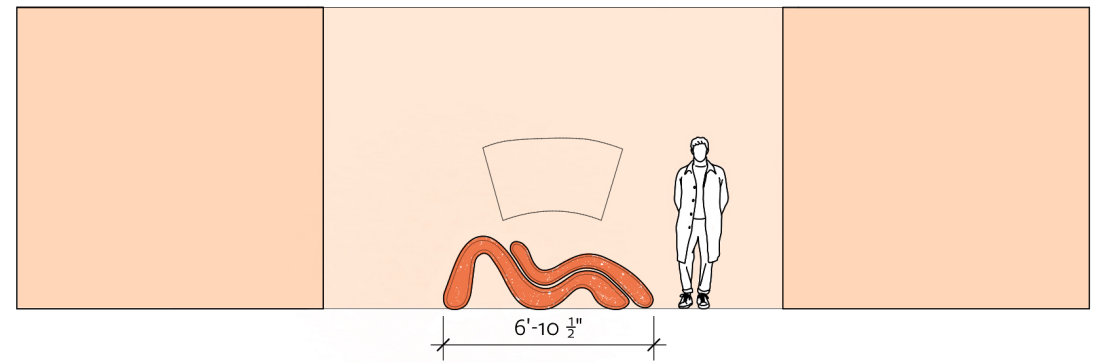

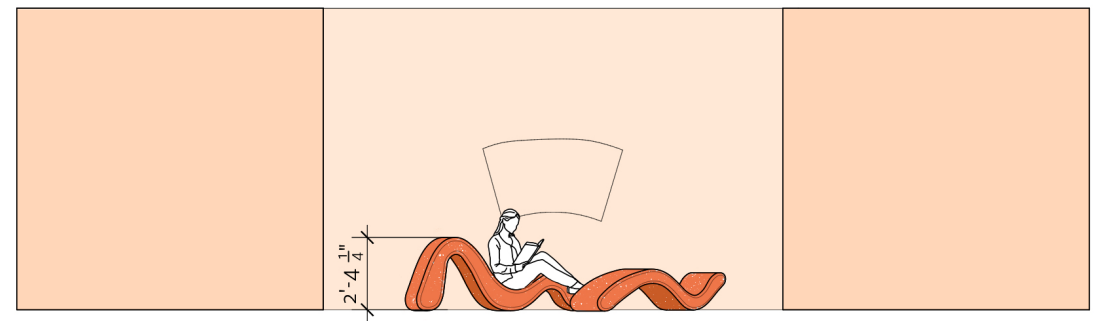
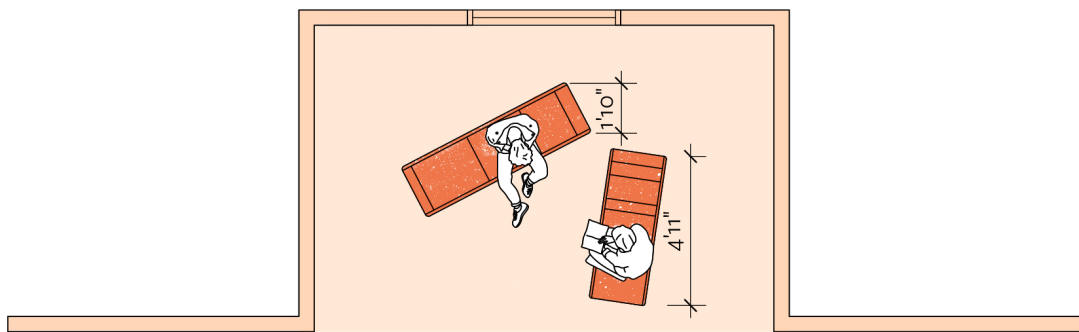

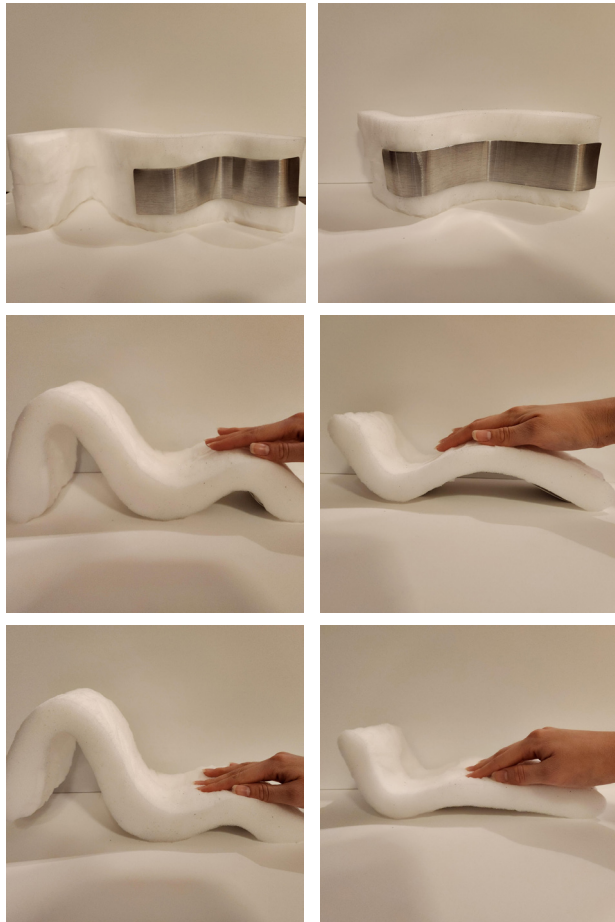

Structure Model



Model



# Project Integration

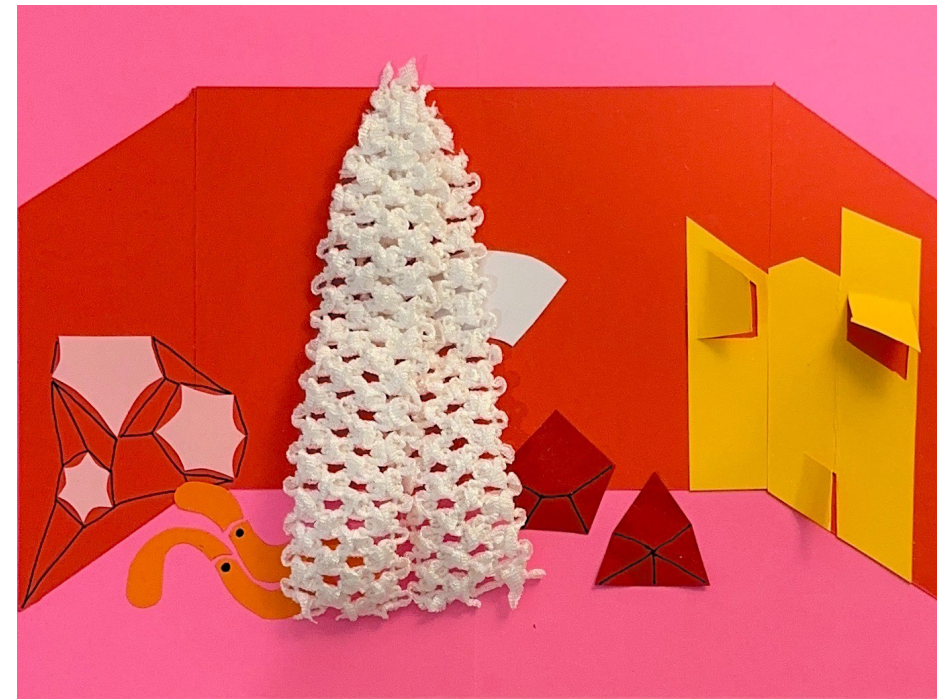

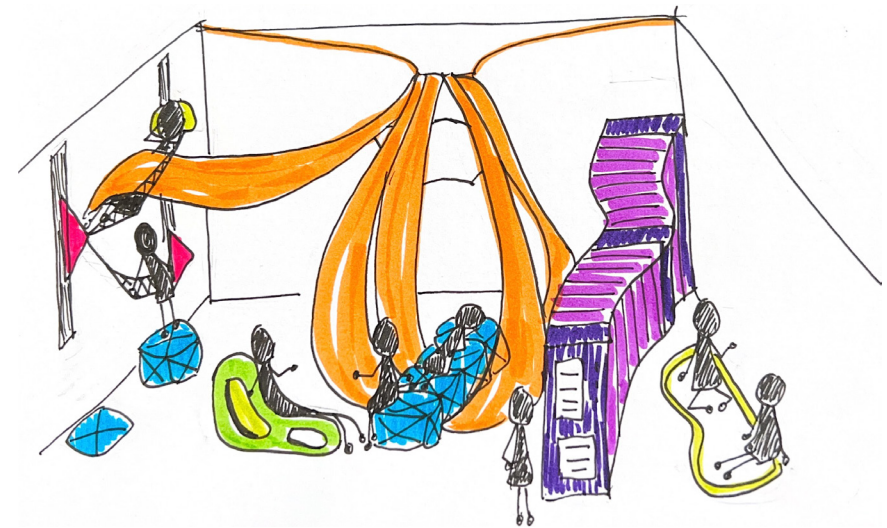
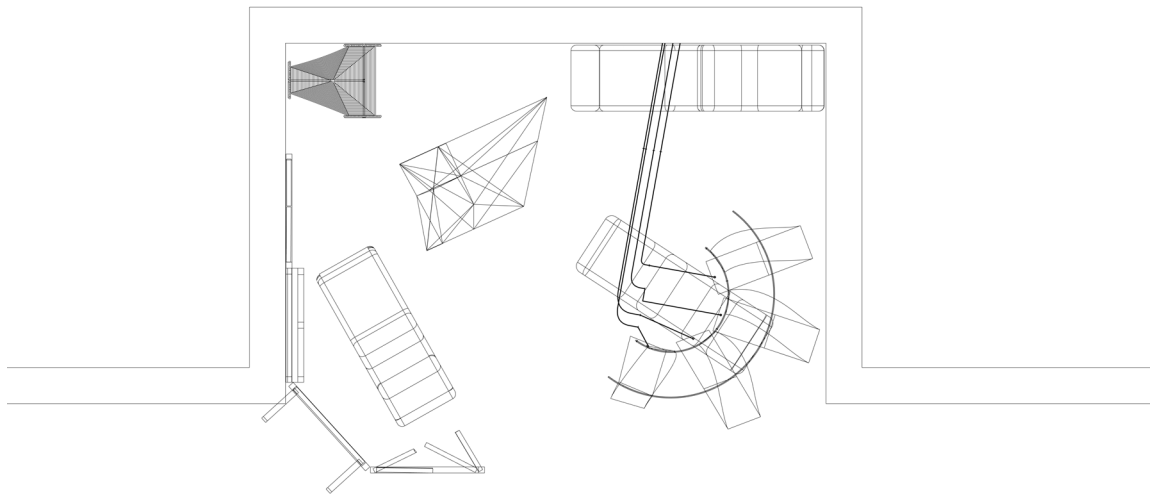

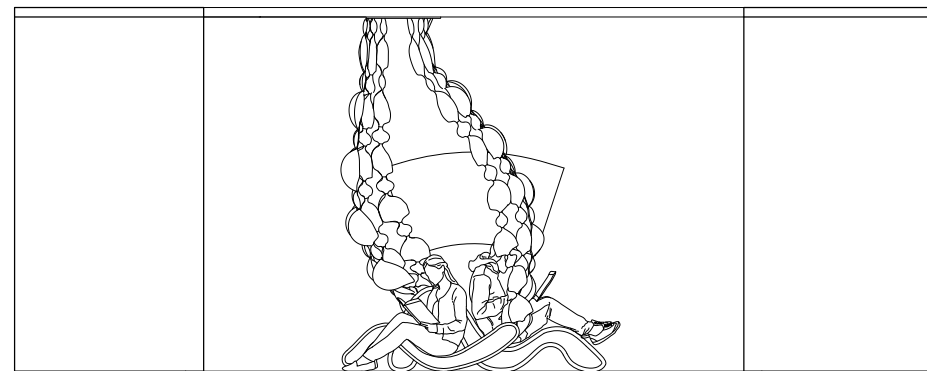
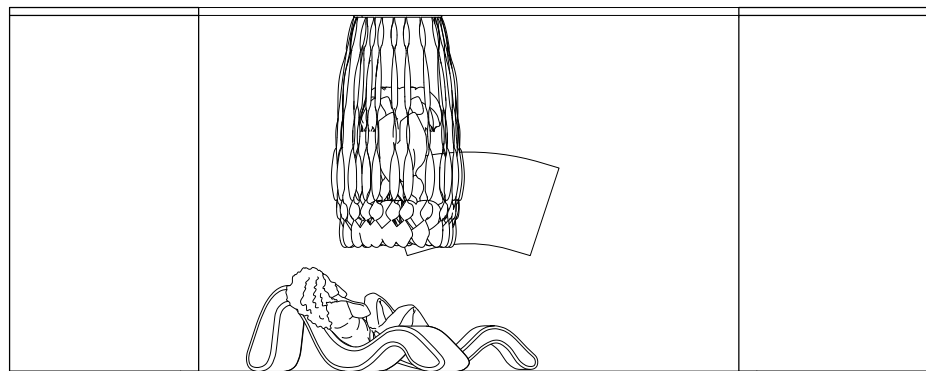

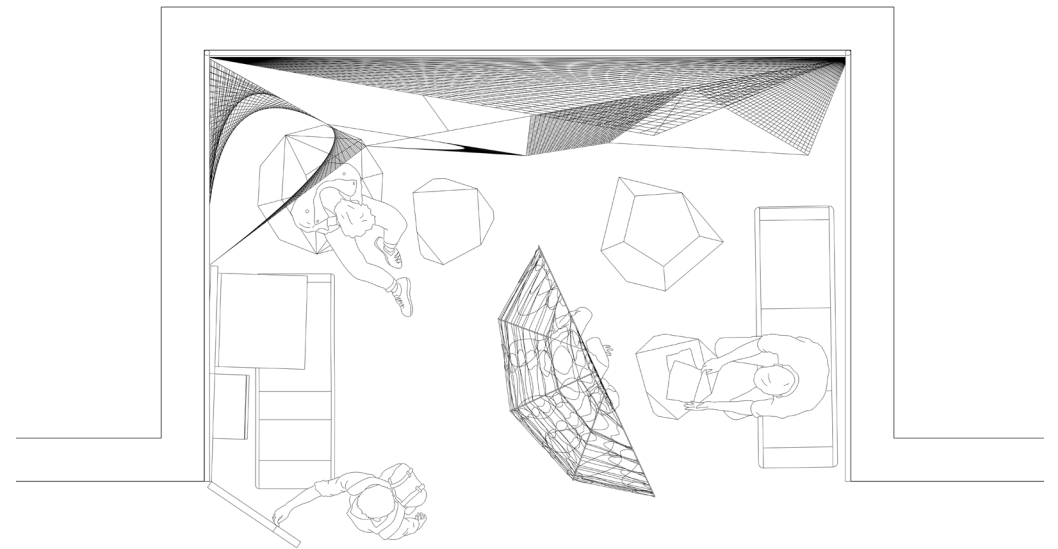
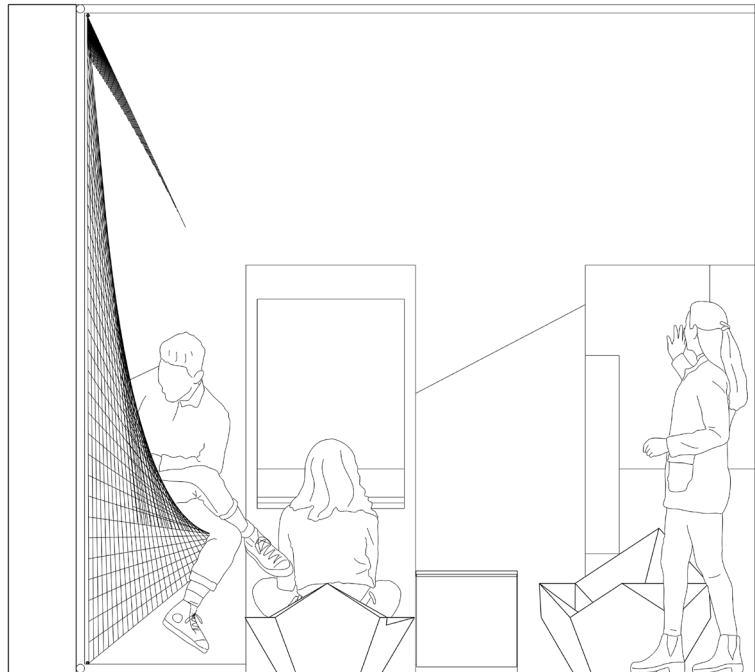

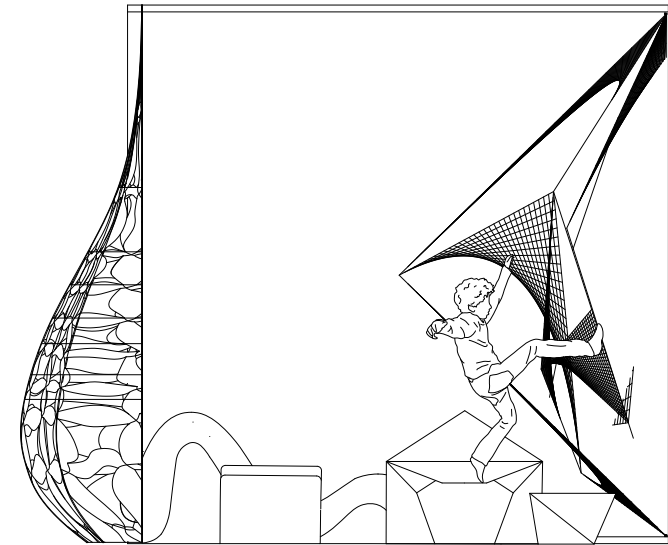
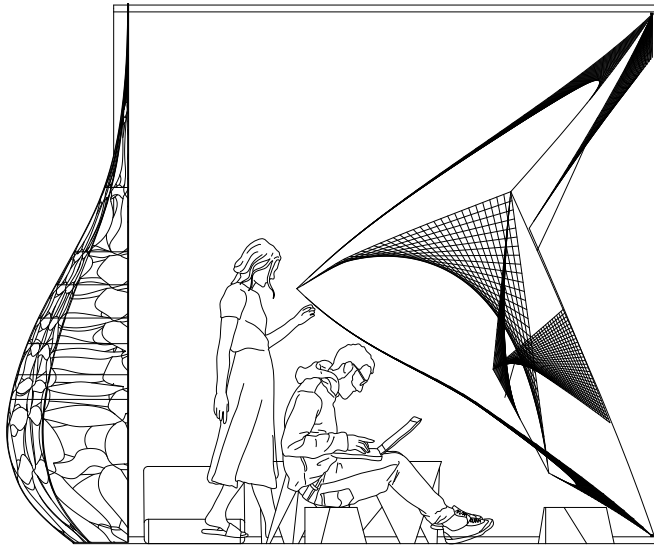
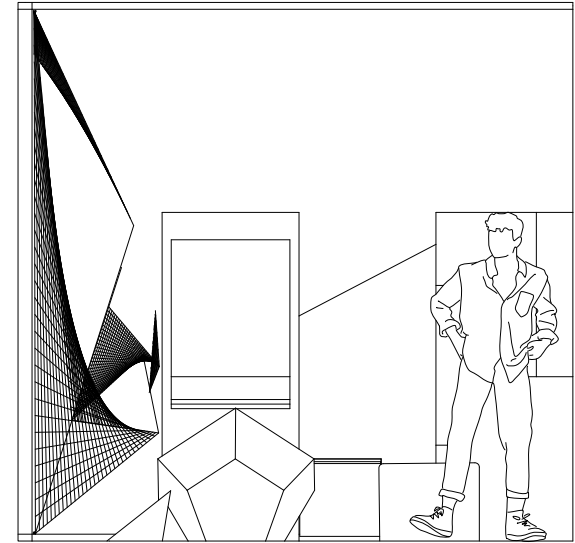
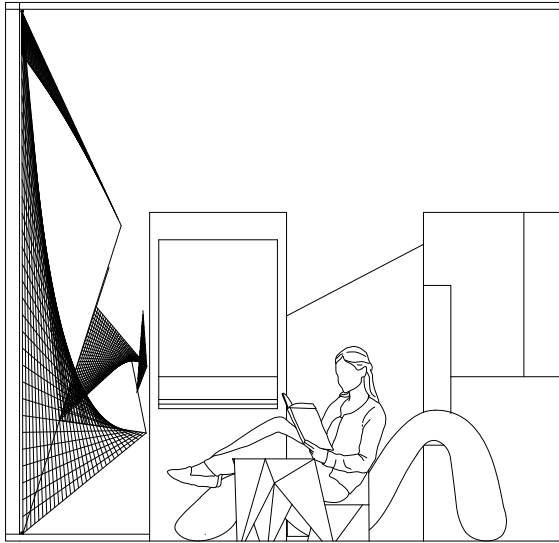

# Project 3

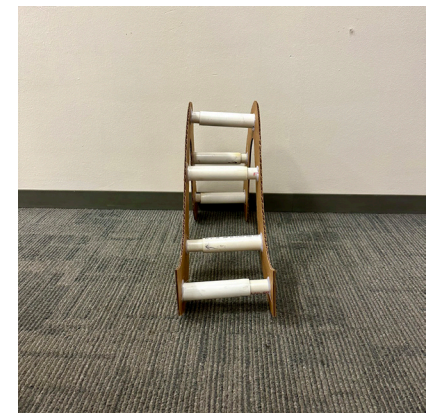

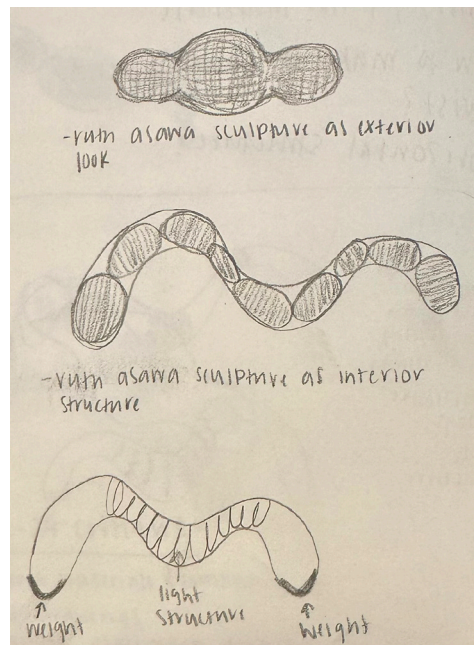
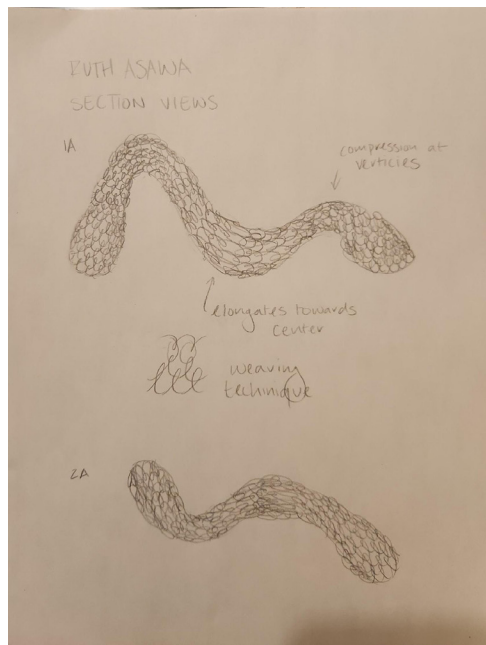

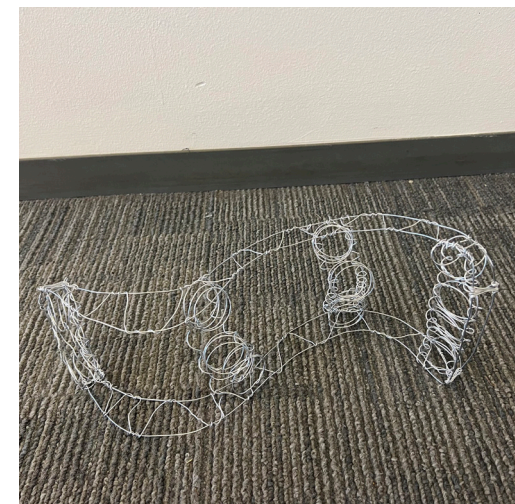
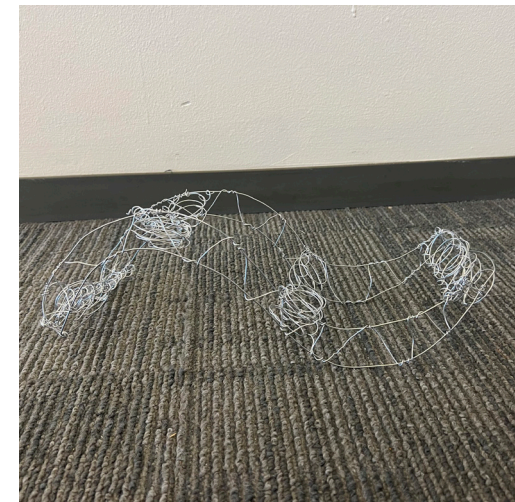
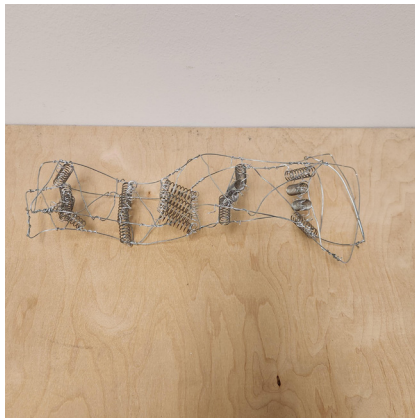



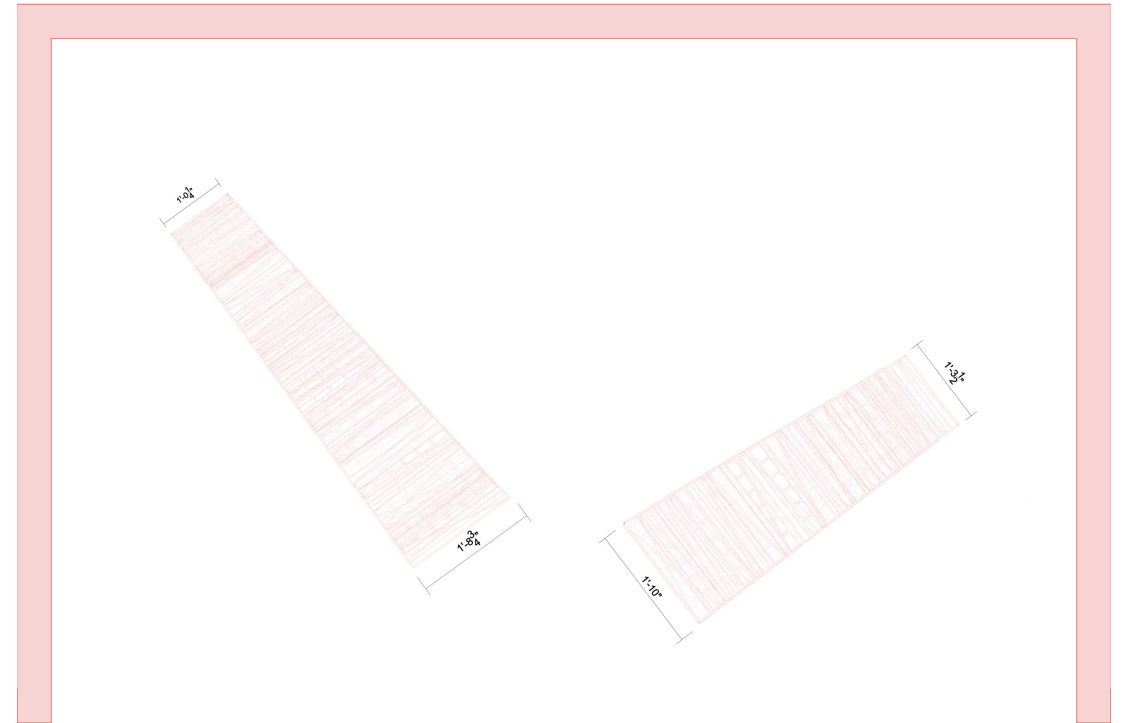

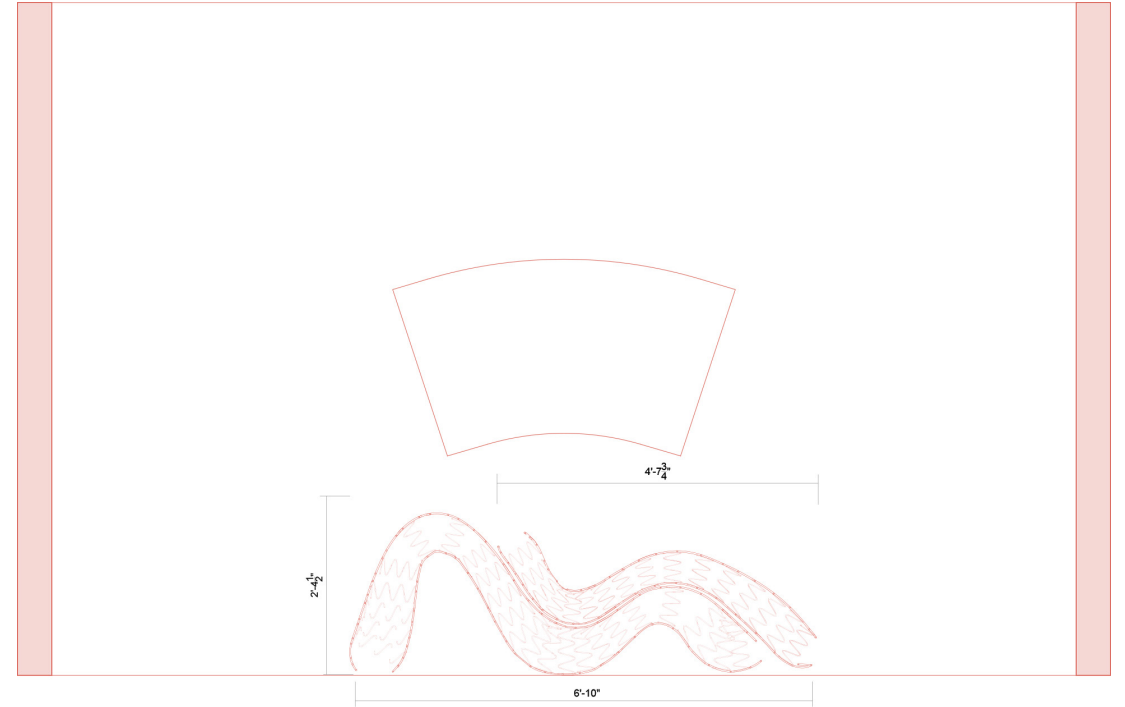
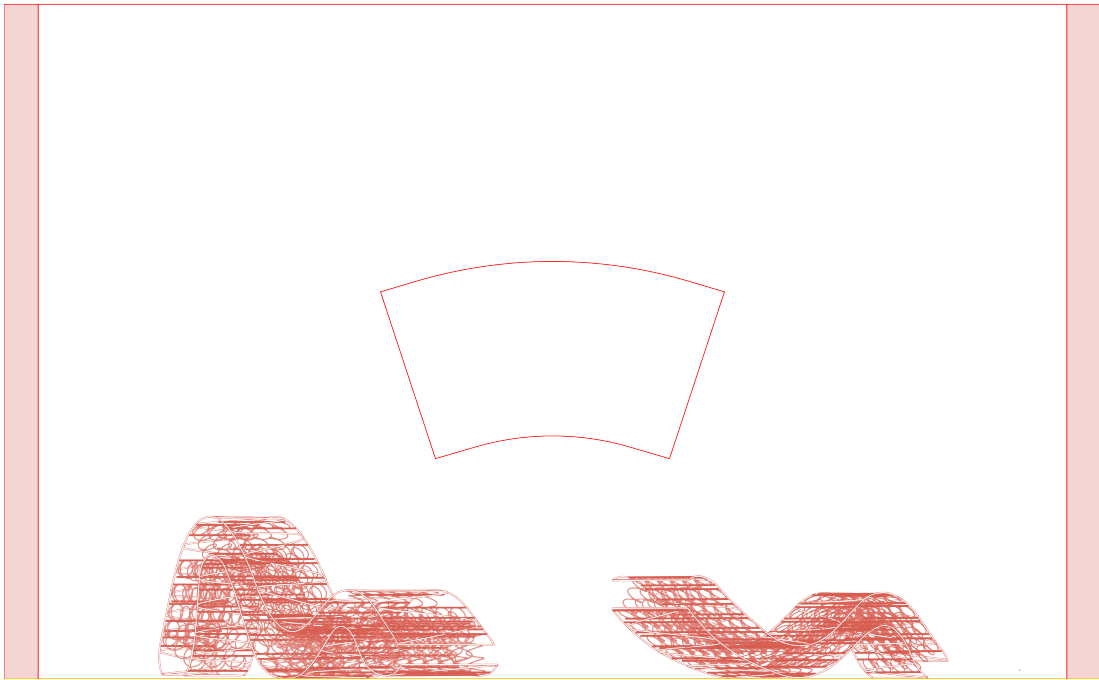

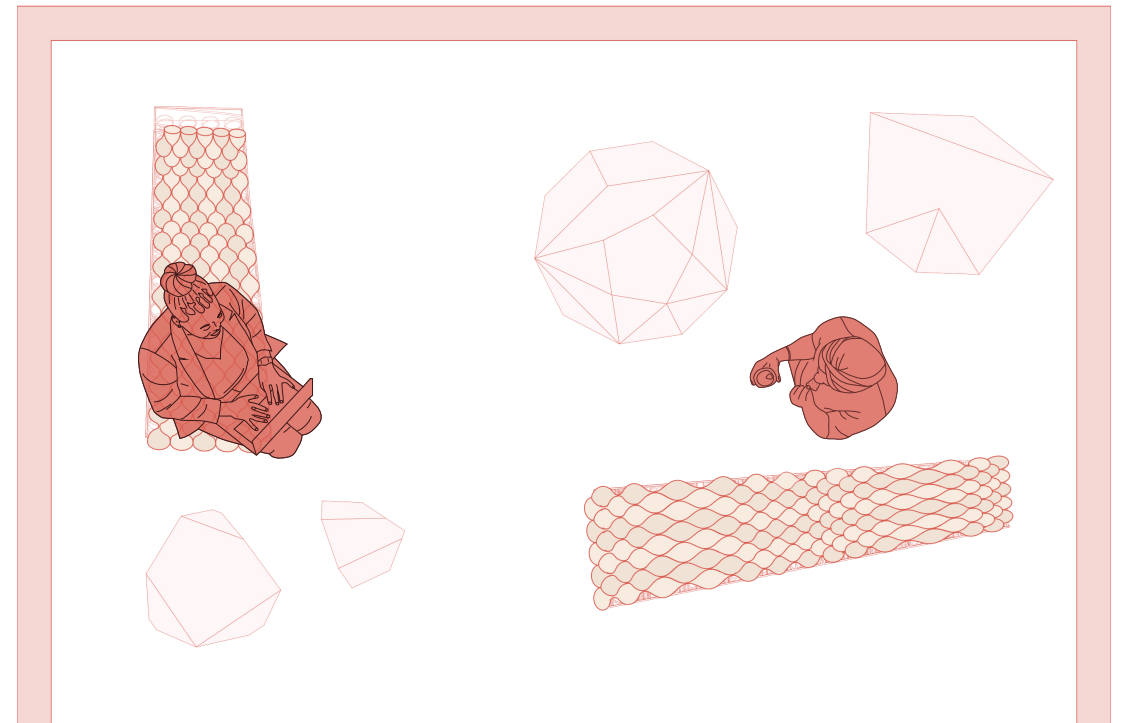
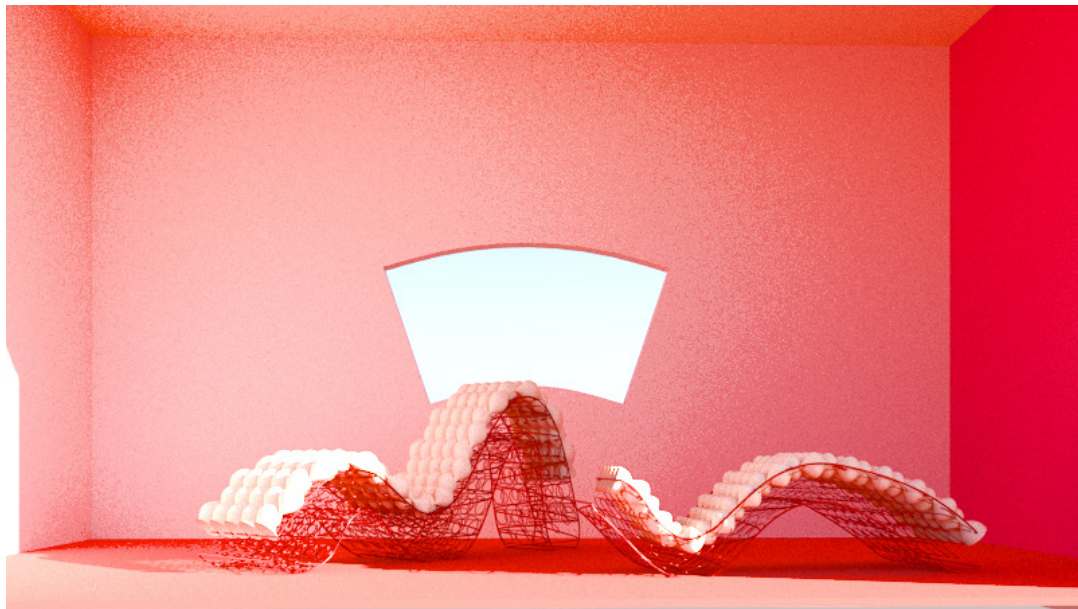

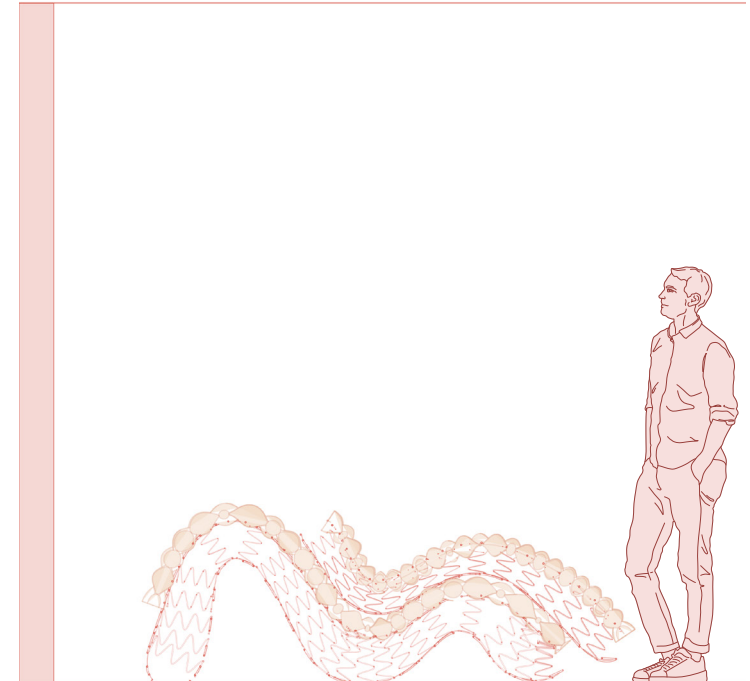
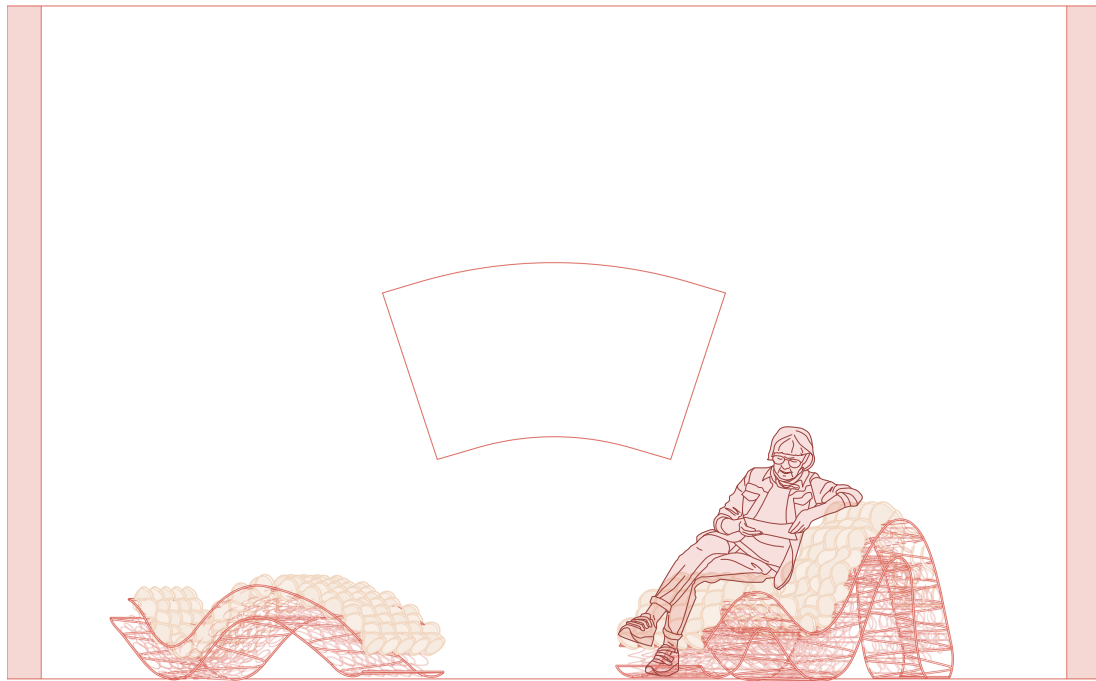

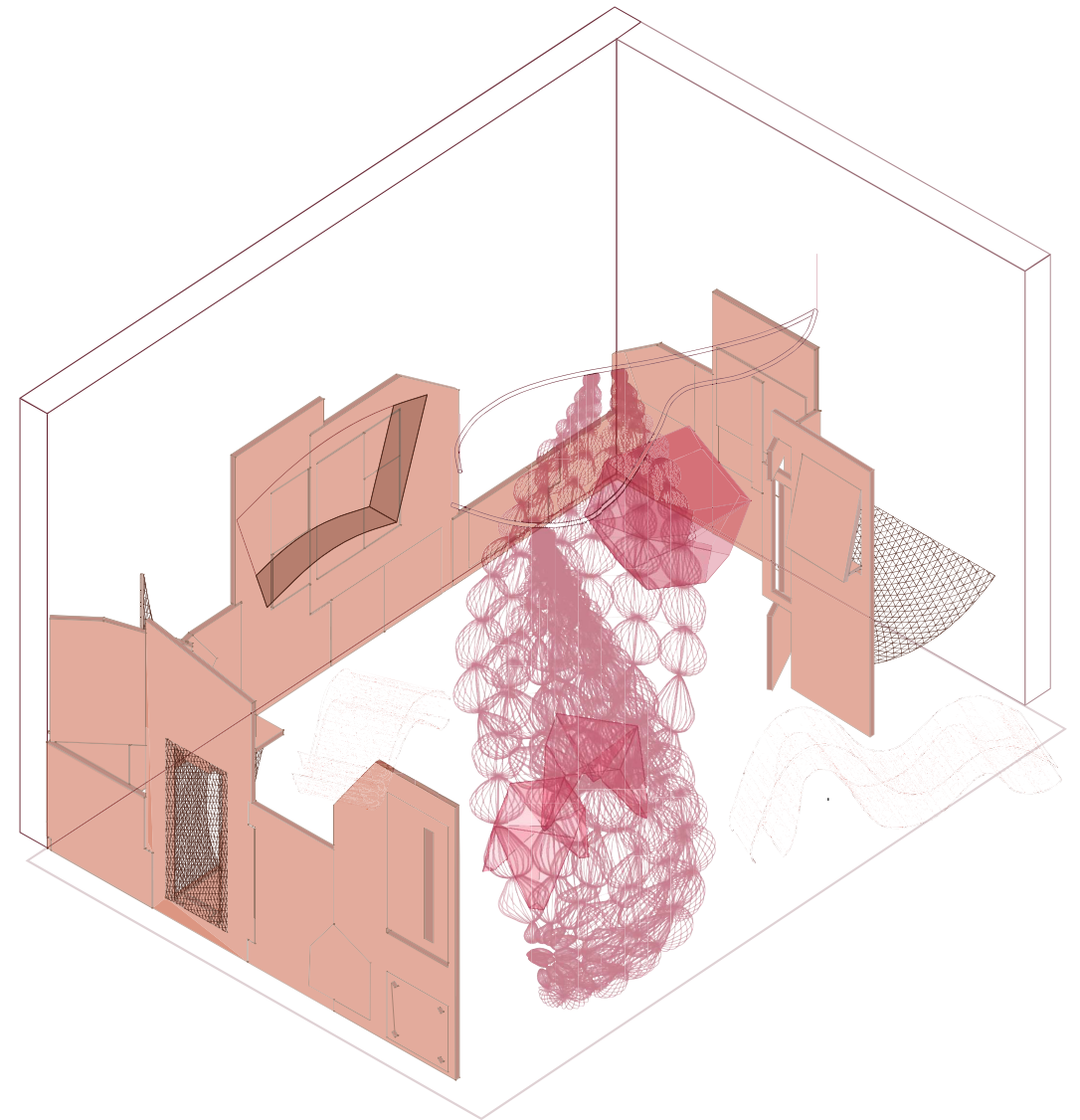
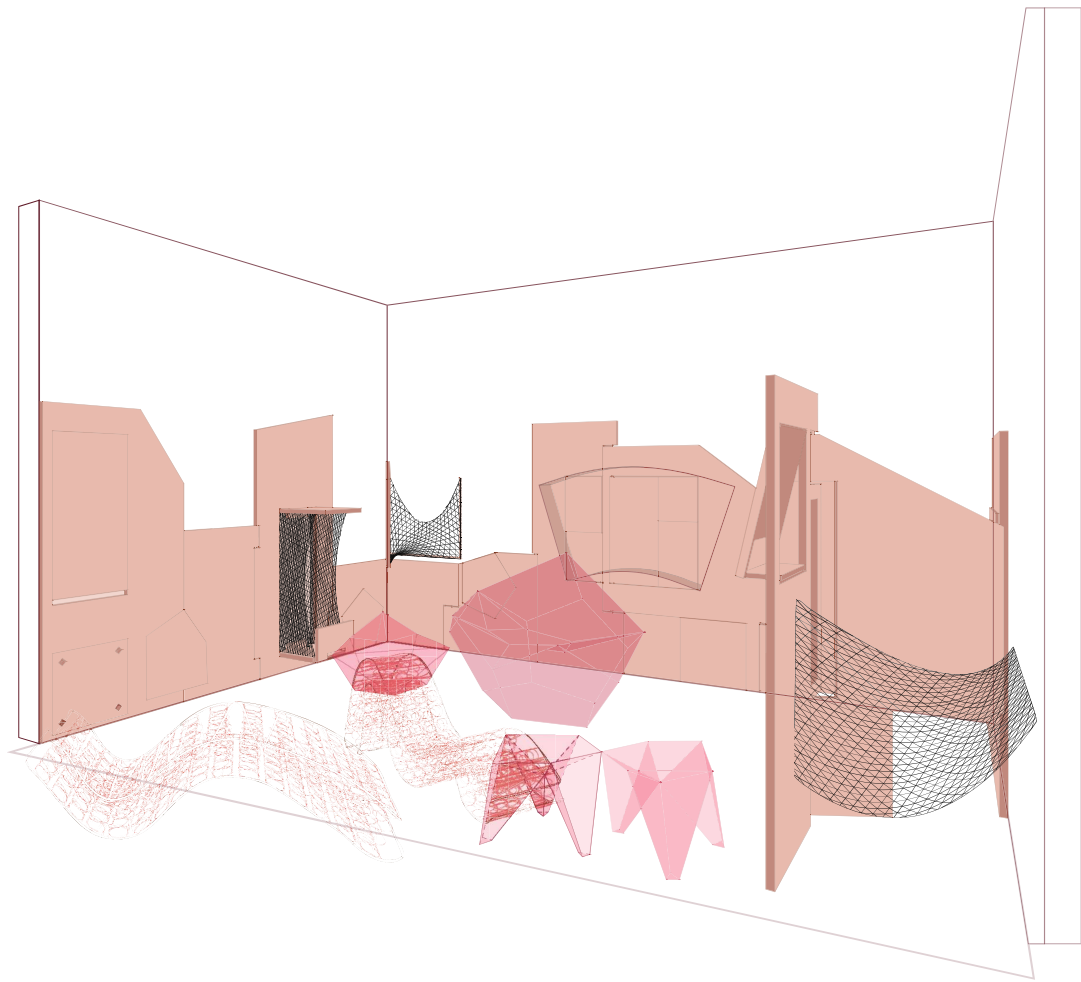

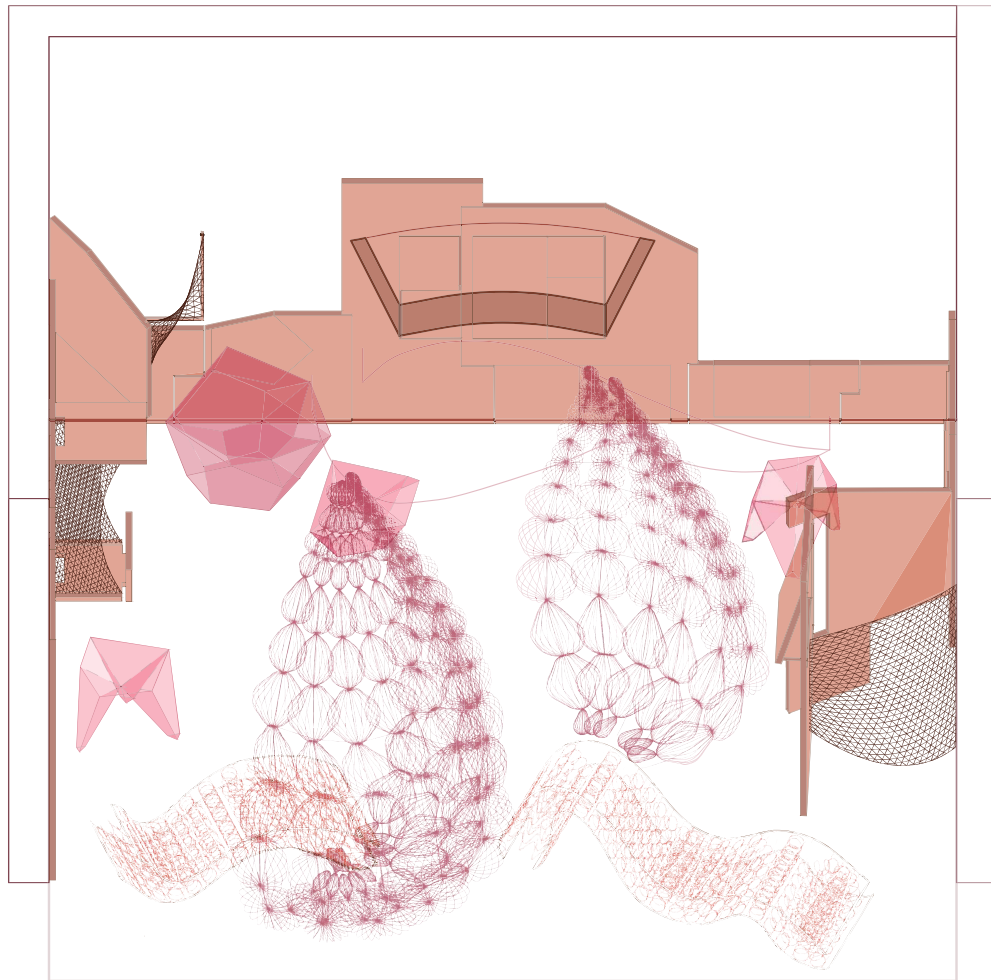

## Construction Manual

Angle Dimensions

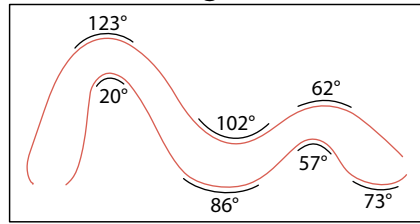

Materials:

7x - 1/4" Steel Rods

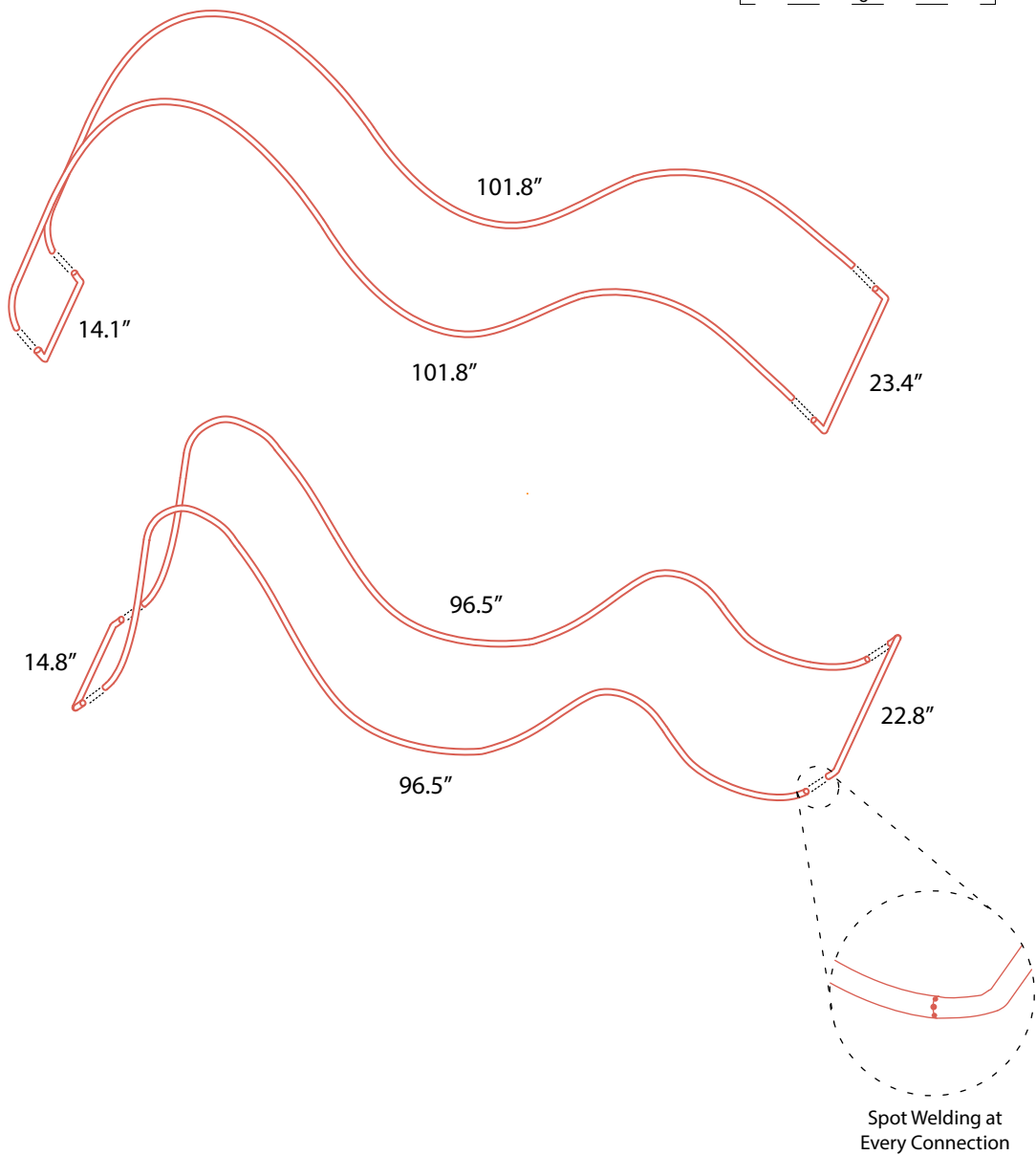
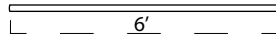

Materials:

15x - 1/8" Steel Rods

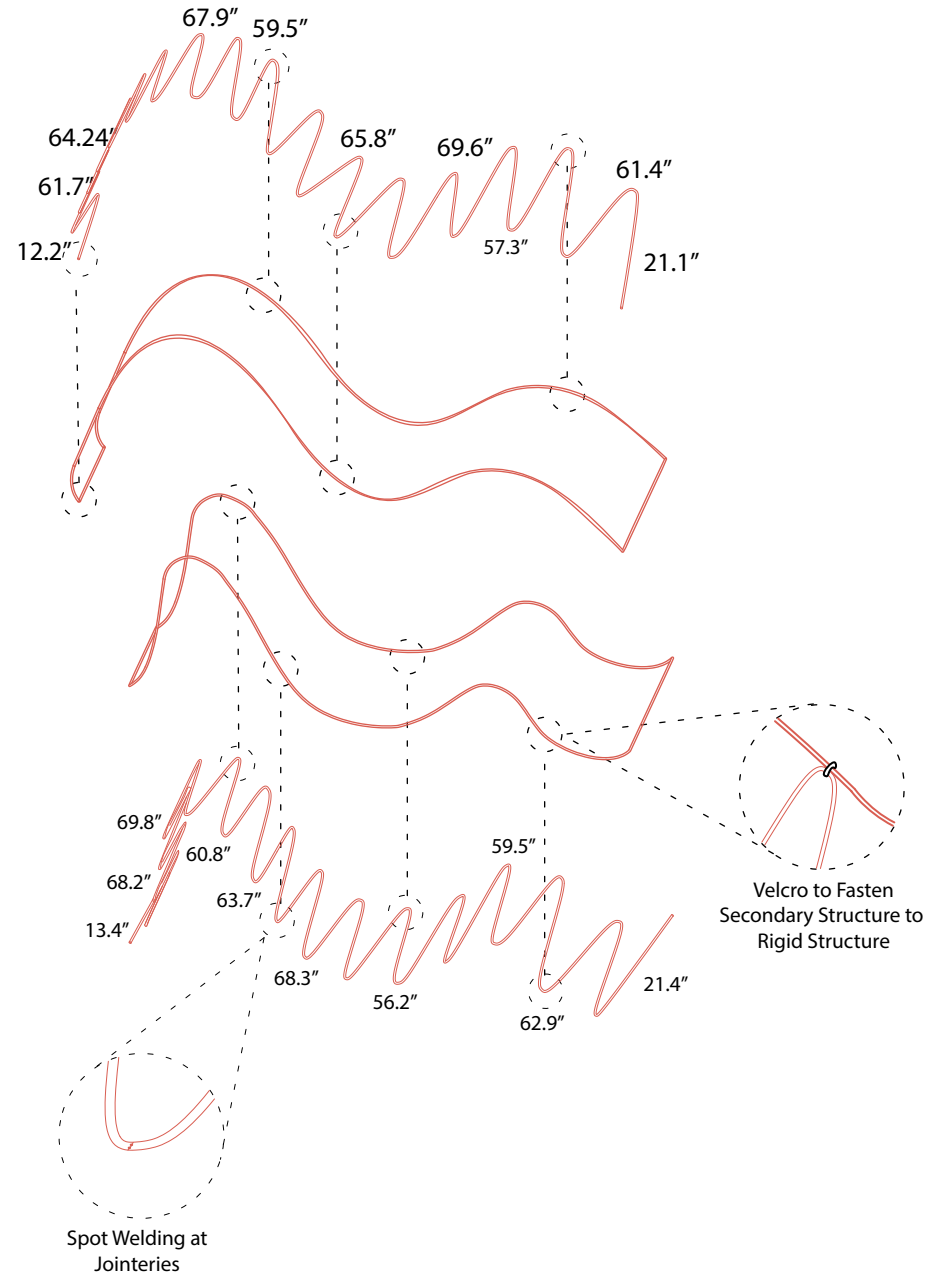
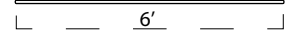





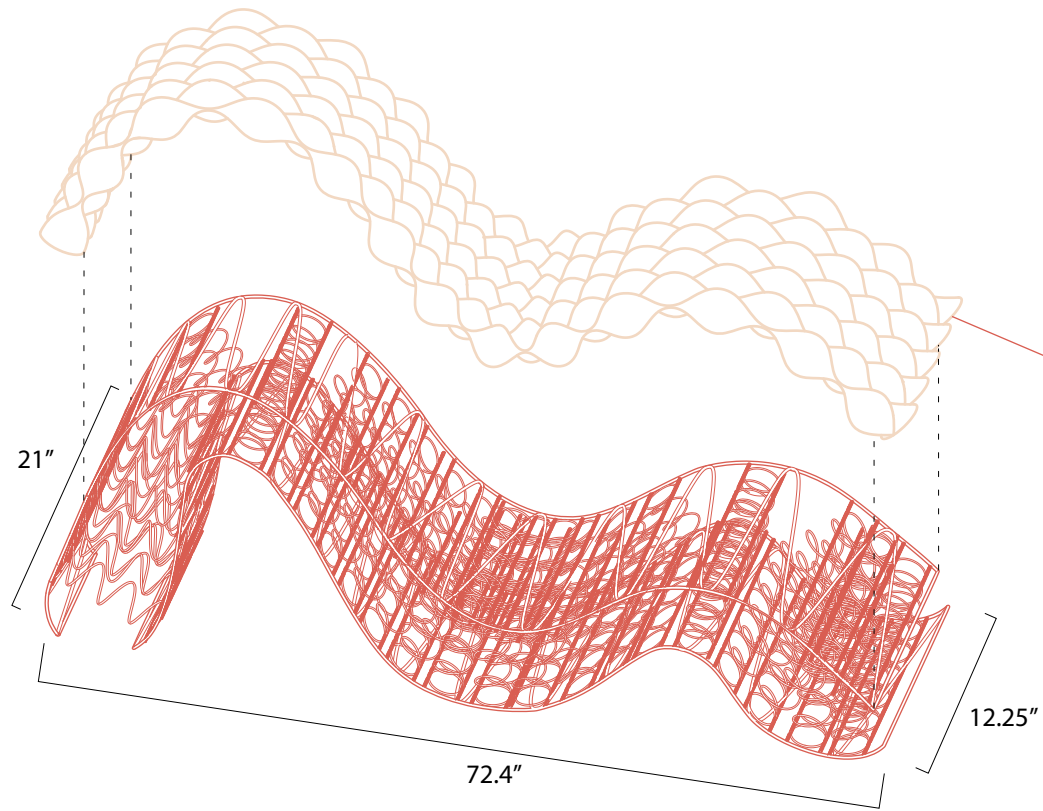

### Fabric Cushion Materials

10x Ivory  
Fabric strips

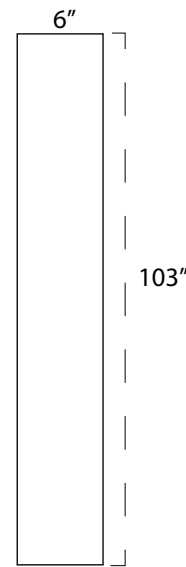

2x Long Yarn

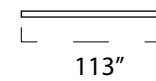

28x Small Yarn

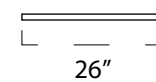

### How to Create Cushion

TOP VIEW

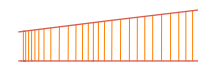

Tie short pieces of yarn equidistant between the two large yarn pieces, following plan shape. Cut off excess as needed. Leave 5" on each long yarn end.

SECTION VIEW

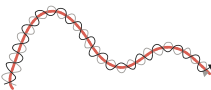

Weave ivory drapery fabric strips alternately in and out of yarn ladder structure.

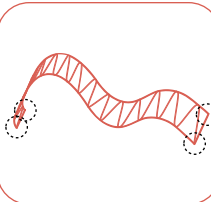

Knot the four yarn ends of the cushion onto corners of the rigid structure.

Angle Dimensions

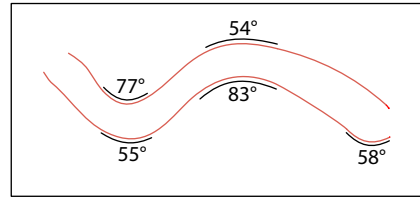

Materials:

6x - 1/4" Steel Rods

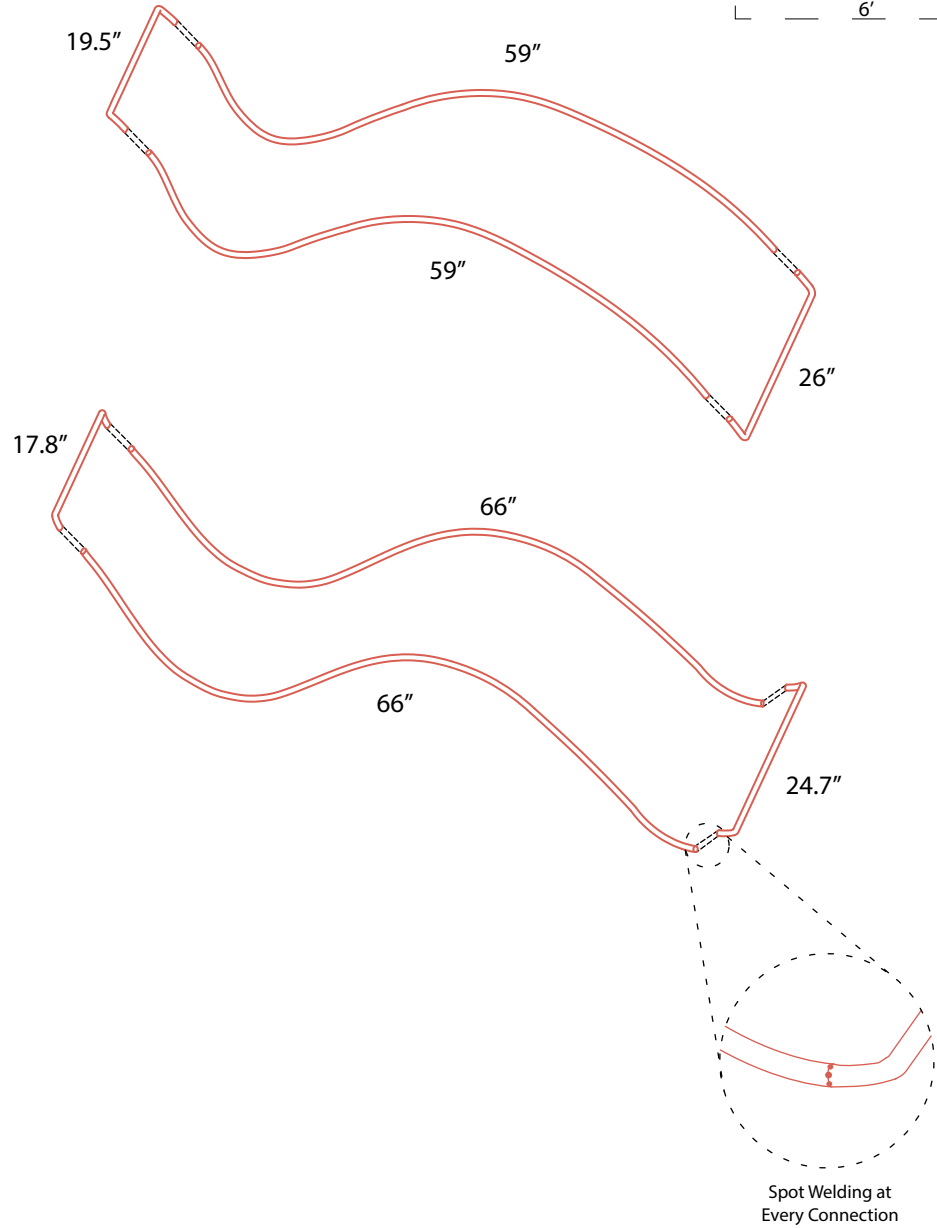
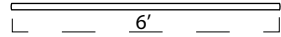

Materials:

11x - 1/8" Steel Rods

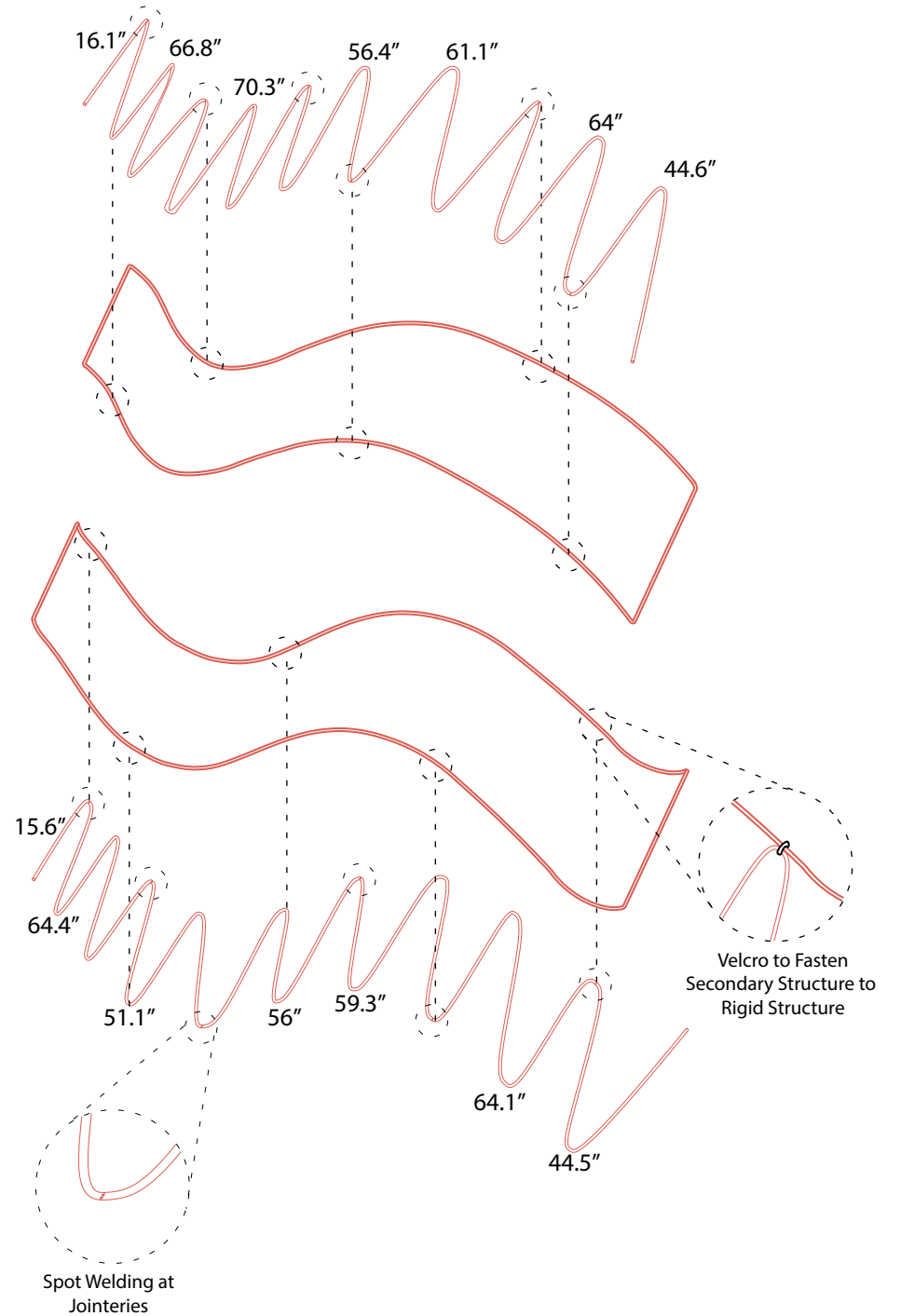
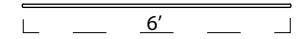

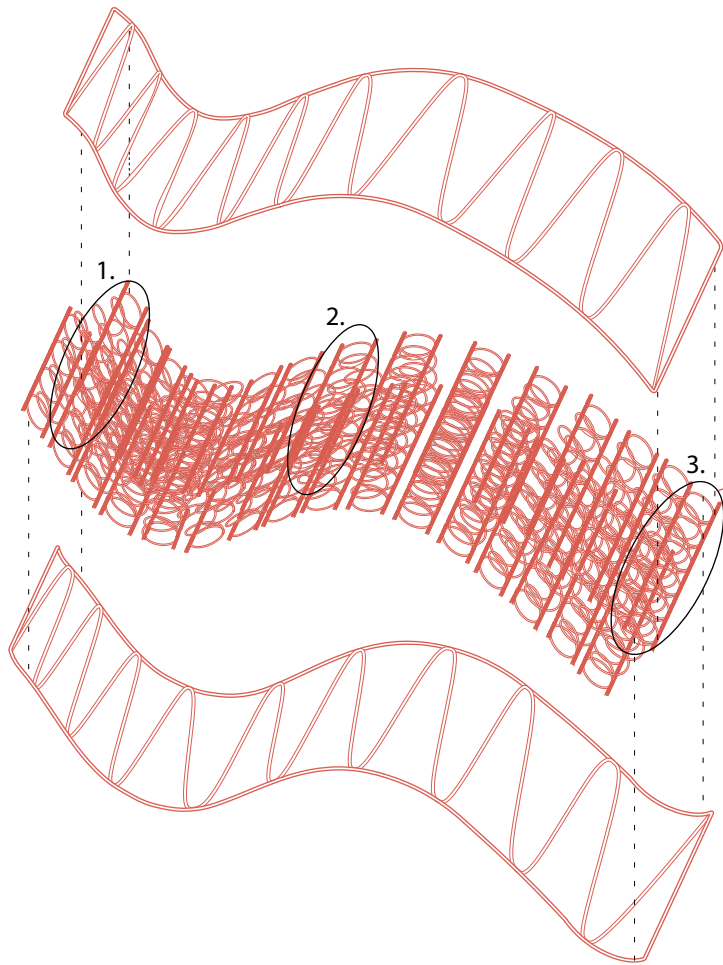

### Spring and Coil Length Guide

#### 1. Four Spring Rows

4x- 15" 0.25"

#### 2. Five Spring Rows

32x- 15-18" 0.25"

#### 3. Six Spring Rows

28x- 18-21" 0.25"

86x- 5" 3"

Note:  
There are 7 rows of  
6 springs, 8 rows of  
5 springs, and 1 row  
of 4 springs. Plan  
determines length of  
the long coils joining  
the springs.

### How to Join Springs

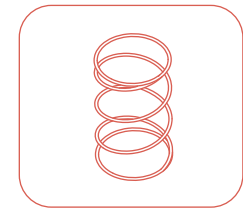

Gather number of  
springs per row

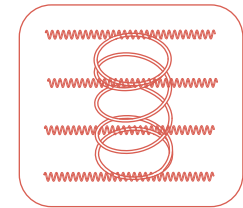

Twist Coils onto  
Springs-- two on  
top, two on  
bottom

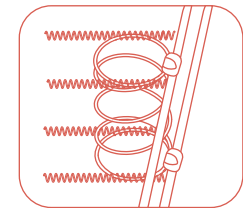

Once coils are  
joined, attach to  
structure with  
upholstery clips

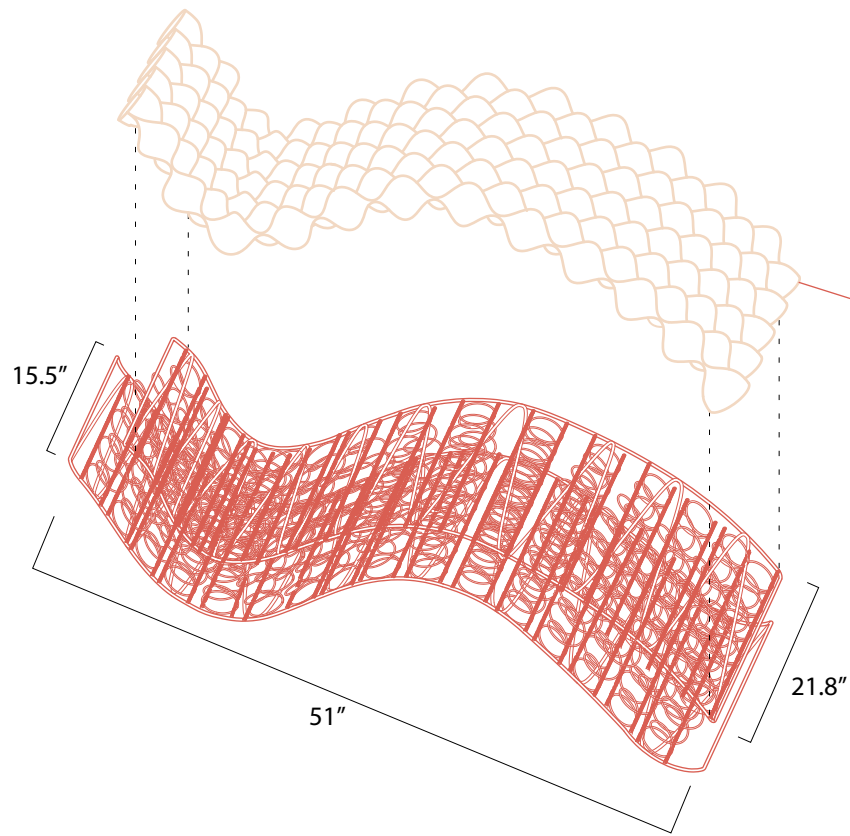

### Fabric Cushion Materials

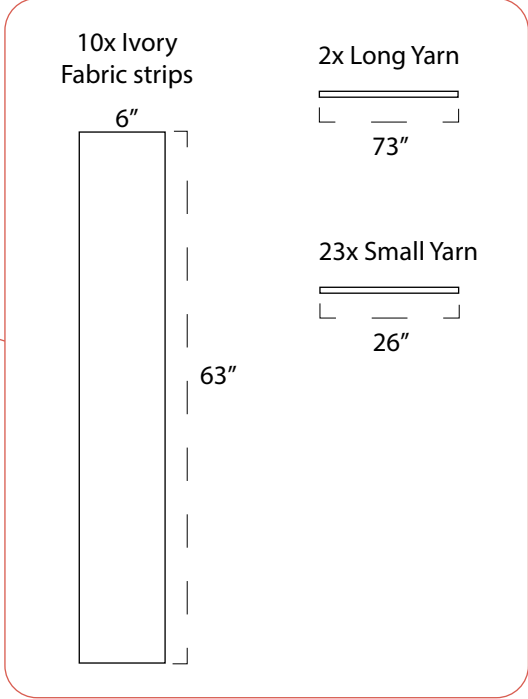

### How to Create Cushion

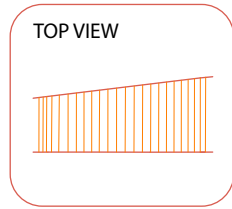

Tie short pieces of yarn equidistant between the two large yarn pieces, following plan shape. Cut off excess as needed. Leave 5" on each long yarn end.

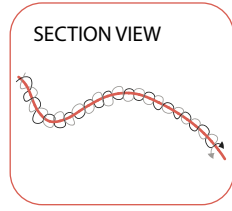

Weave ivory drapery fabric strips alternately in and out of yarn ladder structure.

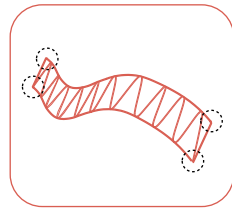

Knot the four yarn ends of the cushion onto corners of the rigid structure.

