

T

M

B

DOSSIER DE COLLECTION

THOMAS MORINEAU BARTHELEMY

La Taulo e l'Oustau

GESTE.S
a.s.d



Maquette conceptuelle - Photo : Geste.s ©

La Taulo e l'Oustau

Au bout du corridor tombé dans la pénombre,
La salle maîtresse de la maison,
Coincée dans un temps dont seule l'usure des choses,
Permet d'en saisir la sagesse,
L'Ousta u.

Entre maison et cour, elle fait transition
On y mange, on y rit, on s'y oublie, on la vit.
Sombre au sol, terreux jusqu'à son seuil
Le sol provençal s'exprime.
Point de faste ici, le terroir brut.
Le temps s'étire, la fumée masque
Toutes traces laissées dans la lumière se mêlent.
Le noir s'éclaire, les textures dialoguent.
Terre, bois, et pierre, un paysage se forme.
On y retourne, un jour.
Ouvrte à tout venant, elle invite à la pause.
Solide, ancrée dans la terre provençale,
Elle réchauffe, s'anime et se souvient
D'un temps où elle était tout.
La Taulo.

Pas de chichis ici, les petites mains s'affairent.
La paillasse épaisse accueillant les produits,
Supporte Lou Trissadou*, la Dougo* et Lou Sau Trisso*.
L'Òli* qui rit est prête, à grande brassée de pilon,
À sortir son Aiòli*, celle de la liberté.
Les Commis.

Sent lis aiet ici !

Lou Trissadou - Le mortier
Lou Dougo - La cruche
Lou Sau Trisso - le sel égrugé
l'òli - l'huile
l'Aiòli - l'aioli
Sent lis aiet ici - ça sent l'ail ici

TMB

THOMAS MORINEAU BARTHELEMY

Architecte HMONP
Scénographe
Designer

L'APPRENTISSAGE DE L'EXPRESSION DU GESTE

Geste.s est une plateforme interdisciplinaire fondée en 2022 par Thomas Morineau Barthelemy, portée par les matérialités brutes et la mise en avant des gestes artisans, qui agit à différentes échelles, du bâtiment vers l'objet et vice versa.

Geste.s cherche à concevoir des espaces, des pièces de mobilier et des objets sincères, authentiques, frugaux, vivants et sans artifices. Tissant un lien durable avec les artisans qui participent aux projets de l'agence, nous pensons qu'un projet, quelle que soit son échelle, se conçoit du geste vers la conception, en allers-retours itératifs entre celui qui fait et celui qui dessine.

La mise en avant de ces gestes artisans s'accompagne d'une réflexion sur la matière elle-même.
D'où vient-elle ?
Que représente-t-elle à l'échelle du terroir ?
Quelles sont ses propriétés intrinsèques ?
Comment représenter cet état naturel et l'appliquer à nos projets avec les standards attendus d'usage et d'entretien ?

Ces questions sont au cœur de l'identité de geste.s, avec le souci constant de proposer à nos clients une approche sensible, écologique et honnête pour une expérience brute, sans détours.

The learning of gesture expression

Geste.s is an interdisciplinary design platform built on a deep respect and love for raw materials and artisanal craft. We seek to work across multiple scales to create spaces, furniture and objects that are sincere, authentic, frugal, straightforward and inherently alive.

Craft is crucial: we build durable bonds with the craftspeople with whom we work, and believe that a project, regardless of its scale, must be from the very start an iterative back-and forth between those who make and those who design.

Our emphasis on craft is accompanied by deep reflection on the choice and qualities of materials. Where (and how) are they sourced and what meaning do they hold in their local region, community and culture? What are their intrinsic properties, and thus what design potential do they offer? Most importantly, how can we capture their natural essence and apply it in our projects, while meeting clients' needs for use and care ?

Geste.s was founded in 2022 by Thomas Morineau Barthelemy, a licensed architect (HMNOP, Paris-Malaquais 2017) who gained his initial experience on large-scale, urban projects in Japan, Switzerland and France. While the transition to design may seem a leap, for TMB the change in scale has an inherent logic- well-designed objects, like buildings, possess architectural structure that is a function of the inherent properties of their materials and techniques of fabrication.

Our pledge to clients - our "geste" - is to strive to unite design, materials and craft to create work that is unique, honest, ecologically sustainable and timeless, without detours or concessions.



Photo : Cécile Bortoletti ©

LA TAULO E L'OUSTAU

Une collection de geste.s par Thomas Morineau Barthelemy
2024

Focalisant son attention sur l'assemblage bois/grès, la première collection en autoédition La Taulo e l'Oustau de Thomas Morineau Barthelemy nous interpelle sur notre relation à l'objet, en mettant au premier plan la réalité constructive de ses meubles.

En créant une passerelle entre la matière brute et nos intérieurs contemporains, l'agence cherche à redonner du sens à l'acte de consommer en mettant en avant les origines de l'objet et en laissant la matière s'exprimer pleinement.

*« Le beau ne se trouve pas dans les objets ;
il est dans la nuance subtile de la pénombre,
dans le jeu du clair et de l'obscur qui se produit de leur assemblage »*

Junichirô Tanizaki, L'éloge de l'ombre
Trad. R.Sieffert, Verdier, 1978

Largement inspirée par les voyages en Asie et notamment au Japon de TMB, la collection La Taulo e l'Oustau repose sur 3 piliers fondateurs de cette philosophie esthétique orientale :

Le Wabi, la simplicité tranquille
Le Sabi, la patine du temps
Et l'Iki, l'art de la mesure.

Ces objets, frugaux dans leur conception et sincère dans leur construction se vantent de leur simplicité qu'ils expriment sans artifices. Sans clous, sans vis ou presque et réduisant au maximum l'utilisation de produits chimiques dans les étapes de leur fabrication, ils tendent à une neutralité d'impact environnemental.

Ce choix implique un travail artisanal d'exception et une réflexion sur l'ensemble du processus, dès la conception, jusqu'à la fabrication. La Taulo e l'Oustau est un travail manifeste, cherchant à questionner la relation que l'on peut avoir à l'objet et à l'inscrire dans un contexte environnemental propre à notre époque, en poussant le plus loin possible, le travail de mise en avant de la matière dans sa forme brute, subissant le moins de transformation possible, pour en sublimer ses caractéristiques.

La collection se compose d'une table basse, d'un guéridon, d'une suspension et d'une applique murale.

La table basse – la Taulo, ainsi que le guéridon - la Cabeç, sont accompagnés de leur boîte de transport sur mesure. Hommage à l'origine du Mobilier National, ces boîtes racontent la mobilité des meubles. Elles se marquent, s'usent durant les transports, et expriment ainsi le souvenir de ces mobilités tout en permettant une réutilisation en tant que meuble à part entière. Elles font partie intégrante de la collection, la Taulo e l'Oustau.

La Taulo e l'Oustau Collection, Studio Shots
Photo : geste.s ©

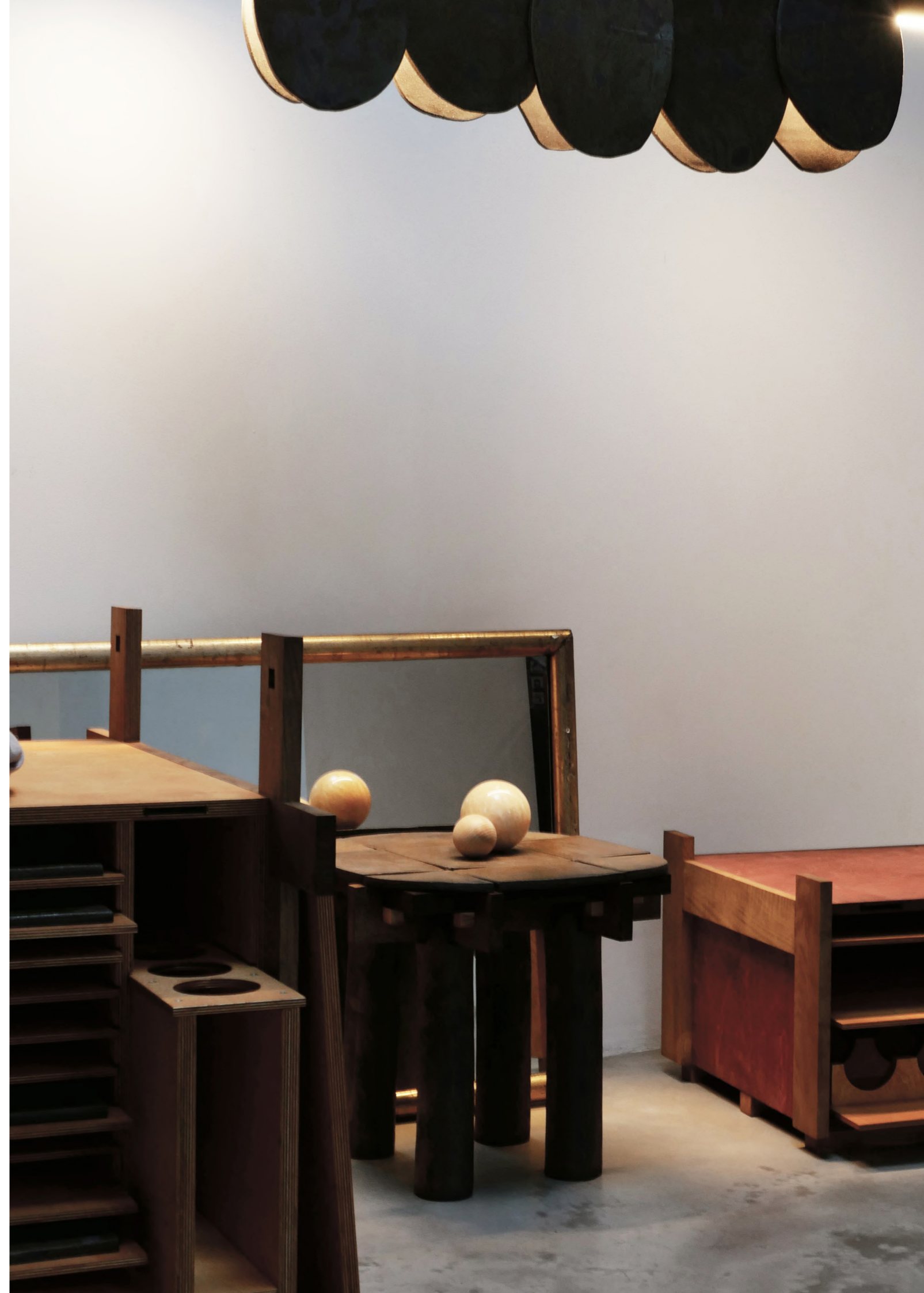

LA TAULO E L'OUSTAU

A furniture collection by geste.s founded by Thomas Morineau Barthelemy
2024

Focusing on the wood/clay assembly, the inaugural self-published collection "La Taulo e l'Oustau" by Thomas Morineau Barthelemy prompts us to reflect on our relationship with objects, highlighting the constructive reality of its furniture.

By bridging the gap between raw material and our contemporary interiors, the agency aims to bring meaning back to consumption by emphasizing the origins of the object and allowing the material to fully express itself.

Largely inspired by Thomas Morineau Barthelemy's travels in Asia, particularly in Japan, "La Taulo e l'Oustau" collection is built on three foundational pillars of this Eastern aesthetic philosophy :

*Wabi: the quiet simplicity
Sabi: the patina of time
Iki: the art of measure*

These objects, frugal in their design and sincere in their construction, boast their simplicity without artifice. Without nails, screws, or almost any chemical products in their manufacturing process, they strive for minimal environmental impact.

This choice entails exceptional craftsmanship and a thoughtful approach throughout the entire process, from conception to fabrication. "La Taulo e l'Oustau" is a manifesto, seeking to question the relationship we have with objects and embed them within an environmental context relevant to our time, pushing the boundaries of showcasing raw material with minimal transformation to highlight its characteristics.

The collection comprises a coffee table, a side table, a pendant light, and a wall sconce. The coffee table -

"La Taulo", and the side table - "La Cabeç", are accompanied by their custom transport boxes. Paying homage to the origin of the National Furniture, these boxes narrate the mobility of furniture. They bear marks, wear during transportation, thus expressing the memory of these movements.

They are an integral part of the "La Taulo e l'Oustau" collection.

MOB001.B Kasagi, Studio Shots
Photo : Cécile Bortoletti ©



MOB001 . LA TAULO

Coffee table

Hand-glazed chamotted black clay, naturally stained ash wood, burned larch wood
 Custom finishes available upon request according to the La Taulo e l'Oustau collection color palette

H480xL1700xI1100mm
 Indicative dimensions due to the unique appearance of the clay feet.

Numbered piece, limited to 8 copies + 1 prototype
 Signed certificate of authenticity

Lead time: 14-16 weeks

2022

- 39 Black grog clay tiles - 19,5x19,5cm ①

Black clay with thick white grog
 Satin-finished clear glaze, sponge-textured
- Black stained wood structure - 164x104cm ②

Composed of 10 ashwood battens
 Each with a section of 2x3cm
 Joined with half-lap joints
- 5 ashwood main structure ③

Sanded ash wood
 Each with a section of 2x8cm
 Joined with half-lap joints and adjusted with wooden keys
- 10 pairs of ashwood keys ④

Sanded ash wood
 Adjustment for the flatness of the stained wood frame
- 6 raw black grog clay table legs - ø 8cm, height 37cm ⑤

Black clay with thick white grog
 Satin-finished clear glaze, sponge-textured
- 2 stone benches from Pont du Gard - 24x30x120cm - NOT INCLUDED ⑥

Block of stone from Pont du Gard, Occitanie region
 Hand-textured
 Underside grooves for installation support
- 3 x 2 perforated black clay bricks - 5.4x10.5x22cm - NOT INCLUDED ⑦

Black clay, Hand perforated

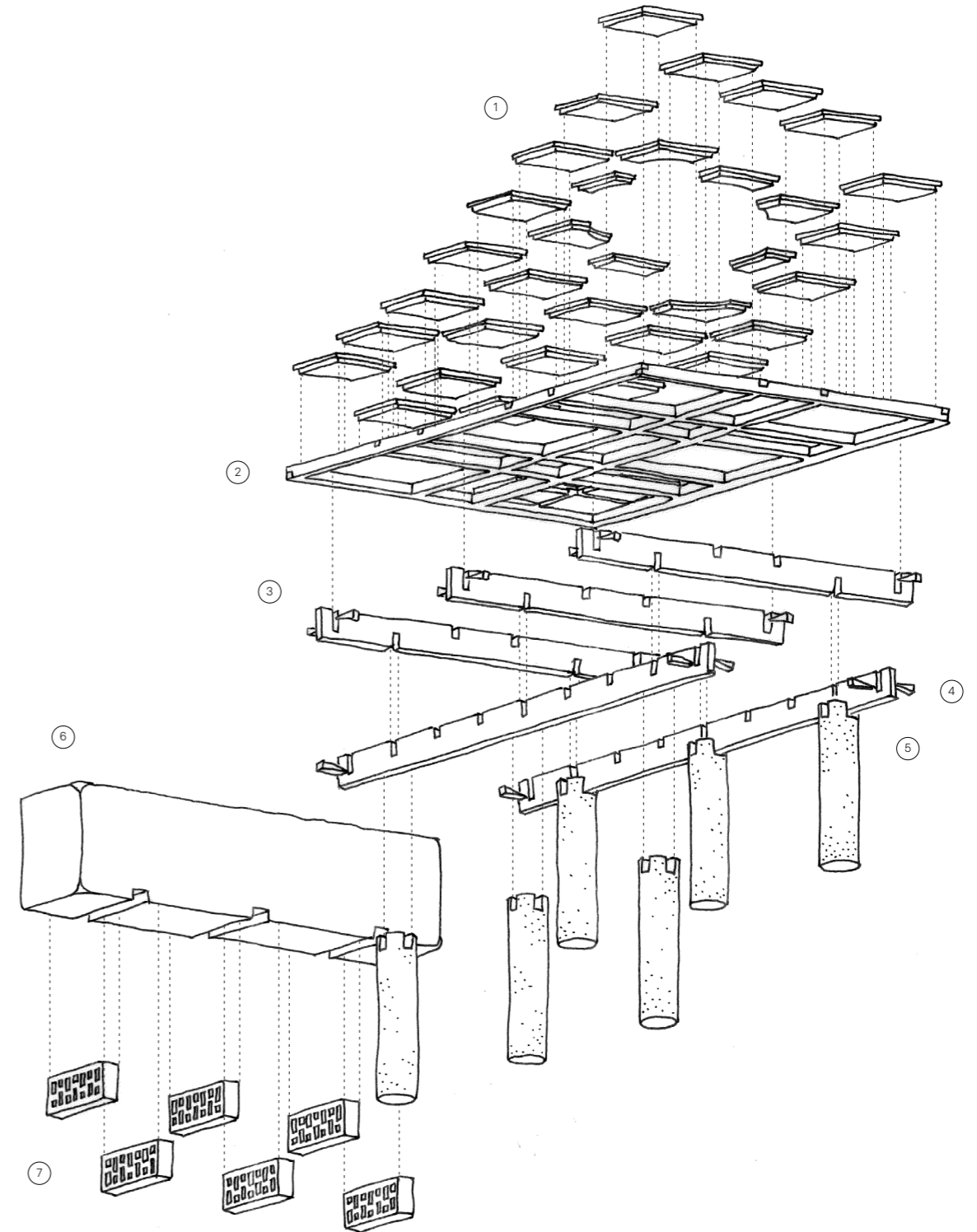



MOB001 La Taulo, Studio Shot
Photo : Geste.s ©



MOB001 La Taulo, Detail
Photo : Geste.s ©



MOB001 La Taulo, Exhibition Shot at Collectible Brussels
Photo : Camille Lemonnier ©



MOB001 La Taulo, Exhibition Shot at Collectible Brussels
Photo : Camille Lemonnier ©



MOB001 La Taulo, Showcased in "la Taulo e l'Oustau, la cuisine rêvée de Frédéric Mistral",
Design Parade Toulon 2022
Photo : Geste.s ©



MOB001 La Taulo, Detail
Photo : Geste.s ©



MOB001 La Taulo, Detail
Photo : Geste.s ©



MOB001 La Taulo, Showcased in "la Taulo e l'Oustau, la cuisine rêvée de Frédéric Mistral",
Design Parade Toulon 2022
Photo : Luc Bertrand ©

MOB001B . KASAGI

Transport Boxes . Dining table

Oiled Stained Ash, Stained Birch

Kasagi 1: H150xW1900xD1300mm

Kasagi 2: H790xL980x420mm

Table height : 750mm

Central structure : L980xl420mm

Numbered piece, limited to 8 copies + 1 prototype

Signed certificate of authenticity

Lead time: 14-16 weeks

2024

Front and Back Openings ①

Stained Birch Plywood A/AA Grade
Hidden openings with an Allen key

13 racks containing 39 Black grog clay tiles ②

Black clay with thick white grog
Satin-finished clear glaze, sponge-textured

8 raw black grog clay table legs rack ③

Black clay with thick white grog
Satin-finished clear glaze, sponge-textured

Wood structure Box ④

Stained Birch Ply wood

Wood structure of MOB001 La Tauro ⑤

Stained ash wood, sanded natural ash wood

Wood structure Box ⑥

Stained Birch Ply wood

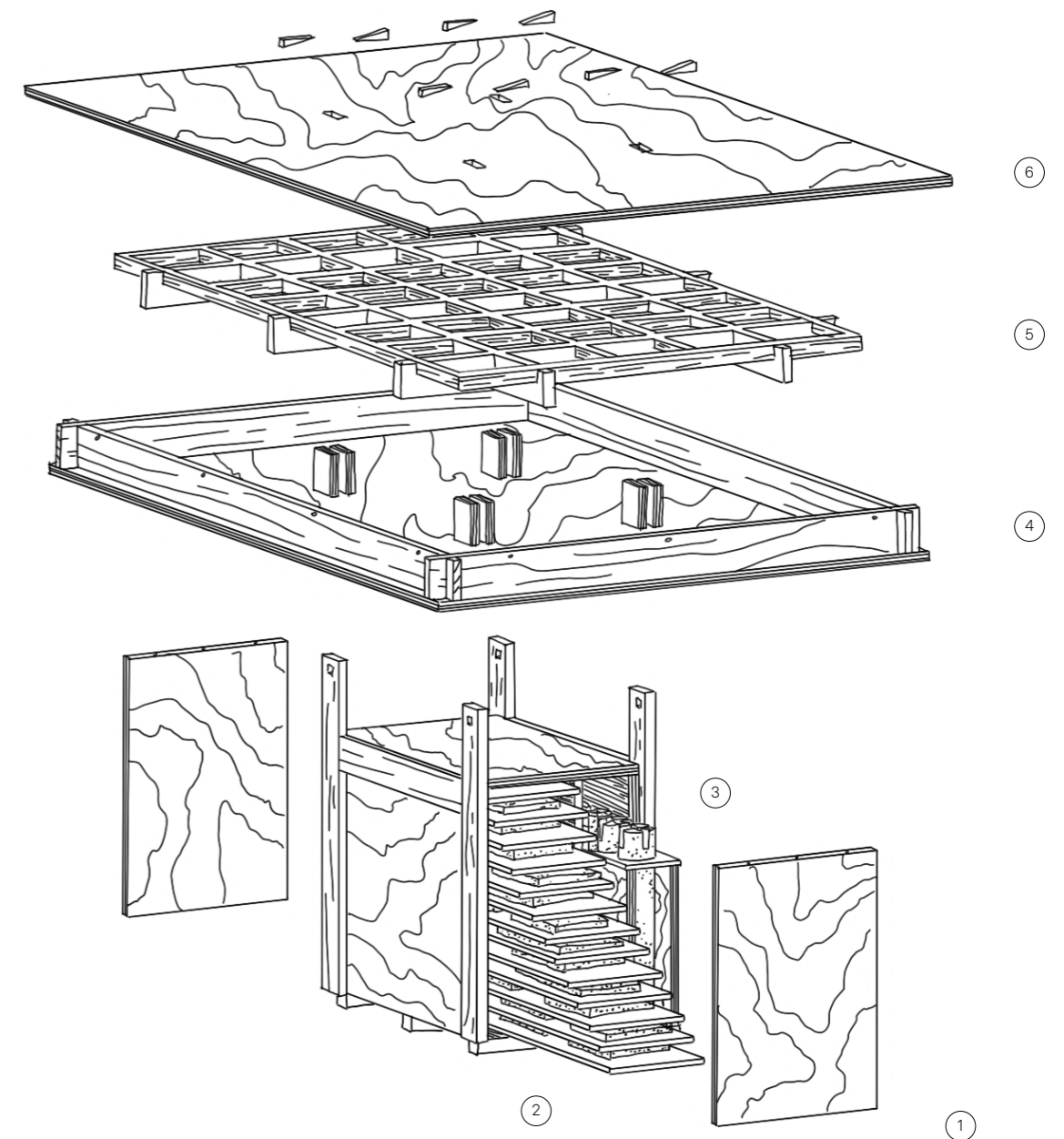



MOB001.B Kasagi, Studio Shot
Photo : Cécile Bortoletti ©



MOB001.B Kasagi, Lower part
Photo : Cécile Bortoletti ©

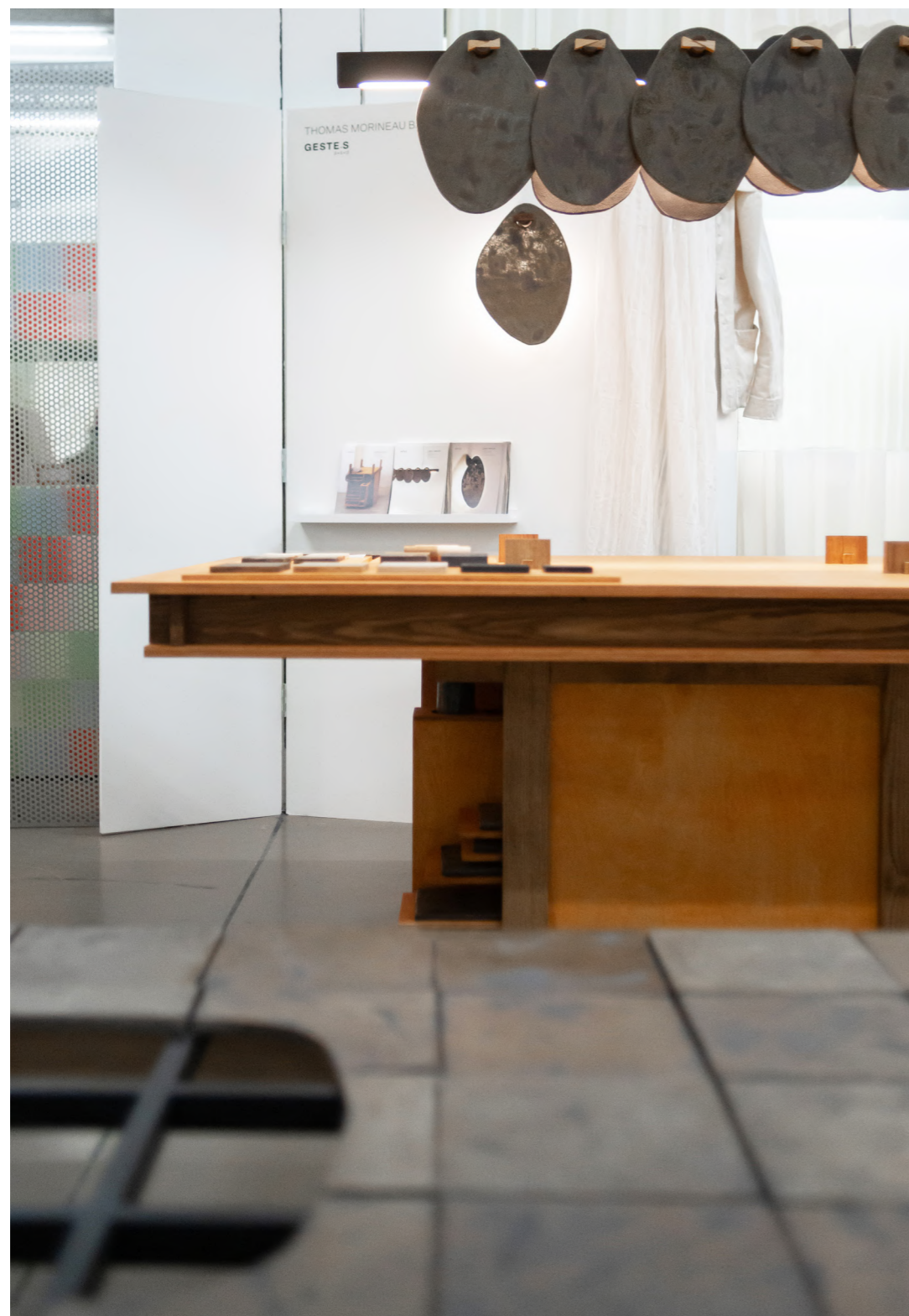

MOB001 La Taulo, in front of MOB001.B Kasagi, it's transport box, Exhibition Shot at Collectible Brussels
Photo : Camille Lemonnier ©



MOB001.B Kasagi, Zoom, Exhibition Shot at Collectible Brussels
Photo : Camille Lemonnier ©



MOB001.B Kasagi, Lower part detail on the MOB001 La Taulo feet storage, Exhibition Shot at Collectible Brussels
Photo : Camille Lemonnier ©

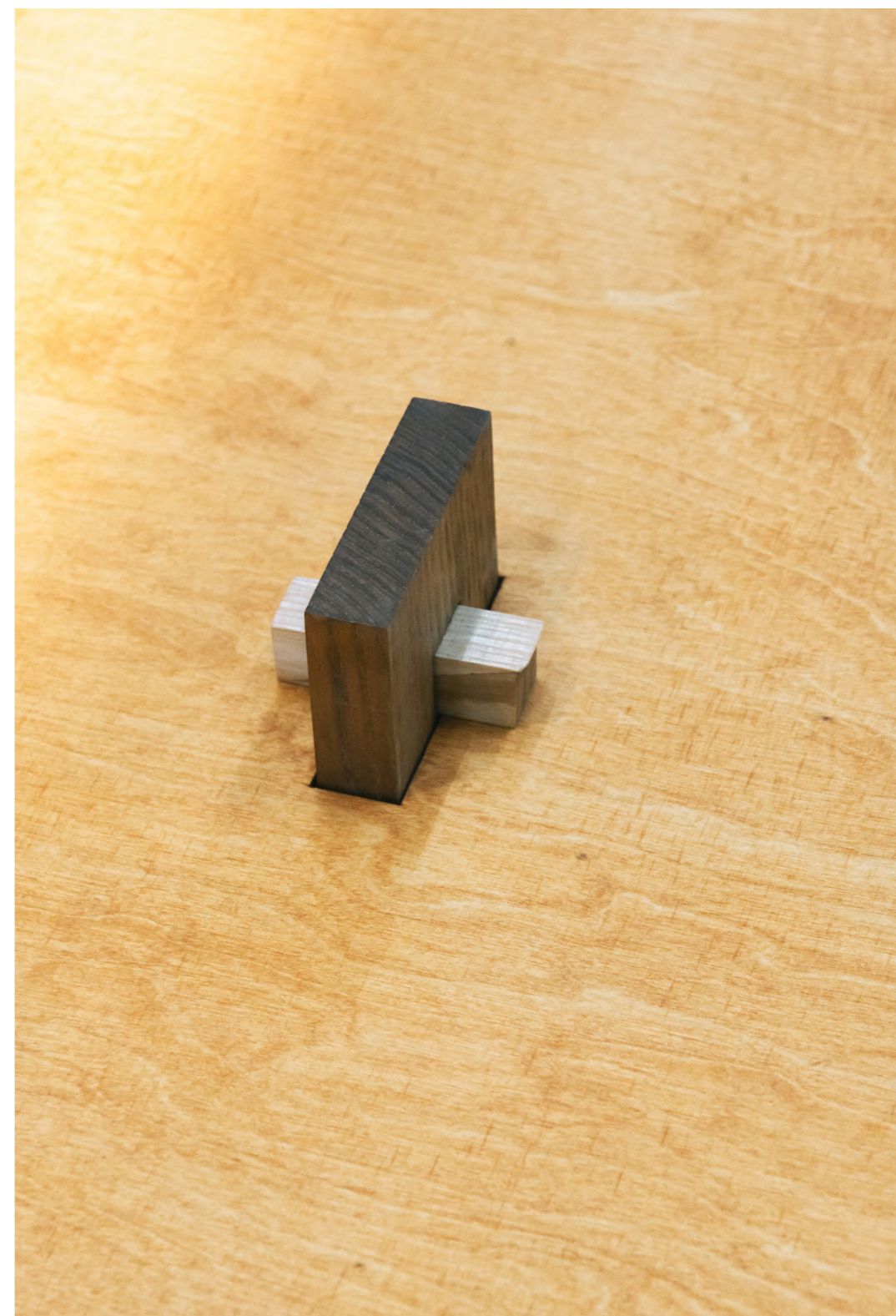

MOB001.B Kasagi, Zoom on the assembly wooden keys that unify the two parts
Photo : Camille Lemonnier ©

DOSSIER DE COLLECTION

MOB002 . LA CABEÇ

Side Table

Hand-glazed chamotted black clay, naturally stained ash wood, burned larch wood
Custom finishes available upon request according to the La Taule e l'Oustau collection color palette

H480xL480xI480mm
Indicative dimensions due to the unique appearance of the clay feet.

Numbered piece, limited to 8 copies + 1 Artist's proof
Signed certificate of authenticity

Lead time: 14-16 weeks

2023

4 raw black grog clay table legs - ø 8cm, height 37cm ①

Black clay with thick white grog
Satin-finished clear glaze, sponge-textured

4 ashwood main structure ②

Naturally stained ash wood
Each with a section of 2x8cm
Joined with half-lap joints and adjusted with wooden keys

8 pairs of wooden keys. ③

Sanded raw oak wood - Naturally Stained
Securing the clay plates.

Hand torched secondary structure ④

Composed of 10 ashwood battens
Each with a section of 2x3cm
Joined with half-lap joints

8 Black grog clay tiles ⑤

Black clay with thick white grog
Satin-finished clear glaze, sponge-textured

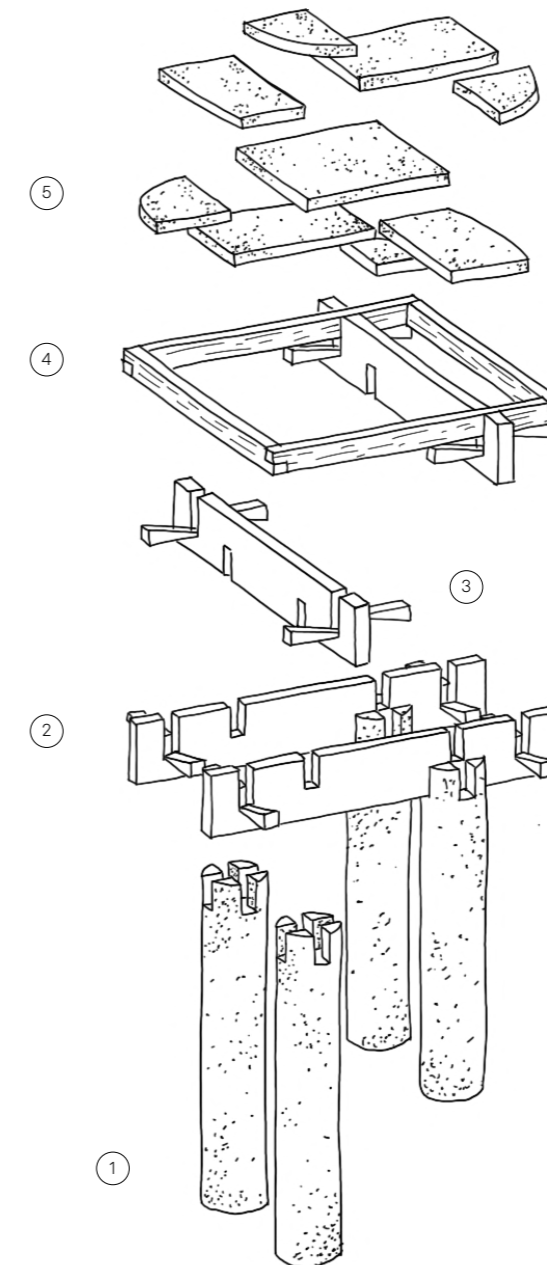



MOB002 La Cabeç, under LUM002 Pampille, Studio Shot
Photo : Cécile Bortoletti ©



MOB002 La Cabeç, Studio Shot
Photo : Cécile Bortoletti ©



MOB002 La Cabeç
Photo : Cécile Bortoletti ©



MOB002 La Cabeç, Mounting Process on top of the MOB002.B Hashira
Photo : Cécile Bortoletti ©



MOB002 La Cabeç, on top of its transport box, MOB002.B Hashira, Exhibition shot at Collectible Brussels
Photo : Cécile Rosenstrauch©



MOB002 La Cabeç, Exhibition Shot at Collectible Brussels.
Photo : Cécile Rosenstrauch ©

DOSSIER DE COLLECTION

MOB002B . HASHIRA

Transport Boxes . Side table

Oiled Stained Ash, Stained Birch

H400xW610xD570mm.

Numbered piece, limited to 8 copies + 1 prototype
Signed certificate of authenticity

Lead time: 10-12 weeks

2024

Front and Back Openings ①

Stained Birch Plywood A/AA Grade
Hidden openings with an Allen key

4 raw black grog clay table legs - ø 8cm, height 37cm ②

Black clay with thick white grog
Satin-finished clear glaze, sponge-textured

Wood structure rack ③

Stained ash wood and hand torched secondary structure
wooden keys

8 Black grog clay tiles ④

Black clay with thick white grog
Satin-finished clear glaze, sponge-textured

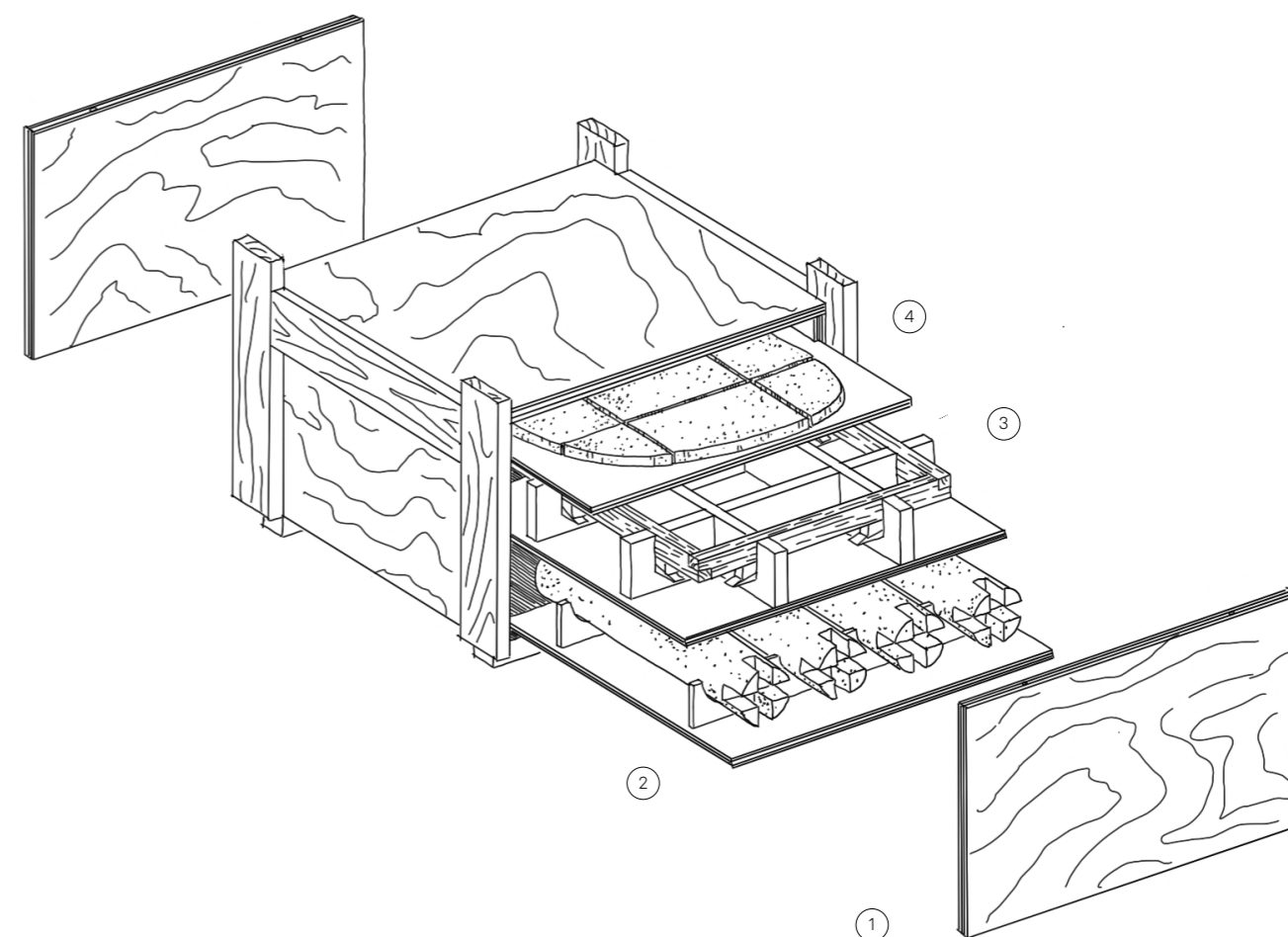



MOB002.B Hashira, closed
Photo : Cécile Bortoletti ©



MOB002.B Hashira, open
Photo : Cécile Bortoletti ©



MOB002.B Hashira, displaying the MOMB002 La Cabeç
Photo : Cécile Bortoletti ©



MOB002 La Cabeç, Mounting Process on top of the MOB002.B Hashira, its transport box
Photo : Cécile Bortoletti ©

DOSSIER DE COLLECTION

LUM002 . PAMPILLES

Pendent Light

Hand-glazed chamotted black clay, burned larch wood, naturally stained ash wood
Custom finishes available upon request according to the La Taulo e l'Oustau collection color palette

Dimmable LED 2700k

H400xL1350xP130mm
Indicative dimensions due to the unique appearance of the clay droplets.

Open collection
Signed certificate of authenticity

Lead time: 10-12 weeks

2023

Main beam - 1350x48x60mm	①
Hand-torched larch wood LED strip IP40 - 2700k - 1260mm - Dimmable 24v - 35w, detachable aluminum	
10 glazed chamotted clay plates - Approximately 400x200x10mm	②
Glazed PRNF clay with transparent glaze, sponged finish	
10 dowels - 110x30mm	③
Sanded raw oak wood - Naturally Stained Holding the clay plates	
10 pairs of wooden keys.	④
Sanded raw oak wood - Naturally Stained Securing the clay plates.	
Stainless steel wire - Maximum length 1000mm.	⑤
Suspension of the pendent light	
2 brass mounting brackets - diameter 40mm	⑥
Brass mounting bracket with brass screws	

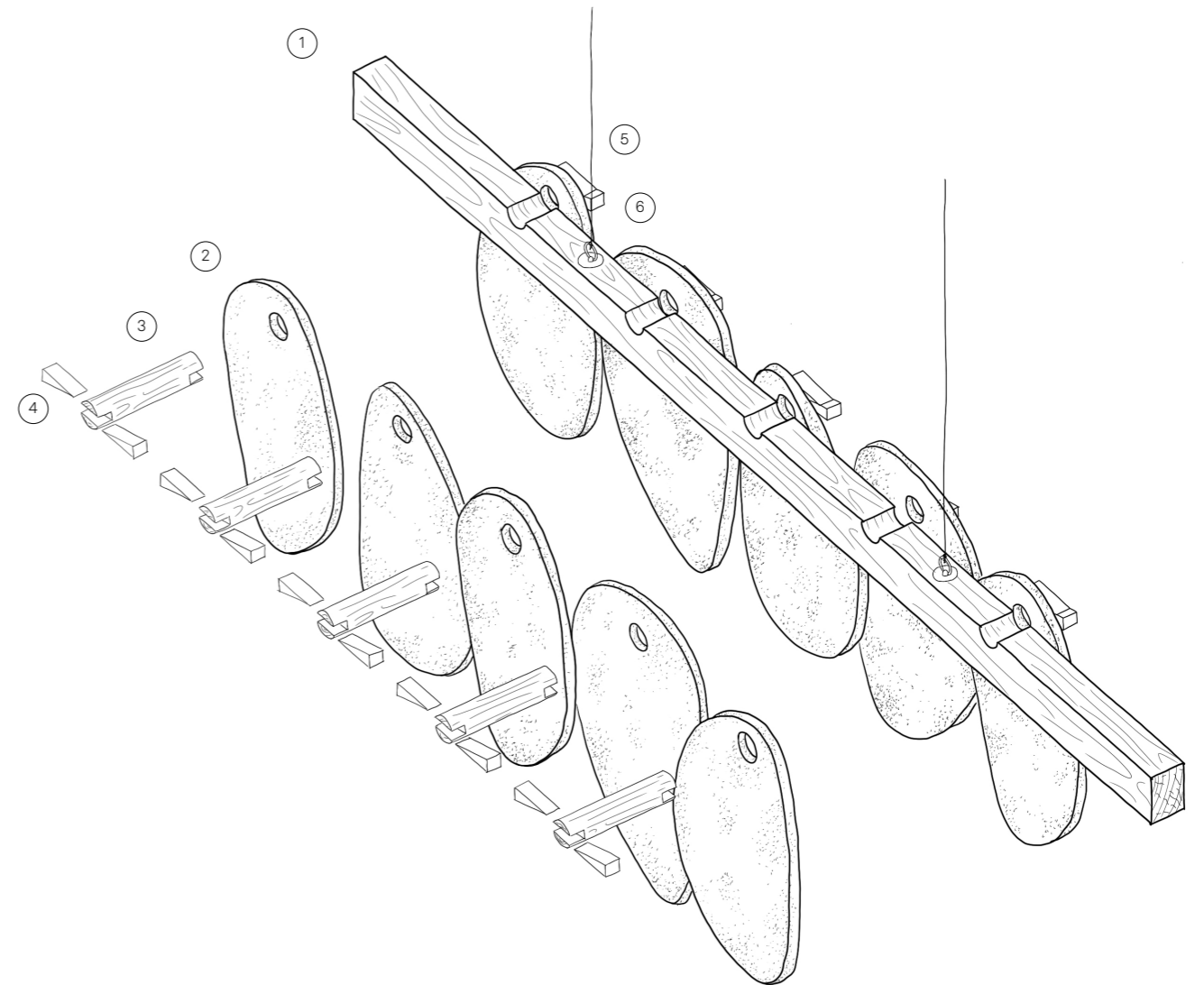



LUM002 Pampille Pendant Light version, displayed above MOB002 La Cabeç
Photo : Cécile Bortoletti ©



LUM002 Pampille Pendant Light, detail
Photo : Cécile Bortoletti ©



LUM002 Pampille Pendant Light, detail
Photo : Cécile Bortoletti ©



LUM002 Pampille Pendant Light version, mounting process
Photo : Cécile Bortoletti ©



LUM002 Pampille Pendant Light, Exhibition Shot at Collectible Brussels
Photo : Cécile Rosenstrauch©

DOSSIER DE COLLECTION

LUM003 . PAMPILLES

Wall sconce

Hand-glazed chamotted black clay, naturally stained ash wood, patinated brass
Custom finishes available upon request according to the La Taulo e l'Oustau collection color palette

LED 2700k

H400xL250xP80mm
Indicative dimensions due to the unique appearance of the clay droplets.

Open collection
Signed certificate of authenticity

Lead time: 8-10 weeks

2024

Glazed chamotted clay plate - Approximately 400x200x10mm	①
Glazed PRNF clay with transparent glaze, sponged finish	
Light Source	②
LED 2700k, Patinated brass mounting	
Wooden keys.	③
Sanded raw oak wood - Naturally Stained Securing the clay plates.	
Wood structure holding the clay plate	④
Naturally stained Oak wood	

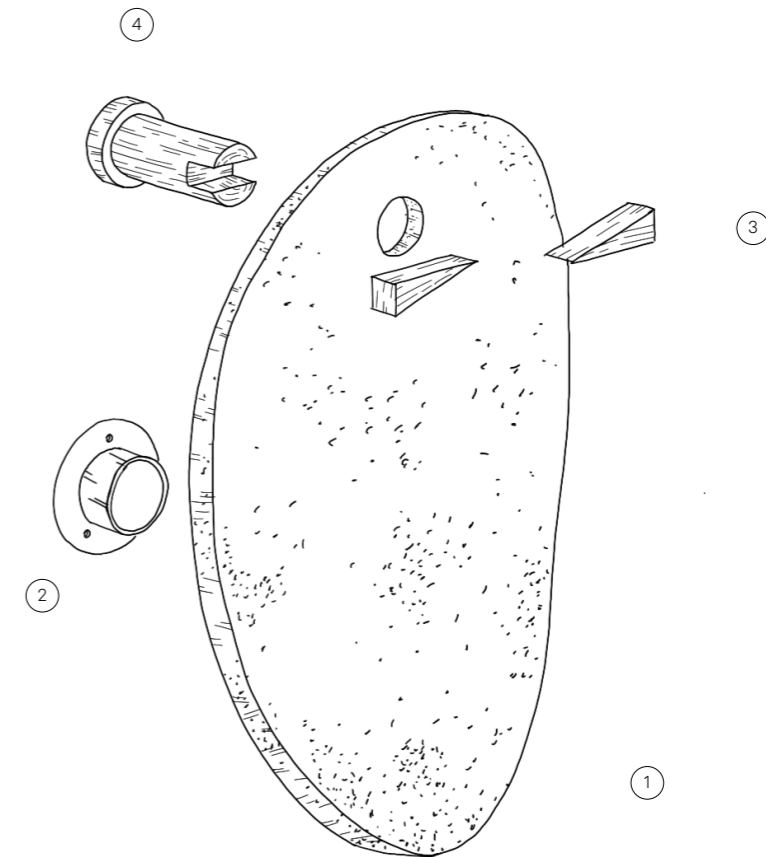



LUM003 Pampille Wall Sconce version
Photo : Geste.s ©



LUM003 Pampille Wall Sconce version, detail
Photo : Geste.s ©



LUM003 Pampille Wall Sconce version
Photo : Geste.s ©



LUM003 Pampille Wall Sconce version
Photo : Geste.s ©



LUM003 Pampille Wall Sconce, Behind LUM002 Pampille Pendant Light, Exhibition Shot at Collectible Brussels
Photo : Camille Lemonnier ©



Portrait in front of the Taulo e l'Oustau Collection, First exhibited at Collectible Brussels
Photo : Camille Lemonnier ©

T

M

B

THOMAS MORINEAU BARTHELEMY

WWW.GESTE-S.COM

La Taulo e l'Oustau
+33(0)6 88 67 65 25
tmb@geste-s.com

GESTE.S
a.s.d